

Submittal Data Sheet



Job or Customer:

Engineer:

Contractor:

Submitted by: Date

Approved by: Date

Order No: Date

Specification:

**ADDITIONAL CORROSIVE
WASTE PRODUCTS**

ENFIELD™
ELECTROFUSION ACID WASTE SYSTEM

LABLINE®
MECHANICAL JOINT ACID WASTE SYSTEM

PLENUMLINE™
FR-PVDF MECHANICAL JOINT ACID WASTE SYSTEM

NEUTRATANK®
NEUTRALIZATION TANKS

Encase™
PP Double Containment System

IPEX corrosive waste piping system has all the accessories necessary for a truly integrated plumbing system, including adjustable acid-resistant floor drains.

For efficiently managing chemical spills, our Floway™ adjustable polypropylene drain ports are specially designed to feed into IPEX acid waste systems.

Key Advantages of the IPEX Floway™ adjustable polypropylene floor drains include:

- Outlet sizes available from 2" – 6"
- Can be configured with adjustable strainers, and plain end or threaded outlets
- Adjustable height feature allows for easy leveling after pouring the finished floors

product availability

Adjustable floor drain

Adjustable acid waste cleanout with nickel-bronze cover

Adjustable height

FLOWAY™ POLYPROPYLENE DRAIN DIMENSIONS – ADJUSTABLE

SPECIFICATION: Floway series F1000 polypropylene adjustable floor drain with 6" diameter strainer and plain end outlet. Body with 14-1/2" diameter flange, and non-puncturing style flashing collar with weep holes.

SERIES F1000 ADJUSTABLE FLOOR DRAIN

Cat. No.	Outlet Size (in)	A (in)	Wgt (lbs)
F1201	2*	10-5/8	3.2
	3	7	2.7
F1401P	4	7	2.8
F1601P	6	7	3.1

All drains are minimum 3" diameter.

* For 2" drains, use the appropriate Enfield or Labline reducer.

OPTIONS

- Gas tight plug
- Male iron pipe thread outlet

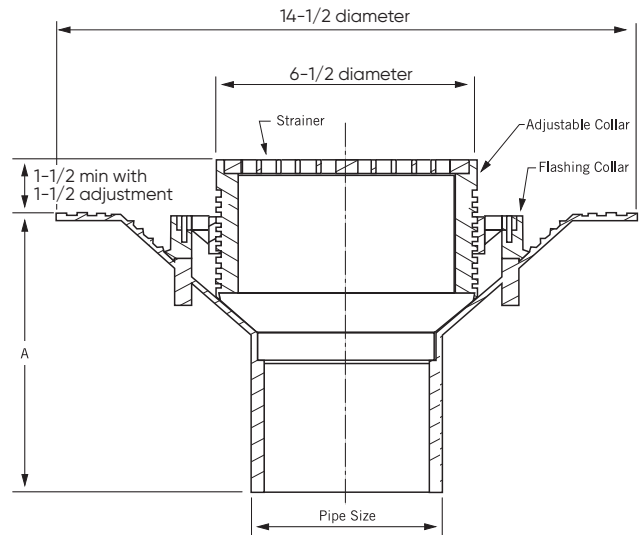

FLOWAY™ POLYPROPYLENE DRAIN OPERATIONAL NOTES

Test	Test Standard	Conditions	Unit	Safe Load
Static Load Test	Adjustable	72°F / full face loading	lbf	2750

The maximum safe live load was calculated by dividing the load at failure by two.

Note:

- i. The press test simulates (under laboratory conditions) the resistance to buckling of floor drains under given loadings and surface area considerations.
- ii. It is not meant to simulate every type of wheel design loading as this will vary according to the equipment supplier.
- iii. The larger the wheel diameter, the more likely it is that the full face loading result can be used as an indication of resistance to load
- iv Polypropylene will normally recover to near its original dimensions after the load is removed.

F1000 Series Adjustable Floor Drain

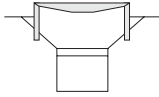

Dimension inches	Significant Number	Product Code
Enfield 2	F1201L	237001
Labline 2	F1201W	237075
3	F1301P	237011
4	F1401P	237021
6	F1601P	237031

Size (inches):

- 2" Enfield
- 3
- 6
- 2" Labline
- 4

Options (select all that apply):

- Gas Tight Plug
- Male Iron Pipe Thread Size Outlet

IPEX Part Number:

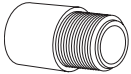
	Dimension inches	Significant Number	Product Code
Gas Tight Plug			
	3	P20036	237815
	4	P20037	237816
	6	P20038	237817
Blank Cover for F Series Drains			
	F1000 Series	P20034	237814
Grid Strainers for F Series Drains			
	F1000 Series	P20013	237807
Male Iron Pipe Threaded Outlet			
	3	-	257091
	4	-	257092
FPT Tap for Priming Drain Assembly			
	3/8	-	237430
	1/2	-	237429
Trap Primer 12" Length w/ 1/2" FPT			
	2	-	257126
	3	-	257127
	4	-	257128

About IPEX by Aliaxis

As leading suppliers of thermoplastic piping systems, IPEX by Aliaxis provides our customers with some of the world's largest and most comprehensive product lines. All IPEX by Aliaxis products are backed by more than 50 years of experience. With state-of-the-art manufacturing facilities and distribution centers across North America, we have established a reputation for product innovation, quality, end-user focus and performance.

Markets served by IPEX by Aliaxis products are:

- Electrical systems
- Telecommunications and utility piping systems
- Industrial process piping systems
- Municipal pressure and gravity piping systems
- Plumbing and mechanical piping systems
- Electrofusion systems for gas and water
- Industrial, plumbing and electrical cements
- Irrigation systems
- PVC, CPVC, PP, PVDF, PE, ABS, and PEX pipe and fittings

Products are supplied and distributed in the United States by IPEX USA LLC.

FlowwayTM, EnfieldTM, Labline[®], PlenumlineTM, Neutratan[®] and EncaseTM are trademarks of IPEX Branding Inc.

This literature is published in good faith and is believed to be reliable. However, it does not represent and/or warrant in any manner the information and suggestions contained in this brochure. Data presented is the result of laboratory tests and field experience.

A policy of ongoing product improvement is maintained. This may result in modifications of features and/or specifications without notice.