

VKR SERIES REGULATING BALL VALVES

Product Data Sheet

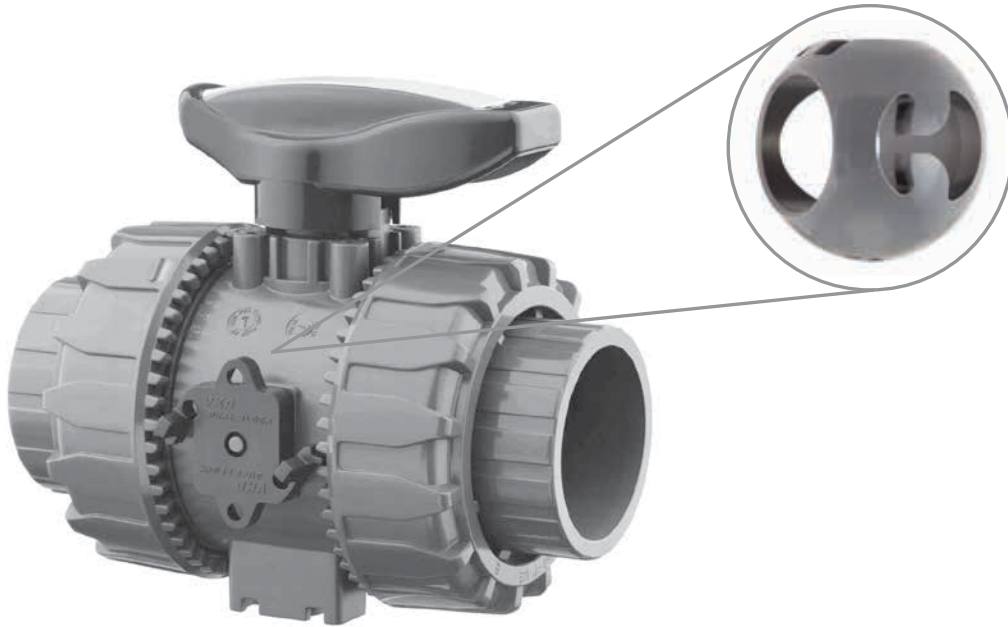

< STANDARDS >



ASTM D1784
ASTM D2464
ASTM D2466
ASTM D2467
ASTM D4101
ASTM D3222
ASTM F1498

Designed to meet the requirements of the most severe industrial applications, IPEX VKR Series Regulating Ball Valves combine the reliability and safety features of IPEX VKD ball valves with a newly designed profiled ball. The patented ball design provides linear flow regulation throughout its full range of operation even when the valve is open just a few degrees. Like a traditional shut-off ball valve, the VKR has a 90° operating angle which allows the use of a standard quarter-turn actuator, ensuring perfect alignment and reducing the torque required for actuation. The patented Dual Block® mechanism locks the union nuts in place preventing back-off during severe service conditions.

VKR Regulating Ball Valves are part of our complete system of IPEX pipe, valves and fittings, engineered and manufactured to our strict quality, performance and dimensional standards.



ANSI B1.20.1

VALVE AVAILABILITY

Body Material	PVC, PP, PVDF
Size Range	1/2" through 2"
Pressure	up to 232 psi
Seats	Teflon® (PTFE)
Seals	EPDM or Fluoropolymer (FPM)
End Connections	Socket (IPS), Threaded (FNPT) Socket (Metric), Flanged (ANSI 150)



Certified to
NSF/ANSI 61 & 372

VKR SERIES REGULATING BALL VALVES

Product Data Sheet

Sample Specifications

1.0 Ball Valves – VKR

1.1 Material

- The valve body, stem, ball and unions shall be made of PVC compound which shall meet or exceed the requirements of cell classification 12454 according to ASTM D1784.
- or The valve body, stem, ball and unions shall be made of stabilized polypropylene (PP) homopolymer compound, also containing a RAL 7032 pigment, which shall meet or exceed the requirements of Type PP according to ASTM D4101.
- or The valve body, including end connectors and unions shall be made of virgin, non-regrind polyvinylidene fluoride (PVDF) compound which shall meet or exceed the requirements of Table 1 according to ASTM D3222.

1.2 Seats

- The ball seats shall be made of Teflon® (PTFE).

1.3 Seals

- The o-ring seals shall be made of EPDM.
- or The o-ring seals shall be FPM.

2.0 Connections

2.1 Socket style

- The IPS socket PVC end connectors shall conform to the dimensional standards ASTM D2466 and ASTM D2467.
- or The Metric socket PP end connectors shall conform to the dimensional standard ISO 11922-1.
- or The Metric socket PVDF end connectors shall conform to the dimensional standard ISO 10931.

2.2 Threaded style

- The female NPT threaded PVC end connectors shall conform to the dimensional standards ASTM D2464, ASTM F1498, and ANSI B1.20.1.
- or The female NPT threaded PP end connectors shall conform to the dimensional standards ASTM F1498, and ANSI B1.20.1.

3.0 Design Features

- The valve shall be double blocking with union ends.
- All valves shall have a flow indication arrow on the side of the body.
- The valve body shall be single end entry with a threaded carrier (ball seat support).

- The threaded carrier shall be adjustable with the valve installed.
- The valve body shall have an expansion and contraction compensating groove on the molded end.
- The valve body, union nuts, and carrier shall have deep square style threads for increased strength.
- The ball design shall allow flow regulation starting at a 60 angle of opening.
- The ball and stem shall be machined smooth to minimize wear on valve seats and seals.
- The stem design shall feature double o-ring seals as well as a safety shear point above the o-rings.
- All valve seats shall have o-ring backing cushions to compensate for wear and prevent seizure of the ball.
- All valves shall have integrally molded mounting features for actuation.
- All valves shall have integrally molded support bracketing for anchoring.

3.1 Pressure Tested

- All valves shall have been pressure tested in both the open and closed positions by the manufacturer.

3.2 Pressure Rating

- All PVC and PVDF valves shall be rated at 232 PSI at 73°F.
- All PP valves shall be rated at 150 PSI at 73°F.
- All flanged valves shall be rated at 150 PSI at 73°F.

3.3 Markings

- All valves shall be marked to indicate size, material designation, and manufacturers name or trade mark.

3.4 Color Coding

- All PVC valves shall be color-coded dark gray.
- or All PP valves shall be color-coded beige gray.
- or All PVDF valves shall not be color-coded and be white (unpigmented) in appearance.

4.0 NSF Listings

- All PVC valves shall be listed with NSF to standard 61 for potable water.
- All PVC valves shall be listed with NSF to Standard 372 for lead content requirements.

- All valves shall be Xirtec® PVC, PP or PVDF by IPEX or approved equal.

VKR SERIES REGULATING BALL VALVES

Product Data Sheet

Valve Selection

Valve Size (inches)	Body Material	O-ring Material	IPEX Part Number IPS Socket	Pressure Rating at 73°F
1/2	PVC	EPDM	353684	232 psi
		FPM	353675	
3/4	PVC	EPDM	353683	
		FPM	353676	
1	PVC	EPDM	353682	
		FPM	353678	
1-1/4	PVC	EPDM	353681	
		FPM	353685	
1-1/2	PVC	EPDM	353680	
		FPM	353686	
2	PVC	EPDM	353679	
		FPM	353677	

Body Material:

- PVC
- PP
- PVDF

Size:

- 1/2"
- 3/4"
- 1"
- 1-1/4"
- 1-1/2"
- 2"

Seals:

- EPDM
- FPM

IPEX Part Number:

Dimensions

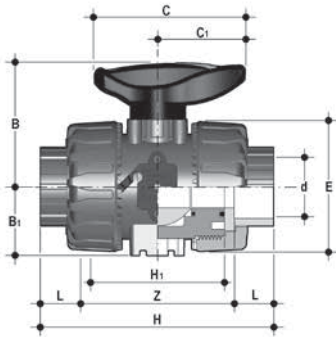

IPS Socket Connections – Dimension (inches)

Size	d	H	L	Z	H ₁	E	B ₁	B	C ₁	C
1/2	0.84	4.61	0.89	2.83	2.56	2.13	1.14	2.13	1.57	2.64
3/4	1.05	5.08	1.00	3.07	2.76	2.56	1.36	2.56	1.93	3.35
1	1.32	5.59	1.13	3.33	3.07	2.87	1.54	2.74	1.93	3.35
1-1/4	1.66	6.38	1.26	3.86	3.46	3.39	1.81	3.25	2.52	4.25
1-1/2	1.90	6.77	1.38	4.02	3.66	3.86	2.05	3.50	2.52	4.25
2	2.38	7.83	1.50	4.83	4.37	4.80	2.44	4.25	2.99	5.28

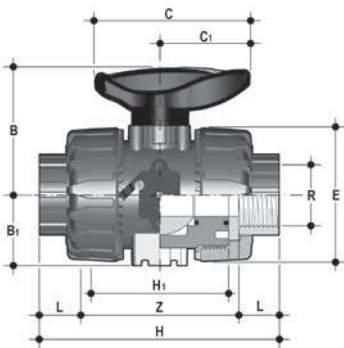

Female NPT Threaded Connections – Dimension (inches)

Size	R	H	L	Z	H ₁	E	B ₁	B	C ₁	C
1/2	1/2-NPT	4.37	0.70	2.97	2.56	2.13	1.14	2.13	1.57	2.64
3/4	3/4-NPT	4.61	0.71	3.19	2.76	2.56	1.36	2.56	1.93	3.35
1	1-NPT	5.31	0.89	3.54	3.07	2.87	1.54	2.74	1.93	3.35
1-1/4	1-1/4-NPT	6.02	0.99	4.05	3.46	3.39	1.81	3.25	2.52	4.25
1-1/2	1-1/2-NPT	6.14	0.97	4.20	3.66	3.86	2.05	3.50	2.52	4.25
2	2-NPT	7.32	1.17	4.99	4.37	4.80	2.44	4.25	2.99	5.28

VKR SERIES REGULATING BALL VALVES

Product Data Sheet

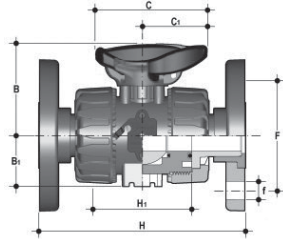

VKD Flanged Connections – Dimension (inches)

Size	H	H ₁	B	B ₁	C	C ₁	F	f	U
1/2"	5.63	2.56	2.13	1.14	2.64	1.58	2.37	0.63	0.16
3/4"	6.77	2.76	2.56	1.36	3.35	1.93	2.75	0.63	0.16
1"	7.36	3.07	2.74	1.54	3.35	1.93	3.13	0.63	0.16
1-1/4"	7.48	3.47	3.25	1.81	4.25	2.52	3.5	0.63	0.16
1-1/2"	8.35	3.66	3.5	2.05	4.25	2.52	3.87	0.63	0.16
2"	9.21	4.37	4.25	2.44	5.28	2.99	4.75	0.75	0.16

Note: Dimensions based on VKD ANSI 150 Flanging Kit

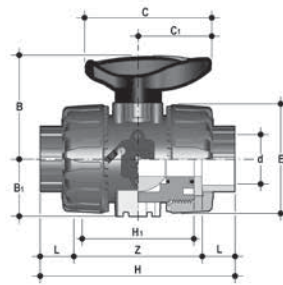

Metric Socket Connections – Dimension (inches)

Size	d	H	L	Z	H ₁	E	B ₁	B	C ₁	C
20mm	0.79	4.02	0.57	2.87	2.56	2.13	1.14	2.13	1.57	2.64
25mm	0.98	4.49	0.63	3.23	2.76	2.56	1.36	2.56	1.93	3.35
32mm	1.26	4.96	0.71	3.54	3.07	2.87	1.54	2.74	1.93	3.35
40mm	1.57	5.55	0.81	3.94	3.35	3.39	1.81	3.25	2.52	4.25
50mm	1.97	6.46	0.93	4.61	3.66	3.86	2.05	3.50	2.52	4.25
63mm	2.48	7.83	1.08	5.67	4.37	4.80	2.44	4.25	2.99	5.28

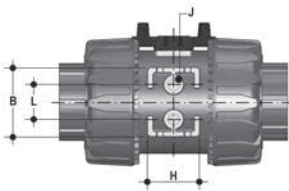

Support Bracket – Dimension (inches)

Size	J	B	L	H
1/2	M4	1.24	0.79	1.06
3/4	M4	1.57	0.79	1.18
1	M4	1.57	0.79	1.18
1-1/4	M6	1.97	1.18	1.38
1-1/2	M6	1.97	1.18	1.38
2	M6	2.36	1.18	1.57

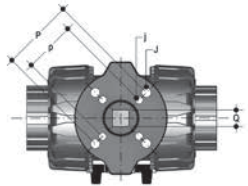

Actuation Pad – Dimension (inches)

Size	B ₂	p	P	j	J	T	Q
1/2	2.28	F03	F04	0.22	0.22	0.47	0.43
3/4	2.89	F03	F05	0.22	0.26	0.47	0.43
* 3/4	2.89	F04		0.22		0.47	0.43
1	2.91	F03	F05	0.22	0.26	0.47	0.43
* 1	2.91	F04		0.22		0.43	0.43
1-1/4	3.82	F05	F07	0.26	0.33	0.63	0.55
1-1/2	4.09	F05	F07	0.26	0.33	0.63	0.55
2	4.49	F05	F07	0.26	0.33	0.63	0.55

*Available upon request.

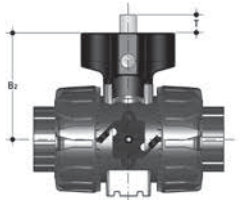

Weights

Approximate Weight (lbs)

Size (inches)		IPS / Metric Socket			FNPT Threaded	
IPS	Metric	PVC	PP	PVDF	PVC	PP
1/2	20mm	0.47	0.32	0.60	0.46	0.31
3/4	25mm	0.76	0.48	0.98	0.74	0.50
1	32mm	0.99	0.66	1.29	0.99	0.67
1-1/4	40mm	1.58	1.06	2.07	1.49	1.01
1-1/2	50mm	2.15	1.50	2.74	2.11	1.43
2	63mm	3.77	2.57	4.82	3.68	2.50

VKR SERIES REGULATING BALL VALVES

Product Data Sheet

Pressure – Temperature Ratings

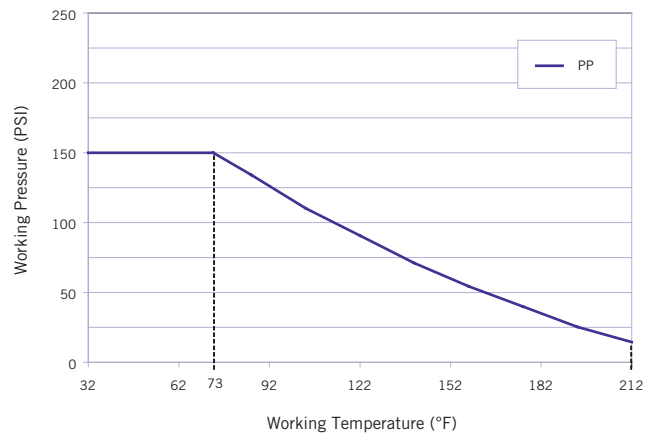
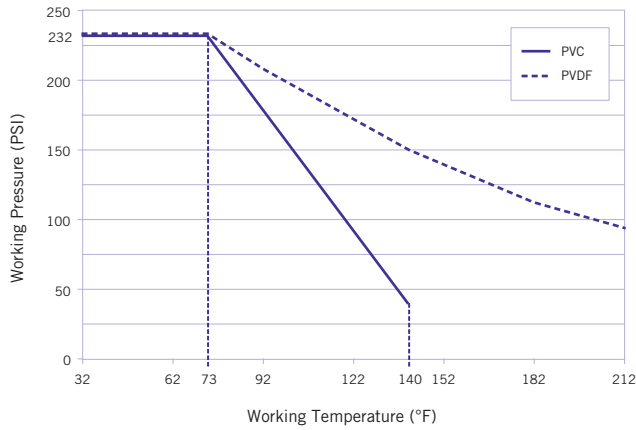

Flow Performance Curve

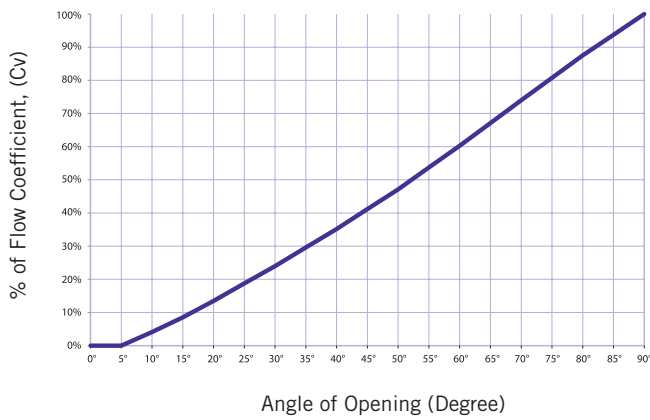

Pressure Loss Chart

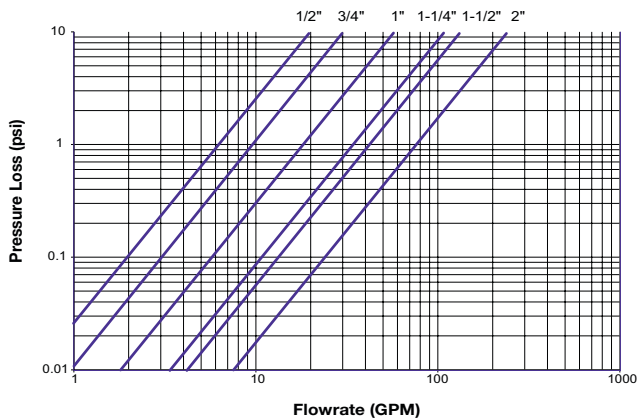

Flow Coefficients

Size (in)	C _v
1/2	6.1
3/4	9.4
1	17.8
1-1/4	33.2
1-1/2	41.1
2	74.1

VKR SERIES REGULATING BALL VALVES

Product Data Sheet

Components

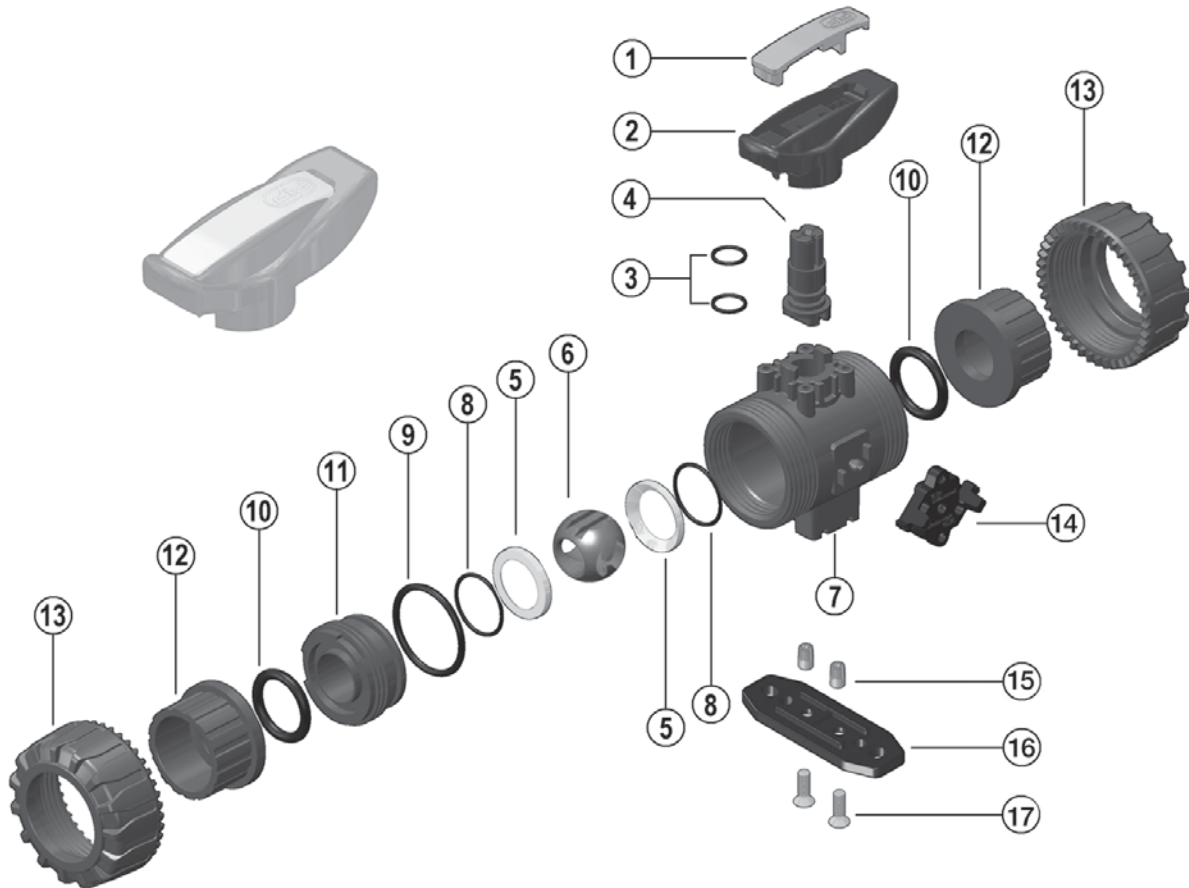

#	Component	Material	Qty
1	insert	PVC / PP / PVDF	1
2	handle	PVC / PP / PVDF	1
3	stem o-ring	EPDM / FPM	2
4	stem	PVC / PP / PVDF	1
5	ball seat	PTFE	2
6	profiled ball	PVC / PP / PVDF	1
7	body	PVC / PP / PVDF	1
8	ball seat o-ring	EPDM / FPM	2
9	body o-ring	EPDM / FPM	1
10	socket o-ring	EPDM / FPM	2

#	Component	Material	Qty
11	carrier with stop ring	PVC / PP / PVDF	1
12	end connector	PVC / PP / PVDF	2
13	union nut	PVC / PP / PVDF	2
14	DUAL BLOCK®	POM	1
* 15	bracket bushing	SS / brass	2
* 16	mounting plate	GRPP	1
* 17	screw	SS	2

* Optional Accessories

VKR SERIES REGULATING BALL VALVES

Product Data Sheet

Installation Procedures

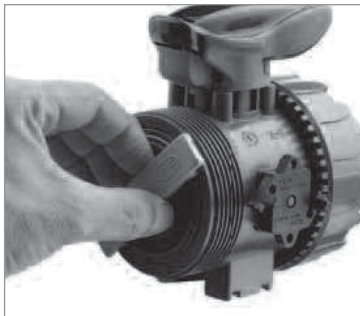
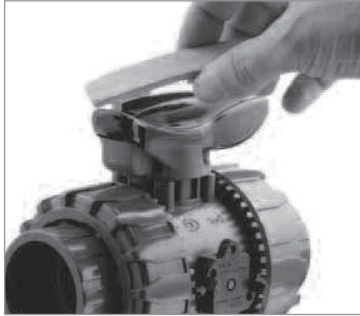

1. Remove the union nuts (part #13 on previous pages) and slide them onto the pipe.
2. Please refer to the appropriate connection style sub-section:
 - a. For socket style, solvent cement or fuse the end connectors (12) onto the pipe ends. For correct solvent cementing procedure, please refer to the section entitled, "Joining Methods – Solvent Cementing" in the IPEX Industrial Technical Manual Series, "Volume I: Vinyl Process Piping Systems". Be sure to allow sufficient cure time before continuing with the valve installation.
 - b. For threaded style, thread the end connectors (12) onto the pipe ends. For correct joining procedure, please refer to the section entitled, "Joining Methods – Threading" in the IPEX Industrial Technical Manual Series, "Volume I: Vinyl Process Piping Systems".
3. Open and close the valve to ensure that the carrier (11) is at the desired adjustment. If adjustment is required, ensure that the valve is in the closed position then remove the insert tool (1) from the handle (2).
4. Ensure that the valve is in the closed position, and that the socket o-rings (10) are properly fitted in their grooves. If anchoring is required, insert the bracket bushings (15) into the bottom of the valve. Carefully place the valve in the system between the two end connections and fix if necessary.
5. Tighten the union nut on the side opposite to that which is marked "ADJUST". Hand tightening is typically sufficient to maintain a seal for the maximum working pressure. Over-tightening may damage the threads on the valve body and/or the union nut, and may even cause the union nut to crack.
6. Tighten the union nut on the side marked "ADJUST". Tightening the union nuts in this order results in the best possible valve performance due to optimum positioning and sealing of the ball and seat support system.
7. Open and close the valve to again ensure that the cycling performance is adequate. If adjustment is required, place the valve in the closed position, loosen the union nuts, remove the valve from the system, and then continue from Step 3.
8. Engage the Dual Block® system by affixing the molded piece (14) to the side of the valve body. This feature will prevent back-off of the union nuts during operation.

VKR SERIES REGULATING BALL VALVES

Product Data Sheet

Disassembly



1. If removing the valve from an operating system, isolate the valve from the rest of the line. Be sure to depressurize and drain the valve and isolated branch.
2. If necessary, detach the valve from the support structure by disassembling the connections to the optional bracket on the bottom of the valve body (7).
3. Unlock the Dual Block® system by compressing the two ends of the molded piece (14) to the unlocked position. Loosen both union nuts (13) and drop the valve out of the line. If retaining the socket o-rings (10), take care that they are not lost when removing the valve from the line.
4. Place the valve in the open position then line up the moldings on the wrench tool (1) with the slots in the carrier (found on the side marked "ADJUST"). Loosen and remove the carrier (11).
5. Carefully press the ball (6) out of the valve body, taking care not to score or damage the outer surface.
6. Remove the handle (2) by pulling upwards.
7. Press the stem (4) into the valve body from above.
8. The stem o-rings (3), body o-ring (9), ball seats (5), and ball seat o-rings (8) can now be removed and/or replaced.

Note: It is not typically necessary to disassemble the Dual Block® components.

Assembly

Note: Before assembling the valve components, it is advisable to lubricate the o-rings with a water soluble lubricant. **Be sure to consult the "IPEX Chemical Resistance Guide" and/or other trusted resources to determine specific lubricant-rubber compatibilities.**

1. Replace the stem o-rings (3), body o-ring (9), ball seat o-rings (8), and ball seats (5) in their proper positions.
2. Insert the stem (4) into position from inside the valve body (7).
3. Replace the handle (2) as shown.
4. Carefully insert the ball (6) into the valve body as shown, taking care not to score or damage the outer surface. Ensure that the valve handle and ball position correspond to the same operating position.
5. Insert the threaded carrier (11) and tighten into the valve body. Use the wrench tool to sufficiently tighten.
6. Place the end connectors (12) into the union nuts (13), then thread onto the valve body taking care that the socket o-rings remain properly fitted in their grooves.
7. Engage the Dual Block® system by affixing the molded piece (16) to the side of the valve body.



VKR SERIES REGULATING BALL VALVES

Product Data Sheet

Testing and Operating

The purpose of system testing is to assess the quality of all joints and fittings to ensure that they will withstand the design working pressure, plus a safety margin, without loss of pressure or fluid. Typically, the system will be tested and assessed in sub-sections as this allows for improved isolation and remediation of potential problems. With this in mind, the testing of a specific installed valve is achieved while carrying out a test of the overall system.

An onsite pressure test procedure is outlined in the IPEX Industrial Technical Manual Series, "Volume I: Vinyl Process Piping Systems" under the section entitled, "Testing". The use of this procedure should be sufficient to assess the quality of a valve installation. **In any test or operating condition, it is important to never exceed the pressure rating of the lowest rated appurtenance in the system.**

Important points:

- Never test thermoplastic piping systems with compressed air or other gases including air-over-water boosters.
- When testing, do not exceed the rated maximum operating pressure of the valve.
- Avoid the rapid closure of valves to eliminate the possibility of water hammer which may cause damage to the pipeline or the valve.

For safety reasons, please contact IPEX customer service and technical support when using volatile liquids such as hydrogen peroxide (H₂O₂) and sodium hypochlorite (NaClO). These liquids may vaporize causing a potentially dangerous pressure increase in the dead space between the ball and the valve body. Special VKR ball valves are available for these types of critical applications.

Please contact IPEX customer service and technical support with regard to any concern not addressed in this data sheet or the technical manual.

About IPEX by Aliaxis

As leading suppliers of thermoplastic piping systems, IPEX by Aliaxis provides our customers with some of the world's largest and most comprehensive product lines. All IPEX by Aliaxis products are backed by more than 50 years of experience. With state-of-the-art manufacturing facilities and distribution centers across North America, we have established a reputation for product innovation, quality, end-user focus and performance.

Markets served by IPEX by Aliaxis products are:

- Electrical systems
- Telecommunications and utility piping systems
- Industrial process piping systems
- Municipal pressure and gravity piping systems
- Plumbing and mechanical piping systems
- Electrofusion systems for gas and water
- Industrial, plumbing and electrical cements
- Irrigation systems
- PVC, CPVC, PP, PVDF, PE, ABS, and PEX pipe and fittings

Xirtec® is a registered trademark used under license.

This literature is published in good faith and is believed to be reliable. However, it does not represent and/or warrant in any manner the information and suggestions contained in this brochure. Data presented is the result of laboratory tests and field experience.

A policy of ongoing product improvement is maintained. This may result in modifications of features and/or specifications without notice.