

VOLUME VI: DOUBLE CONTAINMENT PIPING SYSTEMS

Industrial Technical
Manual Series



N I N T H E D I T I O N

DOUBLE CONTAINMENT PIPING SYSTEMS

Encase™ polypropylene piping

Guardian™ systems

Clear-Guard™ and CustomGuard® systems

Centra-Guard™ low-point leak detection



IPEX
by aliaxis

Double Containment Piping Systems

Industrial Technical Manual Series

Vol. VI, 9th Edition

© 2023 by IPEX. All rights reserved. No part of this book may be used or reproduced in any manner whatsoever without prior written permission. For information contact: IPEX, Marketing, 1425 North Service Rd. East, Unit 3, Oakville, Ontario, L5J 4C7.

The information contained here within is based on current information and product design at the time of publication and is subject to change without notification. IPEX does not guarantee or warranty the accuracy, suitability for particular applications, or results to be obtained therefrom.

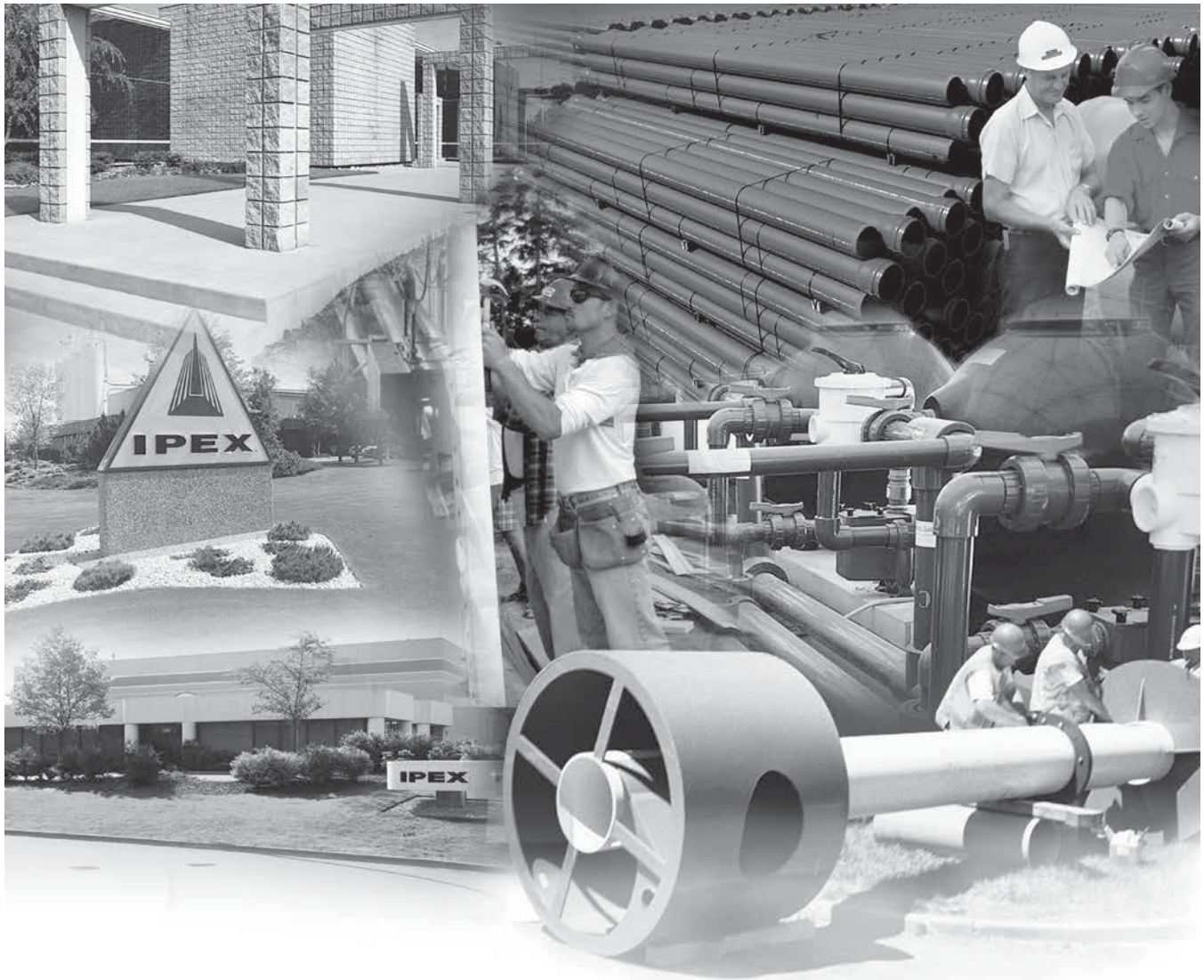

About IPEX

At IPEX, we have been manufacturing non-metallic pipe and fittings since 1951. We formulate our own compounds and maintain strict quality control during production. Our products are made available for customers thanks to a network of regional stocking locations throughout North America. We offer a wide variety of systems including complete lines of piping, fittings, valves and custom-fabricated items.

More importantly, we are committed to meeting our customers' needs. As a leader in the plastic piping industry, IPEX continually develops new products, modernizes manufacturing facilities and acquires innovative process technology. In addition, our staff take pride in their work, making available to customers their extensive thermoplastic knowledge and field experience. IPEX personnel are committed to improving the safety, reliability and performance of thermoplastic materials. We are involved in several standards committees and are members of and/or comply with the organizations listed on this page.

For specific details about any IPEX product, contact our customer service department.



Safety Alerts

Engineered thermoplastics are safe inert materials that do not pose any significant safety or environmental hazards during handling or installation. However, improper installation or use can result in personal injury and/or property damage. It is important to be aware of and recognize safety alert messages as they appear in this manual.

The types of safety alert messages are described below.



This safety alert symbol indicates important safety messages in this manual. When you see this symbol be alert to the possibility of personal injury and carefully read and fully understand the message that follows.

WARNING

“WARNING” identifies hazards or unsafe practices that can result in severe personal injury or death if instructions, including recommended precautions, are not followed.

CAUTION

“CAUTION” identifies hazards or unsafe practices that can result in minor personal injury or product or property damage if instructions, including recommended precautions, are not followed.

NOTE: The use of the word “NOTE” signifies special instructions which are important but are not related to hazards.

For the materials described in this manual, the following warning applies.

WARNING

- **NEVER** use compressed air or gas in PVC/CPVC/PP/PVDF pipe and fittings.
- **NEVER** test PVC/CPVC/PP/PVDF pipe and fittings with compressed air or gas, or air-over-water boosters.
- **ONLY** use PVC/CPVC/PP/PVDF pipe for water and approved chemicals.

Use of compressed air or gas in PVC/CPVC/PP/PVDF pipe and fittings can result in explosive failures and cause severe injury or death.



NOTES

Contents

	Safety Alerts	i
Section One:	General Information	1
	Overview	1
Section Two:	Encase™	3
	Overview	3
	Dimensions	4
	Installation Procedures	9
	Handling and Storage	10
	Encase™ Fusion Instructions	11
	Pipe Modifications	16
	Pipe Termination Fittings	16
	Fault Code Analysis	17
	Machine Repair Information	19
	Cold Weather Fusion	19
	Testing	20
	Pipe Repair	22
Section Three:	Guardian™ & Clear-Guard™	25
	Guardian™ & Clear-Guard™ Overview	25
	Guardian™ & Clear-Guard™ Dimensions	26
	Guardian™ & Clear-Guard™ Installation Procedures	28
	Handling and Storage	29
	Solvent Welding Instructions for PVC & CPVC Pipe & Fittings	30
	Closure Couplings	38
	Termination Fittings	41
	Testing	42
	Pipe Repair	44
Section Four:	CustomGuard®	45
	Overview	45
	Dimensions	46
	Installation Procedures	53
	Testing	57

Section Five:	Leak Detection	59
	Centra-Guard™ Electronic Low-Point Leak Detection.	59
	Guardian™ PAL-AT Cable Leak Detection.	65
	Portable Leak Detection Sensor	68
Section Six:	Valves	69
Section Seven:	System Design	71
	External Support.	71
	Expansion Loops, Elbows, and Joints.	72
	Installation of Buried Pipes	75
	Installation Considerations	78
Section Eight:	Specifications	81
	Encase™	81
	Guardian™.	82
	CustomGuard®.	84
	Guardian PAL-AT Continuous Cable Leak Detection	94
Appendix A:	Conversion Charts	95
	Double Containment Material Recommendation Checklist	95
	Project Start-Up Checklist.	100

SECTION ONE: GENERAL INFORMATION

Overview

Safety and environmental issues, such as ground water contamination, have long been serious concerns for North American industry. Add to this the enormous costs of litigation, clean up, and increasingly stringent corporate guidelines and legal regulations, and the importance of fail-safe double containment systems becomes immediately clear.

However, exactly what constitutes 'double containment'? Although, on paper, simple solutions such as the lining of ditches or similar methods may appear to meet double containment requirements, in reality, they fall short. With double containment, engineers are not designing a single system or even two separate single-wall systems, but rather a combination of the two: interrelated systems, where changing conditions continually affect both carrier and containment pipes (also referred to as primary and secondary pipes).

IPEX's Experience

By investing heavily in people and technology, IPEX has amassed more than 30 years of expertise in design and fabrication of double containment systems. In addition, IPEX is the only manufacturer of double containment systems offering all of the following:

- A specialized and dedicated division dealing exclusively with double containment.
- The ability to manufacture a large majority of double containment components in-house.
- A variety of materials including thermoplastics, thermosets, and metallic and dissimilar systems.
- Both drainage and pressure systems.
- A patented system with 60% fewer joints than conventional systems.
- Both off-the-shelf and custom-designed systems.
- Continuous cable as well as low point-of-collection leak detection systems.

Double Containment Systems

With such breadth and depth of products, IPEX offers customers proven designs that best suit their needs. Because of the large variety of systems available, it would be difficult to include all of them in one publication. Therefore, this manual deals specifically with those systems most commonly used, including:

- **Encase™**, a polypropylene piping system that uses proven Enfusion joining methods to provide an easy-to-install, safe, reliable, and cost-effective method to convey chemical waste under gravity-flow conditions.
- **Guardian™ systems**. Made from Xirtec® PVC and Xirtec® CPVC, these systems offer a complete selection of pre-tested modular components that are considered unmatched in the industry. Installed using its patented Centra-Lok™ design, Guardian reduces the number of joints in a system by as much as 60%.
- **Clear-Guard™** is a fail-safe, fully pressure-rated clear containment system which allows for easy detection of leaks and eliminates the risks associated with piping aggressive chemicals overhead. Clear-Guard utilizes Guardian's patented Centra-Lok fitting design, which reduces the required joints by 40-60% containment. Fittings are available in clear or "cost-saving" opaque.
- **CustomGuard® systems**. Together with Encase and Guardian, CustomGuard sets IPEX apart from any other double containment system. CustomGuard is available in several different materials including carbon and stainless steel, copper, fiberglass, plastics, and dissimilar materials. Unlike other manufacturers, IPEX is not constrained by a limited material selection. This variety enables IPEX to provide customers with the best solution for their double containment needs.
- **Centra-Guard™**, a low-point electronic leak detection system that offers an economical proactive solution against potential containment challenges. Its automated, trouble-free, and user-friendly design guards against environmental damage and the high cost of cleanup.

Please contact your IPEX representative for details on all other systems not included in this manual.

NOTES

SECTION TWO: ENCASE™

Overview

Introduction

Encase is a polypropylene piping system that uses proven Enfusion joining methods to provide an easy-to-install, safe, reliable, and cost-effective method to carry chemical waste under gravity-flow conditions. Proven by over thirty years of success, our electrofusion-joint system is the preferred solution for virtually all underground and critical area chemical waste applications.

At the heart of our patented Encase polypropylene system is its electrofusion fitting with a heavy-gauge resistance wire molded into the socket. The result is a premier system that offers a considerable reduction in installation time and the highest quality leak-free joints. Pipe and fittings are made from non/flame retardant polypropylene. The material used in the manufacturing of Encase pipe and fittings complies with the material requirements of ASTM D4101 Standard Specification for Polypropylene Injection and Extrusion Materials.

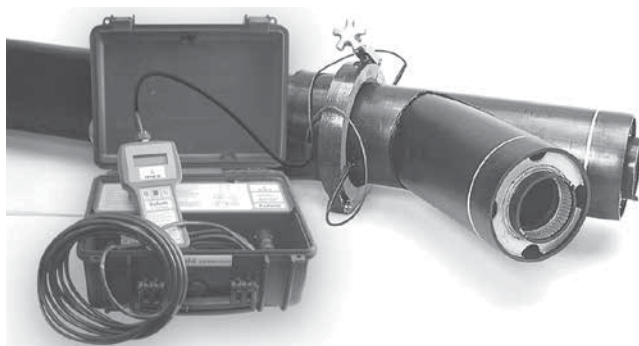

ENCASE



Design

Encase is manufactured in both flame (FRPP) and non-flame retardant polypropylene (NFRPP). The same material inside and out combined with expansion anchor plates on each fitting eliminates the need for expansion loops and extra design considerations.

Encase is designed in modular form to allow contractors to take stock items and assemble them with minimal site fabrication. Where a contractor requires a pre-assembled manifold, these can be provided by IPEX upon receipt of dimensional drawings. This type of custom fabrication can be provided in lengths up to 40 feet.

All pipes and fittings have a socket welded into position on the upstream side of the component and a spigot on the downstream side. After fusing the carrier joint, a secondary coupling is used to close the containment sections together.

Encase™ Dimensions

Pipe – Schedule 40, Socket x Spigot

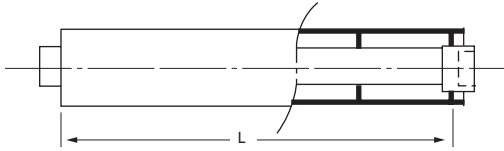

Carrier/Containment (in.)	Part No.	Carrier / Containment L (ft)
1-1/2 / 4	246040	20 + 1-1/4" / 20
2 / 4	246050	20 + 1-9/16" / 20
3 / 6	246060	20 + 1-7/8" / 20
4 / 8	246070	20 + 2" / 20
6 / 10	246020	20 + 2-1/2" / 20
8 / 12	246030	20

Secondary Coupling – Socket

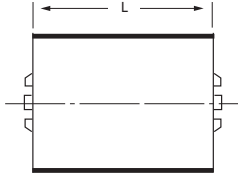

Size (in.)	Part No.	L (in.)
4	231114	5-7/8
6	231116	6-1/2
8	231118	6-3/8
10	231110	9
12	231112	10

Secondary Repair Coupling – Socket

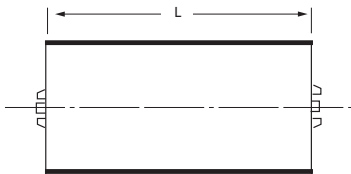

Size (in.)	Part No.	L (in.)
4	231004	8-5/8
6	231006	10-5/8
8	231008	11-1/2
10	231010	11-1/2
12	231009	11-1/2

Encase™ Dimensions

1/4 Bend – Socket x Spigot

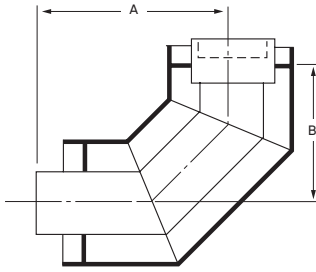

Carrier/ Containment (in.)	Part No.	A (in.)	B (in.)
1-1/2 / 4	231134	12-3/8	11-1/4
2 / 4	231135	12-5/8	11
3 / 6	231136	13-7/8	11-1/8
4 / 8	231137	15-7/8	13-1/4
6 / 10	231132	20-3/8	14-5/8
8 / 12	231133	23	16

1/8 Bend – Socket x Spigot

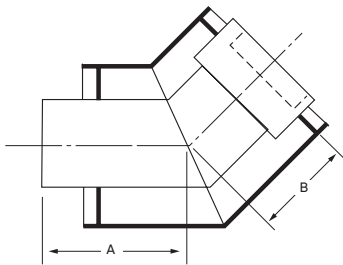

Carrier/ Containment (in.)	Part No.	A (in.)	B (in.)
1-1/2 / 4	231141	8	6-7/8
2 / 4	231142	8-1/4	6-5/8
3 / 6	231143	9-1/8	6-3/8
4 / 8	231144	10-1/8	7-1/2
6 / 10	231139	13-7/8	8
8 / 12	231140	15-1/2	8-3/8

Equal Wye – Socket x Spigot x Socket

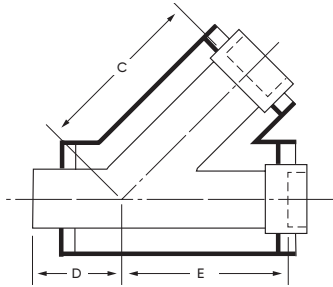

Carrier/ Containment (in.)	Part No.	C (in.)	D (in.)	E (in.)
1-1/2 / 4	231153	9	8-1/8	9
2 / 4	231154	8-3/4	8-3/8	8-3/4
3 / 6	231155	13	9-1/8	13
4 / 8	231156	16-1/8	10-1/4	16-1/8
6 / 10	231151	18-3/4	13-7/8	18-3/4
8 / 12	231152	21-1/8	15-1/2	21-1/8

Reducing Wye – Socket x Spigot x Socket

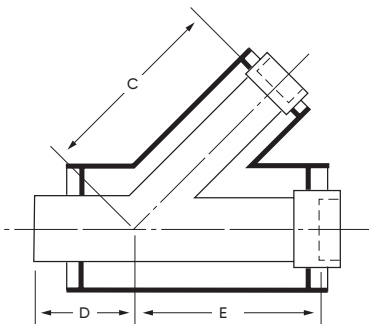

Carrier (in.)	Containment (in.)	Part No.	C (in.)	D (in.)	E (in.)
2 x 1-1/2	4 x 4	231187	9	8-3/8	8-3/4
3 x 1-1/2	6 x 4	231188	12-1/2	7-5/8	11-1/2
3 x 2	6 x 4	231189	12-1/4	7-5/8	11-1/2
4 x 2	8 x 4	231190	13-3/4	7-1/4	13-1/4
4 x 3	8 x 6	231191	14-3/8	8-3/4	14-3/4
6 x 2	10 x 4	231181	14-3/4	9-3/8	14-1/2
6 x 3	10 x 6	231182	16-1/8	10-7/8	15-7/8
6 x 4	10 x 8	231183	17-3/4	12-3/8	17-1/4
8 x 3	12 x 6	231184	17-5/8	12	16-1/8
8 x 4	12 x 8	231185	19-1/2	12-5/8	18-1/4
8 x 6	12 x 10	231186	20-5/8	14-1/8	19-3/4

Encase™ Dimensions

Comb. Wye & 1/8 Bend – Socket x Spigot x Socket

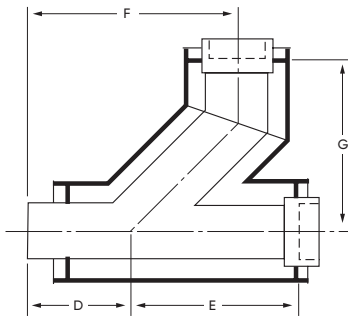

Carrier (in.)	Containment (in.)	Part No.	D (in.)	E (in.)	F (in.)	G (in.)
1-1/2	4	231203	8-1/8	9	15-7/8	12-1/4
2	4	231204	8-3/8	8-3/4	16-1/8	12
3	6	231205	9-1/8	13	19-3/4	17
4	8	231206	10-1/4	16-1/8	22-1/2	20
6	10	231201	13-7/8	18-3/4	26-7/8	22-1/2
8	12	231202	15-1/2	19-1/8	33-5/8	26-1/2

Reducing Comb. Wye & 1/8 Bend – Socket x Spigot x Socket

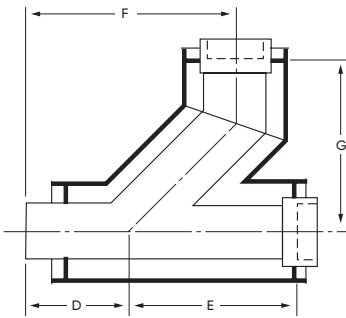

Carrier (in.)	Containment (in.)	Part No.	D (in.)	E (in.)	F (in.)	G (in.)
2 x 1-1/2	4 x 4	231227	8-3/8	8-3/4	13-5/8	12-1/4
3 x 1-1/2	6 x 4	231228	7-5/8	11-1/2	17-1/8	14-1/4
3 x 2	6 x 4	231229	7-5/8	11-1/2	17-3/8	14
4 x 2	8 x 4	231230	7-1/4	13-1/4	16-3/4	15-1/4
4 x 3	8 x 6	231231	8-3/4	14-3/4	20-1/4	17-7/8
6 x 2	10 x 4	231221	9-3/8	14-1/8	17-7/8	18-3/4
6 x 3	10 x 6	231222	10-7/8	15-7/8	25-3/8	20-3/4
6 x 4	10 x 8	231223	12-3/8	17-1/4	25-7/8	21
8 x 3	12 x 6	231224	11-1/4	17	26-1/4	21-3/8
8 x 4	12 x 8	231225	12-5/8	18-1/4	27-3/8	22-1/4
8 x 6	12 x 10	231226	14-1/8	16-3/4	30-1/4	24-1/8

Double Wye – Socket x Spigot

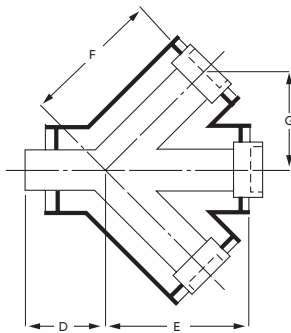

Carrier (in.)	Containment (in.)	Part No.	D (in.)	E (in.)	F (in.)	G (in.)
1-1/2	4	231243	9	8-1/8	9	6-3/8
2	4	231244	8-3/4	8-1/4	8-3/4	6-3/16
3	6	231245	14	9-1/8	13	9-1/4
4	8	231246	16-1/8	10-1/4	16-1/8	11-3/8
6	10	231241	18-3/4	13-7/8	18-3/4	13-1/4
8	12	231242	21-1/8	15-1/2	21-1/8	15

Encase™ Dimensions

Reducer Coupling – Socket x Spigot

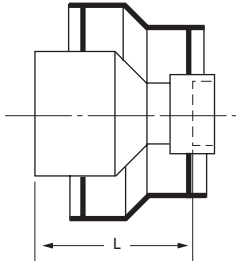

Carrier (in.)	Containment (in.)	Part No.	L (in.)
2 x 1-1/2	4 x 4	231347	5-7/8
3 x 1-1/2	6 x 4	231348	10-3/8
3 x 2	6 x 4	231349	11-3/8
4 x 1-1/2	8 x 4	231324	11-5/8
4 x 2	8 x 4	231350	11-3/4
4 x 3	8 x 6	231351	13-1/4
6 x 1-1/2	10 x 4	231352	18
6 x 2	10 x 4	231341	17-3/4
6 x 3	10 x 6	231342	15-7/8
6 x 4	10 x 8	231343	14-1/2
8 x 3	12 x 6	231344	19-3/4
8 x 4	12 x 8	231345	18-1/2
8 x 6	12 x 10	231346	15-1/4

P-Trap – Socket x Spigot

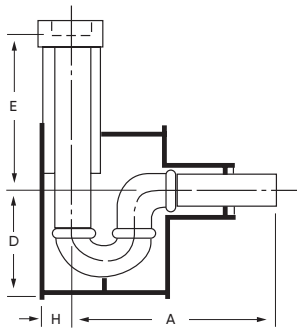

Carrier (in.)	Containment (in.)	Part No.	A (in.)	D (in.)	E (in.)	H (in.)
1-1/2	4	231361	13-3/8	8-1/4	8	3-3/8
2	4	231372	13-1/8	8-1/4	7-3/4	3-3/8

P-Trap – Socket x Spigot

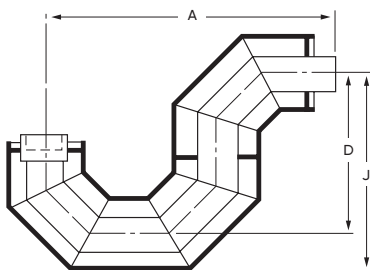

Carrier (in.)	Containment (in.)	Part No.	A (in.)	D (in.)	J (in.)
3	6	231373	31-3/4	22-3/4	26-1/16
4	8	231374	37-1/2	25-1/8	29-3/16
6	10	231371	42	31-5/8	37
8	12	231375	44-5/8	37-1/4	35-1/8

Encase™ Dimensions

Floor Drain – Spigot

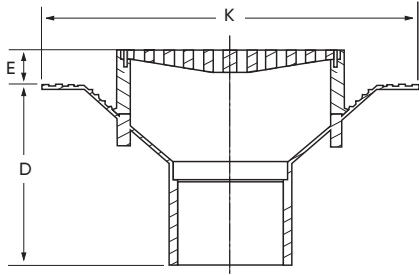

Carrier (in.)	Containment (in.)	Part No.	D (in.)	E (in.)	K (in.)
1-1/2	4	231400	11-1/8	1-1/2	14-1/2
2	4	231402	11-3/8	1-1/2	14-1/2
3	6	231403	6-3/4	1-1/2	14-1/2
4	8	231404	7	1-1/2	14-1/2
6	10	231401	6-5/8	1-1/2	14-1/2

Access Tee – Socket x Spigot x Spigot

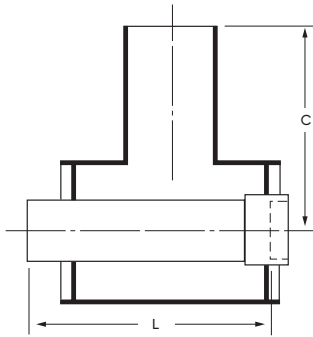

Carrier (in.)	Containment (in.)	Part No.	C (in.)	L (in.)
1-1/2	4	231425	11	15-3/4
2	4	231426	11	15-1/2
3	6 x 4	231421	12	17-1/4
4	8 x 4	231422	13	18-5/8
6	10 x 4	231423	14	21-7/8
8	12 x 4	231424	15	23-1/8

End Seal – Socket x Spigot

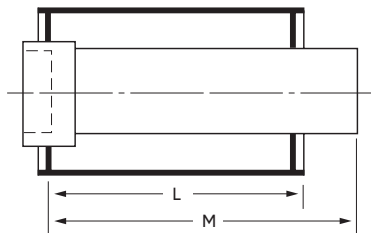

Carrier (in.)	Containment (in.)	Part No.	L (in.)	M (in.)
1-1/2	4	231483	8	24
2	4	231484	7-3/4	24
3	6	231485	8-1/2	24
4	8	231486	7-3/4	24
6	10	231481	6-3/4	24
8	12	231482	6-3/4	24

Encase™ Installation Procedures

Basic Principles

Pipe and Fittings Assembly

All pipes and fittings have a socket welded into position on the upstream side of the component, and a spigot on the downstream side. After fusing the carrier joint, secondary coupling is used to close the containment sections together.

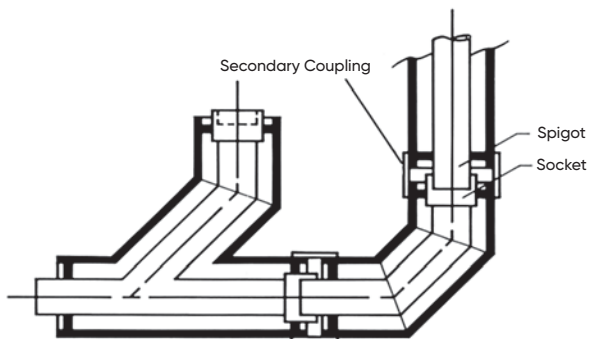

Enfusion™ Joints

Encase is easily joined by Enfield's Enfusion process. Both primary and secondary couplings are manufactured with an integral resistance wire. The wire is electrically heated by a microprocessor controlled Enfusion Handheld Control Unit. This results in fusion, bonding the pipe to the fitting. Joining is achieved within minutes.



The Enfusion joint achieves the optimum level of performance where it matters most – at the joint interface. There is a controlled fit, controlled temperature, and controlled time. All of this is achieved by the Enfusion Handheld Control Unit, which ensures proper electrical connections, joint timing, and input/output levels. The combination of these features provides both simplicity of joining and perfect control. The result is an unparalleled level of joint repeatability.

Job Site Precautions



1. Do not use unit in a gaseous environment as there is a RISK OF EXPLOSION.
2. The unit is a Class 1 device and must be used with a grounded power supply.
3. Only use a hydrostatic test on the system. TESTING WITH AIR IS DANGEROUS FOR A POLYPROPYLENE (PP) ACID WASTE SYSTEM.
4. Store pipe and fittings out of direct sunlight. If material is stored outside, it should be covered with a light-colored opaque tarp. If the ambient temperature exceeds 100°F (37°C), make provisions to allow air to circulate beneath the tarp.
5. Handle the Enfusion Handheld machine carefully. DO NOT TAMPER! Call your IPEX representative for machine service.
6. DO NOT MIX BRANDS. Good joints can only be made using Enfield pipe, fittings, and clamps. Mixing brands voids all warranties.
7. Software version V1.19 on the handheld Enfusion control unit will automatically adjust the fusion cycle time to the ambient temperature. The pipe, fittings, and Enfusion control unit processor must all be allowed to acclimatize to the same temperature.

Handling and Storage

Thermoplastics are strong, lightweight materials, about one-fifth the weight of steel or cast iron. Piping made of this material is easily handled and, as a result, there is a tendency for it to be thrown about on the job site. Care should be taken in handling and storage to prevent damage to the pipe. Some general guidelines are as follows:

- If stored outdoors, best practice dictates that Encase pipe and fittings be covered with a protective cover that is well ventilated. Ideally, pipe and fittings should always be stored inside a building or materials storage trailer.
- Make sure the pipe is adequately supported at all times. Avoid stacking pipe in large piles, since the pipe at the bottom may incur high loads. Store on level support to prevent sagging or bending.
- For long-term storage, use pipe racks to support the pipe continuously along its length. If this is not possible, supports of at least 3 in. bearing width, at spacings not greater than 3 ft centers, are recommended. Pipe should not be stored more than seven layers high. Sharp corners on metal racks should be avoided.
- Pipe is often supplied in crates. Take care when unloading crates and avoid using metal slings or wire ropes. Crates may be stacked four high in the field.
- Exercise care while handling pipe. Damage may occur if pipe collides with sharp corners or is dropped.
- Drainage applications require that the pipe lengths be installed with the required amount of pitch, or fall, to achieve proper drainage flow. Storing pipe in direct sunlight may result in the development of bowing or curving within pipe lengths. Bowing or curving may impede the ability to correctly pitch the pipe to achieve proper drainage flow.
- Extra care should be taken when unloading and handling pipe in cold weather. The impact strength for FRPP and NFRPP is reduced at lower temperatures. Dropping pipe from a truck or forklift may cause damage. Methods and techniques normally used in warm weather may not be acceptable in a lower temperature range.

Prolonged Outdoor Exposure

Prolonged exposure of Encase FRPP and NFRPP to the direct rays of the sun will not damage the pipe material. However, some mild discoloration may take place in the form of a milky film on the exposed surfaces. This color change merely indicates that there has been a harmless chemical transformation at the surface of the pipe. A small reduction in impact strength could occur at the discolored surfaces, but it is of very small order and can be removed during the joining process.

Painting

PP pipe and fittings can be easily protected from ultraviolet oxidation by painting with heavily pigmented, exterior water-based latex paint. The color of the paint is not important; the pigment merely acts as an ultraviolet screen and prevents sunlight discoloration. White or some other light color is recommended since it helps reduce pipe temperature. The latex paint must be thickly applied as an opaque coating on pipe and fittings that have been cleaned well, very lightly sanded, and primed with a latex-based primer.

Encase™ Fusion Instructions

The Encase system is manufactured in modular form from factory-assembled components. Minimal site fabrication is required and therefore site installation time is cut to a minimum. The only joining necessary is to fuse the carrier and containment pipe with Encase couplings. Both carrier and containment joints can be assembled in the trench, or above-ground local to the trench, depending on the site conditions.

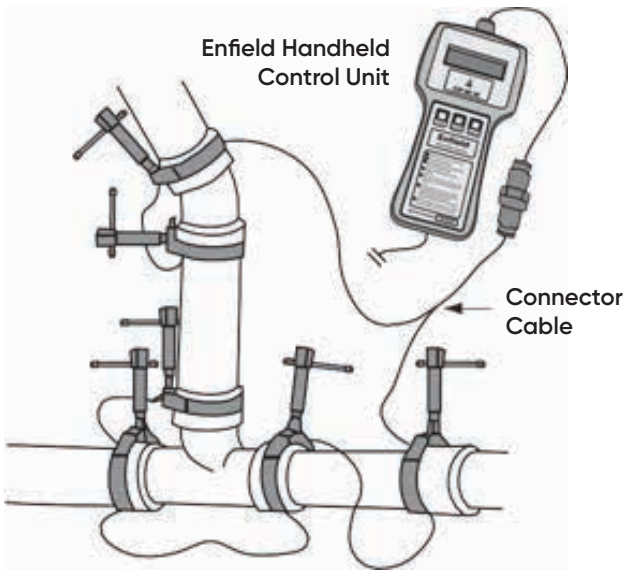

Prior to commencing joining, ensure the trench has been correctly prepared to accept the Encase system.

Suggested trench and bedding preparation details are shown in Section Seven of this manual under "Buried Pipe".

1. After preparing the trench, the Encase components should be placed in position with the pipe ends aligned for joining. Each pipe is labeled to facilitate correct alignment. Make sure there is at least 6" of clearance all around the pipe local to the joints to allow easy access.

2. All fittings have four access ports to allow the fittings to be installed at the desired angle. Both pipe and fittings are supplied with twine to simplify the installation of leak detection cables after carrier joining. Make sure the twine is placed out of the way prior to commencing work.



3. Lay the pipe on sandbags in the trench to facilitate setting the necessary fall on the pipe run to allow free drainage as dictated by the local codes. This also allows easy access for pipe joining.

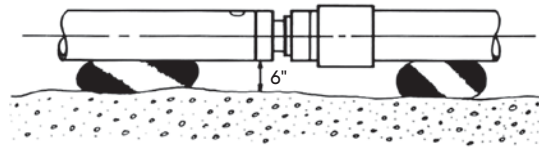

4. Alternatively, the trench bed may be completely covered with sand or pea gravel. In this case, the bedding material must be removed from underneath the containment pipe to a depth of 6" and along a length of three feet on either side of the joint centerline, to allow insertion and fusion of the secondary coupling.

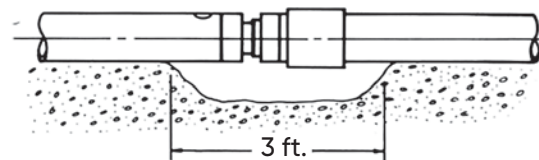

Carrier Pipe Joining

1. Completely unwind all cables from the Enfusion handheld machine's case before use.
2. Using 60-grit emery cloth, prepare the end of the pipe by removing dirt and oil (important to obtain a good bonding surface) and roughing up an area equal to 1.5 times the fitting's socket depth. Clean the roughed-up area with ethyl or isopropyl alcohol to ensure complete removal of grease and residue. Once treated do not handle this area of the pipe or allow it to get dirty.
3. Slide the secondary coupling over the one section of the pipe to be joined so that it is out of the way and does not interfere with the carrier joining process.
4. Align the carrier pipe with the socket fitting. Make sure the carrier joint is squarely aligned before fusion. We suggest a straight edge be placed across the gap (as shown) to ensure the joint is square before joining.
10. Following the "CONNECT LEADS AND FITTINGS" instruction on the display, connect the output leads. If required, connect the link cable for multiple fusions.

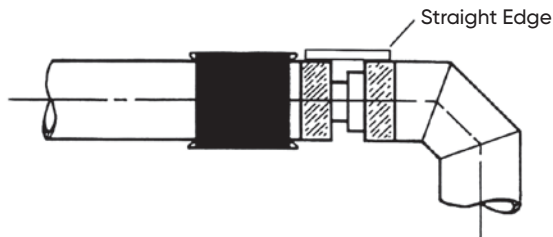
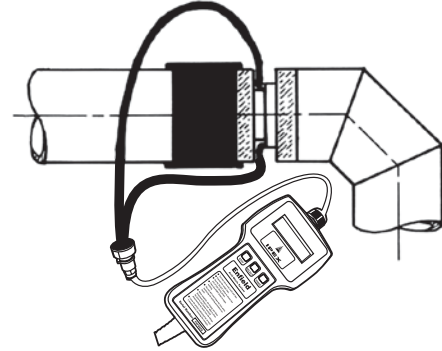

IPEX has developed a revision to its fusion machine software. Your machine will display the software version upon startup, the most recent version being V1.19 (2014). This revision removes the need to select a size range and automatically adjusts the fusion time based on ambient temperature. Allow time for the machine pipe and couplings to acclimatize.

5. Insert the carrier pipe all the way to the stop at the bottom of the socket of the fitting.
6. Decide whether single or multiple joints are being made. In the case of multiple joints, consult the "Multiple Joints Fusion" section that follows for cable connections and the maximum allowable number of simultaneous joints.
7. Loosely fit IPEX-supplied clamp(s) only over the hub(s) of the socket(s) to be fused.
8. Tighten the clamp(s). A tight clamp is essential to the quality of the joint. It should not be possible to rotate the pipe inside the fitting socket when the clamp is fully tightened.
9. Turn the Enfusion Handheld Control Unit on and observe the copyright message and the software version being displayed as the machine runs a self-diagnostic test.
11. With software UPDATE V1.19 (2014), once the leads are connected, you are ready to begin the fusion process. The machine will automatically check to ensure a connection is present and measure the ambient air temperature to set the fusion time. Without the software UPDATE, machines that have NOT been updated will require you to "SELECT SIZE". IPEX recommends the use of the 3" to 12" size range for all fittings regardless of size. (example: 1.5" fittings should use the 3" to 12" selection)
12. To begin the fusion cycle press START. Time will begin to count down to zero.
13. Upon completion of the fusion cycle an audible alarm will sound and the message "WELD COMPLETE DISCONNECT LEADS" will be displayed. A 30-second rest period must be observed to allow the joint(s) to cool before disconnecting the leads. The Enfusion machine will automatically reset, ready for the next operation.
14. Allow five additional minutes before removing the clamps so that the joint can sufficiently cool and properly cure.

Containment Pipe Joining

1. The ends of all fittings and pipe sections are marked with a white line to show where the secondary coupling should be positioned for joining. Make sure that all dirt, oil, water, and grease are removed from the area between the pipe/fitting end and the white line, and then lightly abrade the pipe surfaces with a 60-grip emery cloth.
4. Connect the Enfusion lead to the secondary coupling and complete the Enfusion cycle as described previously in the Carrier Pipe Joining.
5. Leave the joint undisturbed for 10 minutes, after which time the secondary clamps can be removed and the system pressure tested according to the procedures detailed under 'Testing' at the end of this section.

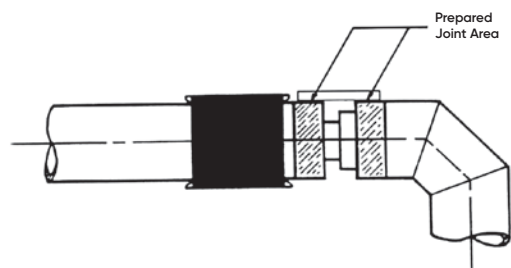

2. Slide the secondary coupling back over the joining area and onto the mating pipe/fitting. The coupling MUST be centrally located between the white lines of the mating components before fusing. The white lines must be visible on both sides of the coupling to ensure proper placement.

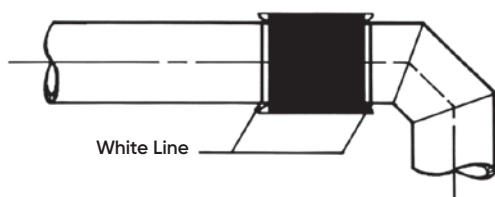

3. Place one secondary clamp on the outside edge of each end of the coupling and tighten. It is usually necessary to tighten by hand followed by three or four turns of a hand wrench to fully lock the secondary coupling into position. It is essential that, after tightening the clamp, the fit of the secondary coupling onto the pipe/fitting is checked. The coupling MUST NOT move. If it does, the clamp should be tightened further until the coupling is FIRMLY LOCKED onto the pipe/fitting.

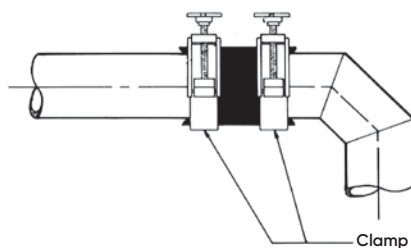

Multiple Joint Fusion – V1.19 Software

Enfield Fusion Times

With the update to the fusion machine software (V1.19, 2014), fusion times are now standard across all sizes. Fusion times will however vary based on the ambient air temperature. As the temperature goes up the fusion time will go down, conversely, as the temperature goes down the time will go up. As a reference: at 73°F (23°C) the fusion time is 125 seconds.

The chart indicates the number of joints for each side that can be fused at one time.

Maximum Allowable Joints Per Size

Pipe Size (inches)	1-1/2	2	3	4	6	8	10	12
Max # of joints	8	6	4	3	2	1	1	1

Attach the connector leads and link cable leads to fitting terminals as shown in the figure below. **The link cables should be connected in series.** Follow the fusion procedure, as outlined in steps 1-13, to complete the multiple fusion.

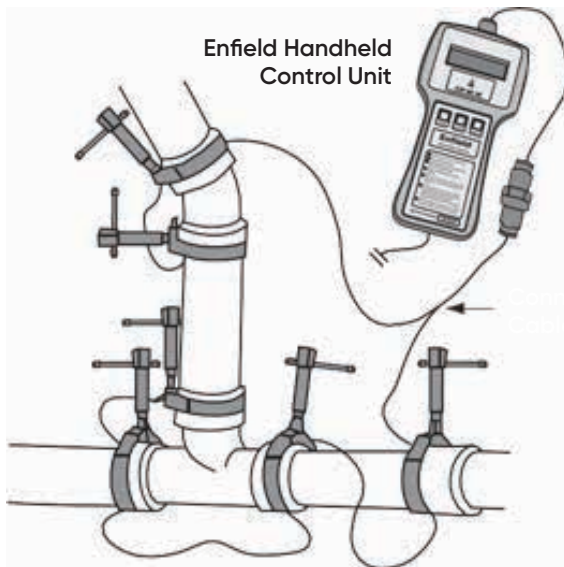

Note: Each joint being fused must have an IPEX T-Bar clamp flush with the other edge of the socket as shown above.

Multiple Joints Across Different Sizes

With the update to the fusion machine software (V1.19, 2014), fusion times are now standard across all sizes, as such the combination of different size fittings that can be fused at the same time is much less restricted.

Any number of fittings or combination of sizes is now possible, provided that when you add the joint diameter sizes up – the total does not exceed 12.

Example A

$1 \times 8''$ and $1 \times 4'' = 12$.

Therefore one 8" fusion joint and one 4" fusion joint could be done at the same time.

Example B

$1 \times 8''$ and $2 \times 3'' = 14$.

Therefore one 8" fusion joint and two 3" fusion joints could not be done at the same time.

Example C

$2 \times 1.5''$ and $2 \times 4'' = 11$.

Therefore two 1.5" fusion joints and two 4" fusion joints could be done at the same time.

Example D

$1 \times 2''$ and $2 \times 6'' = 14$.

Therefore one 2" fusion joint and two 6" fusion joints could not be done at the same time.

Multiple Joint Fusion – V1.17 and Older Software

The chart indicates the maximum number of joints (of one size) that can be fused at a time.

Maximum Allowable Joints Per Size

Pipe Size (inches)	1-1/2	2	3	4	6	8	10	12
Max # of joints	10	8	4	3	2	1	1	1

Attach the connector leads and link cable leads to fitting terminals as shown in the figure on the previous page.

The link cables should be connected in series. Follow the fusion procedure, as outlined in steps 1-14, to complete the multiple fusion.

NOTE: Each joint being fused must have an IPEX clamp flush with the outer edge of the socket.

Multiple Size Joint Fusion

The new handheld control unit utilizes fusion size ranges. These ranges adjust fusion time and output for two groups of fittings; Group A: 1-1/2" to 2" and Group B: 3" to 12". When fusing multiple joints, it is possible to fuse different sizes as long as they are in the same Group and their diameter sizes, when added together, do not exceed an equivalent total of 12.

Example A

1 x 8" and 1 x 4" = 12"

Therefore one 8" fusion and one 4" fusion could be done at the same time.

Example B

1 x 8" and 2 x 3" = 14"

Therefore one 8" fusion and two 3" fusions could not be done at the same time.

The Tables below show all multiple size fusions possible for each fusion range.

Group A: 1-1/2" to 2" Fusion Range

Pipe Size (in)	Multiple Size Joint Fusion Combinations					
	Option A	Option B	Option C	Option D	Option E	Option F
1-1/2"	6	5	4	3	2	1
2	1	2	3	3	4	5
Equivalent Total:	11	11.5	12	10.5	11	11.5

Group B: 3" to 12" Fusion Range

Pipe Size (in)	Multiple Size Joint Fusion Combinations						
	Option A	Option B	Option C	Option D	Option E	Option F	Option G
3	2	2	1	2	1		
4		1	2			1	1
6	1			1		1	
8					1		1
10							
12							
Equivalent Total:	12	10	11	12	11	10	12

Pipe Modifications

Encase pipe is factory-supplied in 20-foot lengths with an electrofusion coupling on one end of the carrier. It may be necessary to modify the pipe length, this can be easily accomplished following the procedure below.

1. Determine the desired length of the carrier pipe and cut to length from the spigot end.
2. Cut the containment pipe to length using the chart below to determine the amount of exposed carrier coupling (A) and spigot (B) required to properly fuse the secondary coupling.

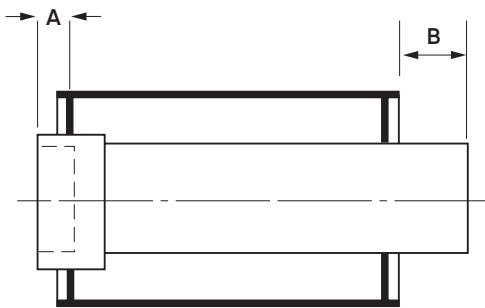

Size (in)	A (in)	B (in)
1-1/2 x 4	3/4	1-3/8
2 x 4	3/4	1-3/8
3 x 6	3/4	1-3/4
4 x 8	3/4	1-7/8
6 x 10	3/4	2-5/8
8 x 12	3/4	2-7/8

Pipe Termination Fittings

Pipes and fittings can be terminated into cleanouts, traps, or flanges/blind flanges, using termination fittings.

Termination fittings are used where the containment pipe section is ending, but the carrier pipe is continued. The termination fitting is shown below, with a blind downstream anchor plate.

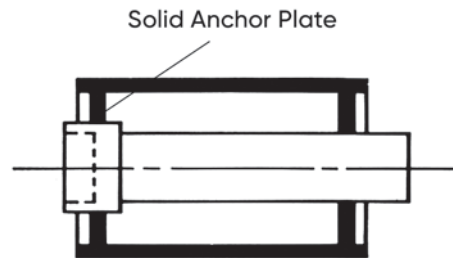

Fault Code Analysis

FAULT NUMBER AND CODE		ACTION
0	WELD OK	No Fault, weld completed OK.
1	STUCK BUTTON ON START UP	This fault shows when the power is first switched on. Either the Stop, Start, or a keypad button is stuck in. Free the button to clear the fault.
2	OUTPUT FAULT BEFORE WELD START	This fault shows when the power is first switched on. The unit will check the output relay to make sure it is working correctly. If this fault happens, then the internal power relays have pulled into the closed position. Return unit for service.
4	NO CALIBRATION	This fault happens when the unit has no calibration. This normally does not show, and if the unit has been calibrated, would be caused by a fault with the internal memory. Return unit for service.
7	AMBIENT TEMPERATURE TOO HIGH	If the ambient temperature is measured at over +50°C (122°F) then this fault will show.
8	AMBIENT TEMPERATURE TOO LOW	If the ambient temperature is measured at below -20°C (-4°F) then this fault will show.
9	AMBIENT TEMPERATURE FAULT	This fault is shown if the temperature is measured as less than -100°C (-148°F) or more than +100°C (212°F). This effectively means a short circuit or open circuit sensor.
10	LOW SUPPLY FREQUENCY <40HZ	The unit has detected that the supply frequency is below 40 Hz. This will normally be caused by a poor quality generator. If this fault happens, then check the supply or change the generator.
11	HIGH SUPPLY FREQUENCY >70HZ	The unit has detected that the supply frequency is above 70 Hz. This will normally be caused by a poor quality generator. If this fault happens, then check the supply or change the generator.
12	HI SUPPLY VOLTAGE >140V	The unit has detected that the supply voltage is more than 140 volts. Check the supply voltage and if necessary use a different generator.
13	LOW SUPPLY VOLTAGE <95V	<p>This fault can be caused by a few problems. It could be that the generator is running slowly and so the supply voltage is low. Try speeding the generator up or use a different generator.</p> <p>It could also be caused by a generator that is too small. If a large fitting is welded, then a large amount of power will be needed from the generator. If it cannot supply this power, then it will stall and the voltage will drop away. Check that the generator is the correct size, if needed try another generator.</p> <p>It could be caused by the use of long extension leads. If a large fitting is welded, then a high current will be taken from the supply. If extension leads are used, there will be a volts drop down the lead making the unit sense a low supply voltage. Try not to use extension leads with the unit. If you must, then use just 30 feet of cable, the same size fitted to the unit.</p>

Fault Code Analysis

FAULT NUMBER AND CODE		ACTION
14	RELAY FAILED TO LATCH ON WELD START	This fault could happen when the start button is pressed. If the main power relays do not operate correctly, then this fault will be shown. Return unit for service.
20	WELDING CURRENT EXCESSIVE (>150%)	This fault will happen if the welding current is more than 50% high for more than 0.3 seconds. this fault is normally caused by a fault with the unit, a short circuit triac. Return unit for service.
21	WELDING CURRENT HIGH (>125%)	This fault will happen if the welding current is more than 25% high for more than 1 second. This fault is normally caused by a fault within the unit, a short circuit triac. Return unit for service.
22	WELDING CURRENT HIGH (>112.5%)	This fault will happen if the welding current is more than 6.25% high for more than 2 seconds. this fault will normally be caused by a poor quality generator with the supply voltage fluctuating. Try a different generator.
23	WELDING CURRENT HIGH (>106.25%)	This fault will happen if the welding current is more than 6.25% high for more than 2 seconds. this fault will normally be caused by a poor quality generator with the supply voltage fluctuating. Try a different generator.
24	WELDING CURRENT HIGH (>101.5%)	This fault will happen if the welding current is more than 1.5% high for more than 3 seconds. This fault will normally be caused by a poor quality generator with the supply voltage fluctuating. Try a different generator.
25	USER STOP BUTTON PRESSED	The operator has pressed the stop button.
26	RELAY UNLATCHED	During welding, if the main power relay disconnects, then this fault will be shown. It could be caused by the unit being knocked or a temporary dip in the power supply.
27	FITTING OPEN CIRCUIT	This fault is shown if the output lead disconnects from the fitting while welding. Follow the guidelines from this manual to reconnect the lead and try welding again.
28	WELDING CURRENT LOW (<98.5%)	This fault will happen if the welding current is more than 1.5% low for more than 3 seconds. This can be caused by a generator that is not big enough to supply the required power to the fitting. Check the size of the generator and if needed try another generator. It can also be caused by using long extension leads with the unit. It is recommended that only 30 feet of extension are used, and the cable should be the same thickness as the input lead on the unit.
29	WELDING CURRENT LOW (<50%)	This fault will happen if the welding current is more than 50% low for more than 1 second. It can be caused by a faulty fitting. Try another fitting. If this doesn't clear the fault, then there is a problem inside the unit. Return unit for service.
127	POWER OFF FAILURE	If the power is turned off while the unit is welding, this fault will be recorded to the catalogue.

Machine Repair Information

Repair Information

There are no user-serviceable parts inside the welding unit. If an internal fault happens with the unit then it must be returned to IPEX for repair. Please contact your local IPEX distributor for instructions on the proper return of your Enfield unit.

Specification for Enfield Handheld Control Unit

Operating Mode	Enfield Automatic
Operating Language	English
Operating Temperature Range	0°F to 120°F
Input Voltage	120 V ac 95V to 140V
Input Current	10.5A
Input Frequency	50 Hz 40 Hz to 70 Hz
Input Power	100 VA to 1250 VA
Output Current	18 A ac true rms
Output Voltage	3 V to 50 V ac true rem
Output Power	50 W to 900 W
Output Stability	+/-1.5%
Power Factor	0.72
Unit Weight	33 lb
Handheld Weight	2.2 lb
Size	15.7" x 12.6" x 6.3"
Environmental Protection	IP65
Lead Length (to power case)	16.5 ft
Lead Length (to handheld unit)	33 ft
Lead Length (to fitting)	6.6 ft

NOTES: Screen the joints being fused from the wind in very cold conditions to prevent heat loss.

Particular care must be taken to adequately tighten the clamps during extremely cold weather because of increased stiffness of the materials. One or two additional turns of the tightening screw might be required, above and beyond what is commonly sufficient in fair weather conditions. This is particularly true when welding large diameters.

For Enfield Handheld Control Units running software older than V1.19, the additional tightening of the clamps, designed to eliminate any gap between the pipe and the fitting, should be performed towards the end of the flash cycle.

However, care must be taken not to over-tighten to avoid distorting or crushing the fitting joint.

Marking of the pipe (indicating socket depth) is also recommended to assure that the pipe remains fully seated in the socket during the fusion cycle.

Cold Weather Fusion

Whenever possible pipe and fittings should be stored indoors. It is always preferable to perform pipe preparation and welding in a protected environment. However, should that not be possible, during cold weather (particularly at freezing or below) it is recommended that both pipe and fittings be stored in similar ambient temperature and conditions.

In cold weather applications, the lower operating temperature limit (0°F) of the Enfield Handheld Control Unit must be strictly followed.

If ambient conditions during the installation fall below 0°F, postpone installation until ambient installation temperatures have increased to fall within the Operating Temperature Range of the Enfield Handheld Control Unit.

Daily, weekly or seasonal temperature fluctuations may result in thermal expansion and/or contraction of the piping system. Refer to the System Design section of this manual for suitable techniques for accommodating thermal expansion and contraction and consult the Engineer of Record.

In addition, when the actual welding takes place in freezing or sub-freezing environments, this cold weather pre-fusion procedure must be followed.

NOTE: Enfield Handheld Control Unit software update V1.19 will automatically adjust the fusion time as the ambient temperature changes. The following procedure is required for Enfield Handheld Control Unit running software older than V1.19.

1. Follow steps 1 through 9 of Standard Enfield Electrofusion Installation.
2. When the "SELECT SIZE" prompt appears on the screen keep pushing the select button until all pipe sizes have been displayed.
3. Next will appear the first flash cycle: 1-1/2" to 2".
4. If the fitting(s) being welded is within this flash range, press START.
5. If the fitting(s) being welded is not included in this flash range, press the SELECT button one more time to display the second flash cycle: 3" through 12".
6. Press START.
7. Upon completion of the flash cycle, the display will show the "WELD COMPLETE DISCONNECT LEAD" message. Do not disconnect the leads.
8. Tighten clamps if necessary (see notes below).
9. Allow 1-1/2" to 3" joints to cool for 5 minutes, 4" to 8" joints to cool for 7 minutes and 10" to 12" joints to cool for 10 minutes before beginning the fusion cycle.
10. After cooling, continue with steps 10 through 14 of the Standard Enfield Electrofusion Installation procedure.

Testing

The purpose of a site pressure test is to establish that all joints have been correctly made. Encase allows for the individual testing of the carrier and containment piping.

Carrier Pipe

Hydrostatic testing of the carrier joint can be performed ten minutes after the final carrier joint has been completed. The pressure testing procedure detailed below should be strictly followed.

1. Fully inspect the installed piping for evidence of mechanical abuse and suspect joints.
2. Split the system into convenient test sections, not exceeding 1,000 ft. The piping should be capped off with an expandable plug at the end of the pipe section to be tested.
3. Prior to starting the test, straight lengths of pipe should be backfilled between fittings that are tested.
4. Slowly fill the pipe section with cold water, taking care to evaluate all trapped air in the process. Use air release valves in any high spots in the system. Do not pressurize at this stage.
5. Leave the pipe for at least one hour to allow an equilibrium temperature to be achieved.
6. Visually check the system for leaks. If clear, check for and remove any remaining air from the system.
7. Pressurize the system to a suggested maximum of 10 feet head by means of a standard 10-foot standing water test using a 10-foot vertical riser, or a low-pressure hand pump.
8. Leave the line at 10 feet head for a period of up to eight hours, during which time the water level should not change (standing water test), nor should the pressure gauge reading change (hand pump test).
9. If there is a significant pressure drop, or extended times are required to achieve the desired pressure, either joint leakage has occurred or air is still entrapped in the line. In this event, inspect for joint leaks. If none are found, check for entrapped air – this must be removed prior to continuing the test.
10. If joints are found to be leaking, the system must be fully drained and the joints repaired. Dry or marginally fused Enfield joints can be re-fused by following steps 5 through 13 in the Standard Enfield Electrofusion Installation procedure. To remove moisture from the joint, use the drying cycle.
 - To dry the Enfield joint using the handheld Enfusion machine with software V1.19, users need to connect the leads and fittings. The machine will prompt the user to "PRESS START". The user needs to press the "SELECT" button and then the "START" button immediately after. The drying cycle will appear with a 45-second count down.
 - Allow the joint to cool.
 - Now re-fuse using the correct Enfusion machine settings for the size of pipe being joined following steps 5-13 of the Standard Enfield Electrofusion Installation procedure.
 - Should any of the re-welded fitting(s) fail the second hydro-test, the leaking joint(s) can be back-welded with a hot-air gun and welding rod. Should the back-welded joint(s) fail a third hydro-test, they will need to be cut out of the system and substituted with new fittings.
 - If a joint has to be cut out and replaced, the procedure for pipe modification detailed in this manual should be strictly followed.
11. Repeat the 10 feet head test after repairing any leaking joints, following the procedure described above.

Containment Pipe – Testing

After successfully completing the carrier pipe's 10-foot head, hydrostatic pressure joint integrity test, the containment pipe can be joined and tested.

Air Testing

For systems containing: cable leak detection, low points not easily drained, P-traps, or where it is not possible to dry out the interstitial space, it may be necessary to conduct a pneumatic joint integrity test; subject to the engineer and/or authority having jurisdiction. This alternative joint integrity test uses dry, low-pressure air.

1. Leave the carrier pipe at a 10-foot head hydrostatic pressure.
2. Slowly pressurize the containment pipe with air to a MAXIMUM of 5 psi for 1 hour, using a similar test assembly as shown. To ensure that the pressure does not exceed 5 psi, the testing equipment should also include a pressure regulator or pressure relief valve (set at no higher than 5 psi) and a pressure gauge.
3. While taking great care not to impact or damage the containment pipe, the exposed containment joints should be wiped with an IPEX-approved leak detector. In addition, check the pressure gauge to make sure that there is no pressure decay.
4. It is essential that the system is closely monitored and that the pipe suffers no impact or other damage during the test.

NOTE: For more information on lower pressure air testing of thermoplastic piping systems, reference Unibell B-6.



WARNING

Take special care to avoid causing impact to the piping when testing the interstitial space of rigid thermoplastic systems using compressed gases. Impact to the system during air testing can cause failure which may result in injury or death.

Conduct this test only when the ambient temperature is 50°F or above.

The containment pipe should never be pressurized to any more than 5 psi when using air.

Pipe Repair

In the unlikely event of a leak from the carrier pipe, Encase can be easily repaired. Encase containment piping is designed with the same chemical resistance and integrity as the carrier pipe. This means that the Encase system can continue to be used even after a leak has been detected. This enables the end-user to make the necessary repairs during a scheduled shutdown rather than having to instantly shut the plant down, with the consequential loss of production.

Procedure

The leak detection system will activate an alarm and indicate the location of the leak (generally to within +/- 5 feet of the leak source for cable leak detection). Having been alerted to the presence of a leak, the plant operator may choose to either start immediate repairs or wait for a scheduled maintenance shutdown. In any event, the plant operator should repair the pipe in the following manner:

Pipes and fittings can be terminated into cleanouts, traps, or flanges/blind flanges, using termination fittings.

Termination fittings are used where the secondary pipe section is ending, but the primary pipe is continued. The termination fitting is shown below, with a blind downstream anchor plate.

End Caps and Flanges/Blind Flanges

End caps and flanges are socket-ended and can be fused to either the primary or secondary pipe runs to provide a termination to the containment system.

In the unlikely event of a leak from the primary pipe,

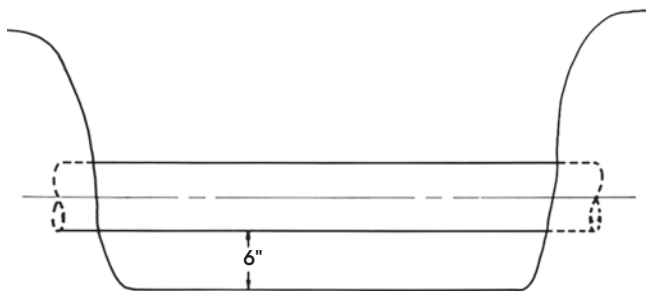

Encase can be easily repaired. Encase secondary piping is designed with the same chemical resistance and integrity as the primary pipe. This means that the Encase system can continue to be used even after a leak has been detected. This enables the end-user to make the necessary repairs during a scheduled shutdown rather than having to instantly shut the plant down, with the consequential loss of production.

5. Mark the containment pipe dimension 'A' from the end as shown in the table below and transpose this mark around the containment pipe circumference.

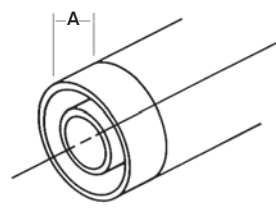

Carrier/ Containment Size (in)	Gap (in)
1-1/2 / 4	1-1/8
2 / 4	1-3/8
3 / 6	1-7/8
4 / 8	1-7/8
6 / 10	2-5/8
8 / 12	2-7/8

6. Cut squarely through the containment pipe ends, taking care not to cut into the carrier pipe. Clean any burrs from pipe ends.

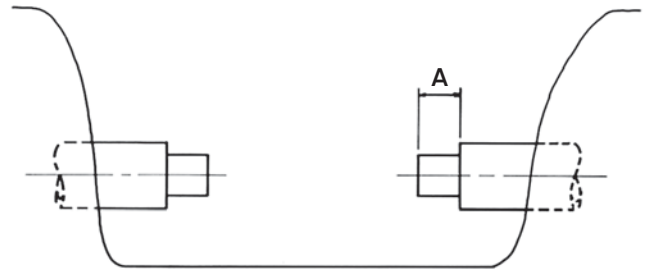

7. Mark a pencil line on the ends of each carrier and containment pipe section to locate the joining position for the primary and secondary repair couplings. The pencil line should be at the following distances from the pipe ends.

Carrier Size (in)	Carrier Mark (in)	Containment Size (in)	Containment Mark (in)
1-1/2	3/4	4	2-1/8
2	1	4	2-1/8
3	1-3/8	6	1-7/8
4	1-1/2	8	1-7/8
6	2	10	1-1/8
8	2-1/4	12	2-7/16

Pipe Repair

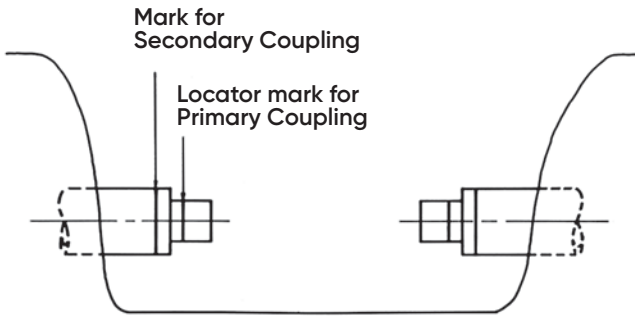

- Slide one secondary repair coupling over each end of the exposed containment pipe sections, and one primary repair coupling over the exposed spigots of the carrier pipe sections.

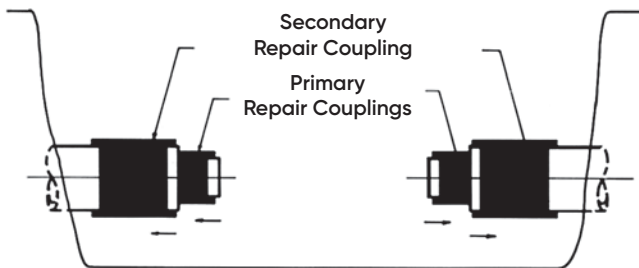

- Measure, prepare and insert a pipe spool piece into the line to be repaired. For dimensions refer to the table that follows.

Note: IPEX will cut and supply short pipe lengths to suit site conditions. Please contact our Customer Service Representatives for details.

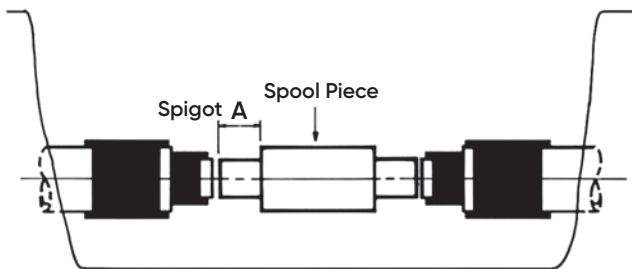

Carrier Size (in.)	Containment Size (in.)	Spigot A (in.)
1-1/2	4	1-1/8
2	4	1-3/8
3	6	1-3/4
4	8	1-7/8
6	10	2-5/8
8	12	2-7/8

- Prepare the carrier and containment pipe sections for joining, as described earlier in "Encase Fusion Procedure"
- Slide the primary repair couplings back into position to close the joint. Make sure they are centrally located between the pencil marks previously scribed onto the carrier spigot ends. Place the hub clamps over the primary repair couplings and fuse the joints in the normal manner.

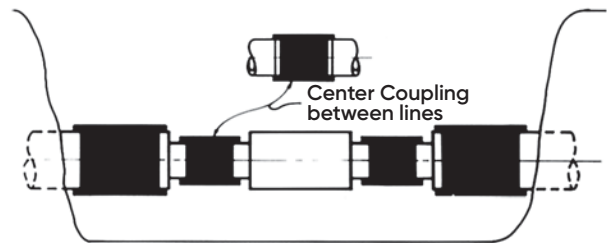

- Remove the hub clamps after allowing the joints to cool for 10 minutes.
- Test the carrier joints as detailed in the next section.
- Slide the secondary repair couplings into position between the pencil lines previously scribed onto containment pipe ends. Place the secondary clamps over the secondary repair couplings and fuse the joints as described in the Encase Fusion Procedure – Containment Pipe.

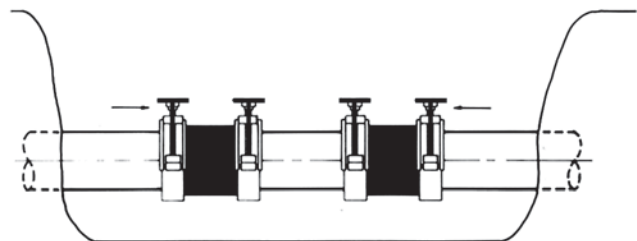

Pipe Repair

15. Remove the hub clamps after allowing the joints to cool for 10 minutes.
16. Test the containment joints as detailed in the Testing section, then fully drain the system.
17. Surround the pipe with pea gravel, then backfill and consolidate.

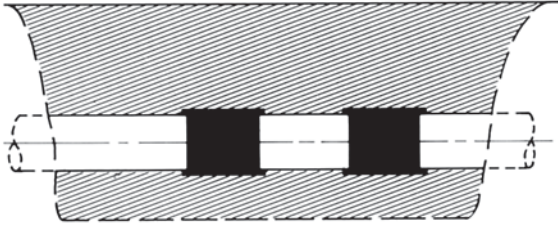

18. Purge the gap between the carrier and containment pipe section with dry nitrogen, or air, making sure the pressure does not exceed 5 psi.
19. Close any drain valves.

SECTION THREE: GUARDIAN™ & CLEAR-GUARD™

Guardian™ & Clear-Guard™ Overview

Introduction

Xirtec® PVC and Xirtec® CPVC are the chosen materials for the Guardian and Clear-Guard (PVC only) systems. IPEX controls not only the design and fabrication of the systems but also the blending of the PVC resin, the extrusion, and injection molding of most components. This unparalleled consistency of quality and resin as well as dimensional compatibility results in superior systems that are unmatched in the industry.

Design

Guardian and Clear-Guard systems offer a complete selection of pretested modular components which are extremely easy to install.

Our Centra-Lok™ patented design allows IPEX to offer vinyl systems that average up to 60% fewer overall joints and up to 10% fewer field joints. Since joints are always the most common source of premature failures and leaks, it is easy to realize the immense impact the Centra-Lok design has on maintenance, repair, and installation costs. The patented ingenuity and simplicity of the Centra-Lok design also reduces the purchase cost of IPEX systems, making Guardian and Clear-Guard the industry's most cost-effective vinyl system.

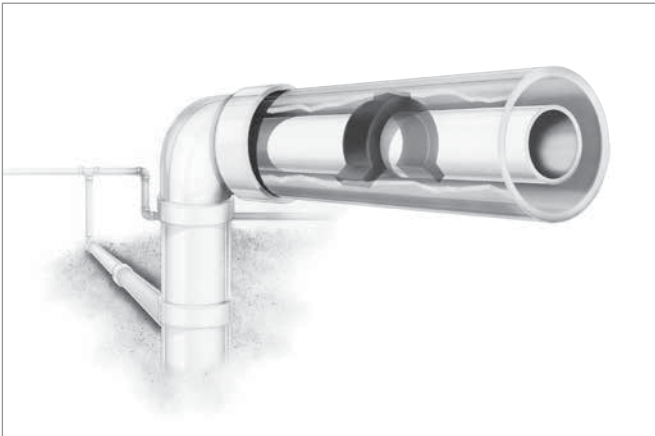

As with all our containment systems, the IPEX patented Centra-Guard™ electric low point or continuous cable leak detection systems are also available.



GUARDIAN

CLEAR-GUARD

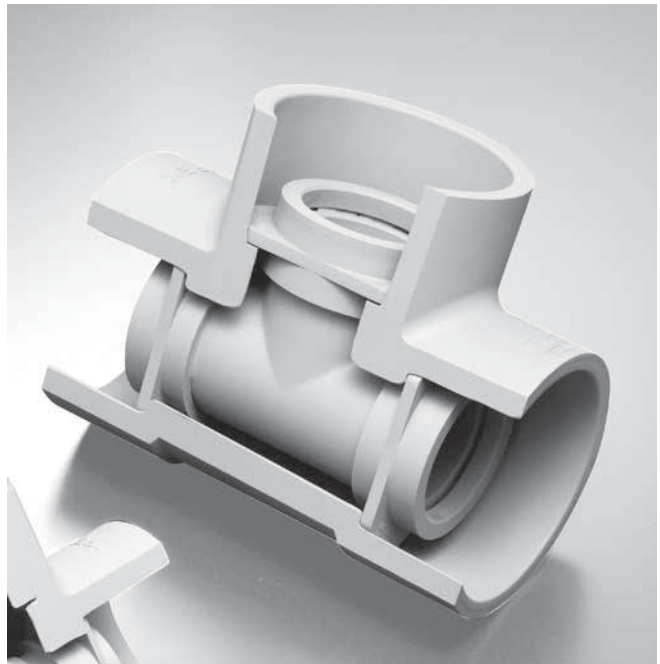

Guardian™ & Clear-Guard™ Dimensions

The following dimensional drawings are for both Guardian and Clear-Guard systems.

* Clear-Guard Systems are only available up to 8" containment pipe *

Vinyl / Vinyl Pipe

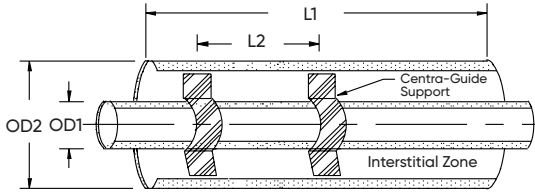

Carrier / Containment (in.)	L1 (ft)	L2 (ft)	OD1 (in.)	OD2 (in.)
1/2 x 2	20	3	0.84	2.38
1/2 x 3	20	3	0.84	3.50
3/4 x 3	20	3	1.05	3.50
1 x 3	20	3	1.32	3.50
3/4 x 4	20	3	1.05	4.50
1 x 4	20	3	1.32	4.50
1-1/2 x 4	20	4.5	1.90	4.50
2 x 4	20	4.5	2.38	4.50
2 x 6	20	4.5	2.38	6.62
2-1/2 x 6	20	4.5	2.88	6.62
3 x 6	20	4.5	3.50	6.62
4 x 8	20	4.5	4.50	8.62
6 x 10	20	4.5	6.62	10.75
8 x 12	20	4.5	8.62	12.75
10 x 14	20	4.5	10.75	14.00
12 x 18	20	4.5	12.75	18.00

Vinyl / Vinyl Centra-Lok™ Tee

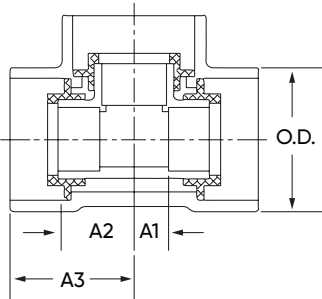

Sch 80 / Sch 80

Carrier / Containment (in.)	A1 (in.)	A2 (in.)	A3 (in.)	O.D. (in.)
1/2 x 2	0.52	1.48	2.85	2.95
3/4 x 3	0.60	2.03	3.85	4.20
1 x 3	0.80	2.03	3.85	4.20
1 x 4	0.80	2.65	4.70	5.30
1-1/2 x 4	1.08	2.65	4.70	5.30
2 x 4	1.35	2.65	4.70	5.30
2 x 6	1.35	3.75	6.50	7.60
2-1/2 x 6	1.50	3.75	6.50	7.60
3 x 6	1.90	3.75	6.50	7.60
4 x 8	2.40	4.80	8.65	9.90
6 x 10	3.50	6.15	11.40	12.20
8 x 12	4.55	7.25	13.50	14.40

Sch 80 / Sch 40

Carrier / Containment (in.)	A1 (in.)	A2 (in.)	A3 (in.)	O.D. (in.)
1/2 x 2	0.52	1.37	2.50	2.70
3/4 x 3	0.60	1.93	3.70	4.00
1 x 3	0.80	1.93	3.70	4.00
1 x 4	0.80	2.55	4.30	5.00
1-1/2 x 4	1.08	2.55	4.30	5.00
2 x 4	1.35	2.55	4.30	5.00
2 x 6	1.35	3.85	6.60	7.50
2-1/2 x 6	1.50	3.85	6.60	7.50
3 x 6	1.90	3.85	6.60	7.50
4 x 8	2.40	4.80	8.65	9.90
6 x 10	3.50	6.15	11.40	12.20
8 x 12	4.55	7.25	13.50	14.40

Vinyl / Vinyl Centra-Lok™ 90° Elbow

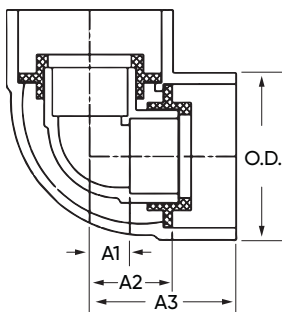

Sch 80 / Sch 80

Carrier / Containment (in.)	A1 (in.)	A2 (in.)	A3 (in.)	O.D. (in.)
1/2 x 2	0.55	1.48	2.85	2.70
1/2 x 3	0.55	1.98	3.75	4.00
3/4 x 3	0.75	1.98	3.75	4.00
1 x 3	0.80	1.98	3.75	4.00
3/4 x 4	0.75	2.55	4.60	5.30
1 x 4	0.80	2.55	4.60	5.30
1-1/2 x 4	1.00	2.55	4.60	5.30
2 x 4	1.35	2.55	4.60	5.30
2-1/2 x 6	1.74	3.75	6.50	7.60
3 x 6	1.85	3.75	6.50	7.60
4 x 8	2.30	4.80	8.75	10.20
6 x 10	3.50	6.07	11.32	12.20
8 x 12	4.55	7.20	13.45	14.40

Sch 80 / Sch 40

Carrier / Containment (in.)	A1 (in.)	A2 (in.)	A3 (in.)	O.D. (in.)
1/2 x 2	0.55	1.37	2.50	2.70
1/2 x 3	0.55	1.98	3.75	4.00
3/4 x 3	0.75	1.98	3.75	4.00
1 x 3	0.80	1.98	3.75	4.00
3/4 x 4	0.75	2.55	4.60	5.00
1 x 4	0.80	2.55	4.60	5.00
1-1/2 x 4	1.00	2.55	4.60	5.00
2 x 4	1.35	2.55	4.60	5.00
2-1/2 x 6	1.74	3.75	6.53	7.50
3 x 6	1.85	3.75	6.53	7.50
4 x 8	2.35	4.85	8.60	10.20
6 x 10	3.50	6.07	11.32	12.20
8 x 12	4.55	7.20	13.45	14.40

Guardian™ & Clear-Guard™ Dimensions

Vinyl / Vinyl Centra-Lok™ 45° Elbow

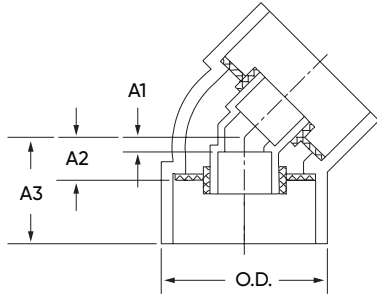

Sch 80 / Sch 80

Carrier / Containment (in.)	A1 (in.)	A2 (in.)	A3 (in.)	O.D. (in.)
1/2 x 2	0.34	0.74	2.10	3.00
1/2 x 3	0.34	0.85	2.63	4.15
3/4 x 3	0.34	0.85	2.63	4.15
1 x 3	0.33	0.85	2.63	4.15
1 x 4	0.33	1.19	3.24	5.25
1-1/2 x 4	0.40	1.19	3.24	5.25
2 x 4	0.60	1.19	3.24	5.25
2-1/2 x 6	0.72	2.01	4.76	7.55
3 x 6	0.73	2.01	4.76	7.55
4 x 8	0.94	2.50	6.25	9.90
6 x 10	1.76	2.73	7.98	12.15
8 x 12	2.25	3.25	9.50	14.30

Sch 80 / Sch 40

Carrier / Containment (in.)	A1 (in.)	A2 (in.)	A3 (in.)	O.D. (in.)
1/2 x 2	0.34	0.76	1.88	2.75
1/2 x 3	0.34	0.91	2.68	4.00
3/4 x 3	0.34	0.91	2.68	4.00
1 x 3	0.33	0.91	2.68	4.00
1 x 4	0.33	1.30	3.10	5.05
1-1/2 x 4	0.40	1.30	3.10	5.05
2 x 4	0.60	1.30	3.10	5.05
2-1/2 x 6	0.72	2.13	5.13	7.40
3 x 6	0.73	2.13	5.13	7.40
4 x 8	0.94	2.45	6.20	9.40
6 x 10	1.76	2.73	7.98	11.60
8 x 12	2.25	3.25	9.50	13.80

Vinyl Termination Fitting

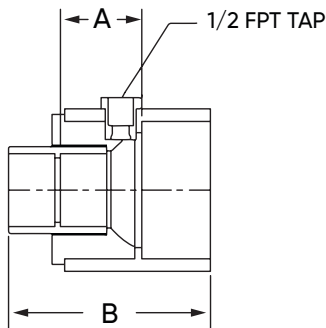

Carrier / Containment (in.)	A (in.)	B (in.)
1/2 x 2	1.80	4.38
1/2 x 2 with TAP*	3.34	5.88
3/4 x 3	2.35	5.38
1 x 3	2.85	6.00
1-1/2 x 4	3.15	6.60
2 x 4	3.05	7.00
3 x 6	3.63	8.75
4 x 8	5.38	12.38

* 1/2 x 2 with TAP utilizes a unique containment style to allow TAP installation

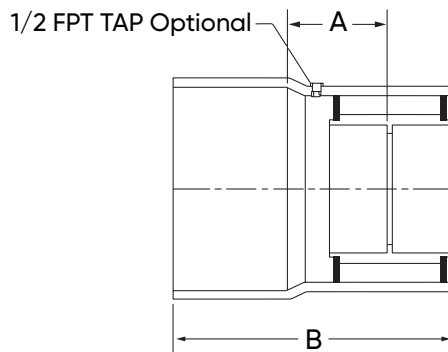

Carrier / Containment (in.)	A (in.)	B (in.)
6 x 10	6.75	15.50
8 x 12	9.75	20.50

Guardian™ & Clear-Guard™ Installation Procedures

Basic Principles

Solvent Welding

To make consistently tight joints, the following points should be clearly understood:

1. The joining surfaces must be softened and made semi-fluid.
2. Sufficient cement must be applied to fill the gap between pipe and fittings.
3. Assembly of pipe and fittings must be made while the surfaces are still wet and fluid.
4. Joint strength will develop as the cement cures. In the tight part of the joint, surfaces tend to fuse together; in the loose part, the cement bonds to both surfaces.

These areas must be softened and penetrated

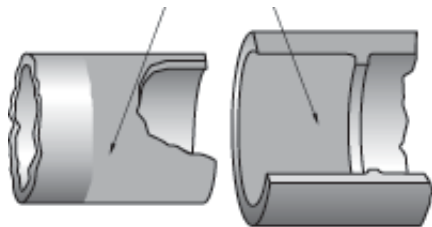

Penetration and softening can be achieved by the cement itself, by using a suitable primer, or by the use of both primer and cement. For certain materials and in certain situations, it is necessary to use a primer. A suitable primer will usually penetrate and soften the surfaces more quickly and effectively than cement alone. Additionally, the use of a primer can provide a safety factor for the installer, for he can know under various temperature conditions when he has achieved sufficient softening. For example, in cold weather, more time and additional applications may be required.

Apply generous amounts of cement to fill the loose part of the joint. In addition to filling the gap, adequate cement layers will penetrate the surfaces and remain wet until the joint is assembled. To prove this, apply two separate layers of cement on the top surface of a piece of pipe. First, apply a heavy layer of cement; then alongside it, a thin, brushed-out layer. Test the layers every 15 seconds by gently tapping with your finger. You will note that the thin layer becomes tacky and then dries quickly (probably within 15 seconds); the heavy layer will remain wet much longer.

Check for penetration a few minutes after applying these layers by scraping them with a knife. The thin layer will have little or no penetration, while the heavy layer will have achieved much more penetration.

If the cement coatings on the pipe and fittings are wet and fluid when assembly takes place, they tend to flow together, becoming one cement layer. Also, if the cement is set, the surfaces beneath the pipe and fittings will still be soft.

These softened surfaces in the tight part of the joint will fuse together. As the solvent dissipates, the cement layer and the softened surfaces will harden with a corresponding increase in joint strength. In the tight (fused) part of the joint, strength will develop quicker than in the looser (bonded) part of the joint.

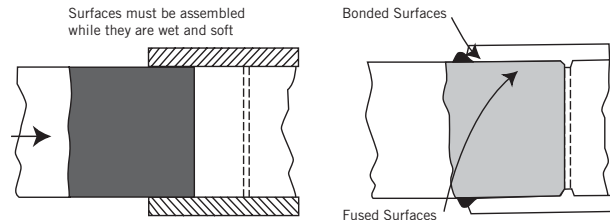

Cement Types

The use of a reliable cement, specifically manufactured for industrial PVC or CPVC, is critical to a good, long-lasting system and must conform to applicable ASTM standards. Review the table below for guidelines on cement types.

Cement Types			
Pipe Size	Pipe Schedule	Socket Type	Cement Type
up to 6" PVC up to 4" PVC	40 80	All types	Medium-bodied fast-setting cement Use primer to soften and prepare joining surfaces
up to 12" PVC	All	All types	Heavy-bodied medium-setting cement for all schedules through 12" diameter water lines, drain lines and DWV Use primer to soften and prepare joining surfaces
up to 30" PVC	All	All types	Extra heavy-bodied slow-setting cement Use primer to soften and prepare joining surfaces
up to 12" CPVC	All	All types	Heavy-bodied medium-setting cement for pressure and non-pressure service Use primer to soften and prepare joining surfaces
up to 16" CPVC	All	All types	Extra heavy-bodied slow-setting cement Use primer to soften and prepare joining surfaces

Handling and Storage



PVC and CPVC are strong, lightweight materials, about one fifth the weight of steel or cast iron. Piping made of this material is easily handled and, as a result, there is a tendency for them to be thrown about on the jobsite. Care should be taken in handling and storage to prevent damage to the pipe.

PVC and CPVC pipe should be given adequate support at all times. It should not be stacked in large piles, especially in warm temperature conditions, as bottom pipe may become distorted and joining will become difficult.

For temporary storage in the field when racks are not provided, care should be taken that the ground is level and free of sharp objects (i.e. loose stones, etc.). Pipe should be stacked to reduce movement, but should not exceed three to four layers high.

Pipe is supplied in crates. Care should be taken when unloading the crates; avoid using metal slings or wire ropes. Crates may be stacked four high in the field.

Since the soundness of any joint depends on the condition of the pipe end, care should be taken in transit, handling and storage to avoid damage to these ends. The impact resistance and flexibility of both PVC and CPVC pipe are reduced by lower temperature conditions. The impact strength for both types of piping materials will decrease as temperatures approach 32°F (0°C) and below. Care should be taken when unloading and handling pipe in cold weather.

Dropping pipe from a truck or forklift may cause damage. Methods and techniques normally used in warm weather may not be acceptable at the lower temperature range.

When loading pipe onto vehicles, care should be taken to avoid contact with any sharp corners (i.e. angle irons, nail heads, etc.), as the pipe may be damaged.

While in transit, pipe should be well secured and supported over the entire length and should never project unsecured from the back of a trailer.

Larger pipe may be off-loaded from vehicles by rolling them gently down timbers, ensuring that they do not fall onto one another or onto a hard, uneven surface.

Prolonged Outdoor Exposure

Prolonged exposure of PVC and CPVC pipe to the direct rays of the sun will not damage the pipe. However, some mild discoloration may take place in the form of a milky film on the exposed surfaces. This change in color merely indicates that there has been a harmless chemical transformation at the surface of the pipe. A small reduction in impact strength could occur at the discolored surfaces but they are of a very small order and are not enough to cause problems in field installation.

Note: Clear-Guard PVC is not UV resistant and should be covered at all times. Prolonged exposure to UV will cause the pipe to discolor and become less transparent.

Protection – Covering

Discoloration of the pipe can be avoided by shading it from the direct rays of the sun. This can be accomplished by covering the stockpile or the crated pipe with a light colored opaque material such as canvas. If the pipe is covered, always allow for the circulation of air through the pipe to avoid heat buildup in hot summer weather. Make sure that the pipe is not stored close to sources of heat such as boilers, steam lines, engine exhaust outlets, etc.

Protection – Painting

PVC and CPVC pipe and fittings can be easily protected from ultraviolet oxidation by painting with a heavily pigmented, exterior water-based latex paint. The color of the paint is of no particular importance; the pigment merely acts as an ultraviolet screen and prevents sunlight change. White or some other light color is recommended as it helps reduce pipe temperature. The latex paint must be thickly applied as an opaque coating on pipe and fittings that have been well cleaned and very lightly sanded.

Solvent Welding Instructions for PVC & CPVC Pipe & Fittings

Solvent Welding with Primer

GUARDIAN

CLEAR-GUARD

Step 1: Preparation

Assemble proper materials for the job. This includes the appropriate cement, primer and applicator for the size of piping system to be assembled. See both the "Average Number of Joints per Quart" and "Average Number of Joints per US Gallon" tables later in this section for guidelines to estimate the amount of cement required.



Step 2: Cut Pipe

Determine proper carrier and containment pipe lengths to achieve desired center-to-center dimension.

Pipe must be cut as square as possible. (A diagonal cut reduces bonding area in the most effective part of the joint.) Use a handsaw and miter box or a mechanical saw.

Plastic tubing cutters may also be used for cutting plastic pipe; however, some produce a raised bead at the end of the pipe. This bead must be removed with a file or reamer, as it will wipe the cement away when pipe is inserted into the fitting.

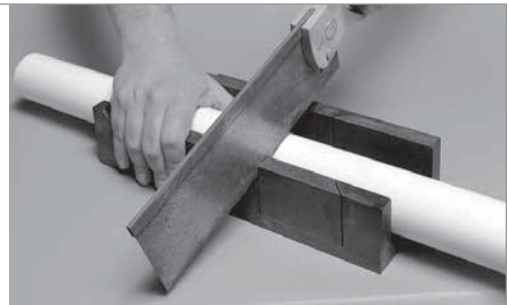

Step 3: Deburr Pipe Ends

Use a knife, plastic pipe deburring tool, or file to remove burrs from the end of small diameter pipe. Be sure to remove all burrs from around the inside as well as the outside of the pipe. A slight chamfer (bevel) of about 15° should be added to the end to permit easier insertion of the pipe into the fitting. Failure to chamfer the edge of the pipe may remove cement from the fitting socket, causing the joint to leak. For pressure pipe systems of 2" and above, the pipe must be end-treated with a 15° chamfer cut to a depth of approximately 3/32" (2.5mm).

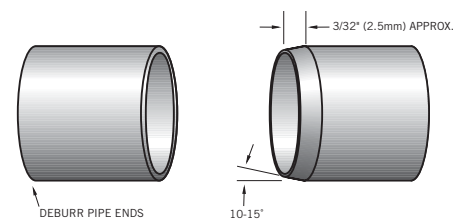

Step 4: Clean Pipe Ends

Remove all dirt, grease and moisture. A thorough wipe with a clean dry rag is usually sufficient. (Moisture will retard cure, dirt or grease can prevent adhesion).



Step 5: Check Fit

Check pipe and fittings for dry fit before welding together. For proper interference fit, the pipe must go easily into the fitting one quarter to three quarters of the way. Too tight a fit is not desirable; you must be able to fully bottom the pipe in the socket during assembly. If the pipe and fittings are not out of round, a satisfactory joint can be made if there is a "net" fit, that is, the pipe bottoms in the fitting socket with no interference, without slop.

All pipe and fittings must conform to ASTM and other recognized standards.

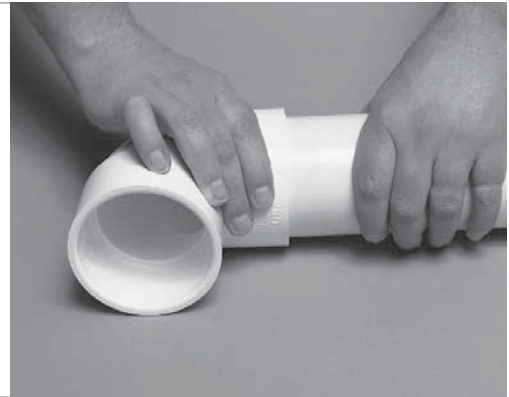

GUARDIAN

CLEAR-GUARD

Step 6: Select Applicator

Ensure that the right applicator is being used for the size of pipe or fittings being joined for both the carrier and containment pipes. The applicator size should be equal to half the pipe diameter. It is important that a proper size applicator be used to help ensure that sufficient layers of cement and primer are applied. It may be necessary to have two separate applicators for the carrier and containment pipe.



Step 7: Priming

The purpose of a primer is to penetrate and soften pipe surfaces so that they can fuse together. The proper use of a primer provides assurance that the surfaces are prepared for fusion.

Check the penetration or softening on a piece of scrap before you start the installation or if the weather changes during the day. Using a knife or other sharp object, drag the edge over the coated surface. Proper penetration has been made if you can scratch or scrape a few thousandths of an inch of the primed surfaces away.



Weather conditions can affect priming and welding action, so be aware of the following:

- repeated applications to either or both surfaces may be necessary
- in cold weather, more time may be required for proper penetration
- in hot weather, penetration time may be shortened due to rapid evaporation

Step 8: Primer Application

Using the correct applicator, aggressively work the primer into the fitting socket, keeping the surface and applicator wet until the surface has been softened. More applications may be needed for hard surfaces and cold weather conditions. Re-dip the applicator in primer as required. When the surface is primed, remove any puddles of primer from the socket.

**Step 9: Primer Application**

Pull carrier pipe out of containment to allow for sufficient clearance. Next, aggressively work the primer on to the end of the carrier pipe to a point 1/2" beyond the depth of the fitting socket.

Immediately and while the surfaces are still wet, apply the appropriate cement.

**Step 10: Cement Application**

Stir the cement or shake can before using. Using the correct size applicator, aggressively work a full even layer of cement on to the pipe end equal to the depth of the fitting socket. Do not brush it out to a thin paint type layer, as this will dry within a few seconds.

**Step 11: Cement Application**

Aggressively work a medium layer of cement into the fitting socket.

Avoid puddling the cement in the socket. On bell end pipe do not coat beyond the socket depth or allow cement to run down into the pipe beyond the spigot end.

**Step 12: Cement Application**

Apply a second full, even layer of cement on the pipe.



Step 13: Assembly

Without delay, while the cement is still wet, assemble the pipe and fittings. Use sufficient force to ensure that the pipe bottoms in the fitting socket.

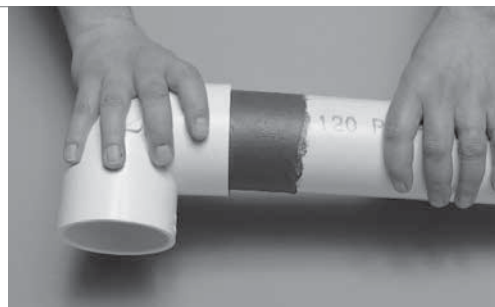

Step 14: Assembly

Hold the pipe and fitting together for approximately 30 seconds to avoid push out.

After assembly, a joint should have a ring or bead of cement completely around the juncture of the pipe and fitting. If voids in this ring are present, sufficient cement was not applied and the joint may be defective.

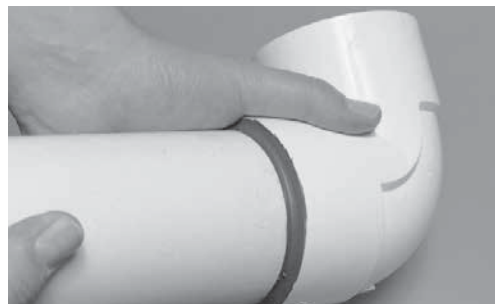

Step 15: Joint Cleaning

Using a rag, remove the excess cement from the pipe and fitting, including the ring or bead, as it will needlessly soften the pipe and fitting and does not add to joint strength. Avoid disturbing or moving the joint.

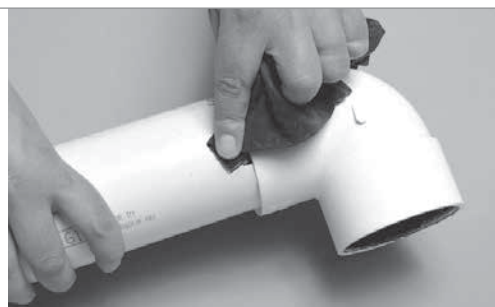

Step 16: Containment Pipe

Immediately repeat steps 8-15 for the containment pipe.

Step 17: Joint Setting & Curing

Handle newly assembled joints carefully until initial set has taken place. Allow curing to take place before pressurizing the system. (Note: in humid weather allow for 50% more curing time.)

For initial set and cure times, refer to both the "Initial Set Schedule" and "Joint Cure Schedule" tables later in this section.

Simultaneous Solvent Welding Instructions

Guardian and Clear-Guard fittings are centralized and locked together; therefore, the carrier and containment can be simultaneously solvent cemented to the pipe when required.

1. Install Centra-Guide support at pipe's end. Distance between the fitting and support should not exceed 5 feet. Install additional supports if required.
2. Determine the extra length of carrier pipe required to accommodate the depth of the fitting. This can be calculated by measuring the carrier socket depth and subtracting it from the containment pipe socket depth.
3. Cut back containment pipe to the required length determined in step 2.
4. Dry fit the fitting to pipe to ensure proper fit and alignment. Mark containment pipe to ensure full insertion during simultaneous solvent cementing.
5. Apply primer to carrier pipe, then carrier fitting, then containment pipe, then containment fitting. (Follow the same procedure from Solvent Welding Instructions above).
6. Apply cement to carrier pipe, then carrier fitting, then containment pipe, then containment fitting. (Follow the same procedure from Solvent Welding Instructions above).
7. Without delay, while the cement is still wet, assemble the pipe and fittings. Use sufficient force to ensure that the pipe bottoms in the socket fitting.
8. Hold the pipe and fitting together for approximately 30 seconds to avoid push out. After assembly, the joint should have a ring or a bead of cement completely around the juncture of the pipe and fitting. If voids in this ring are present, enough cement was not applied, and the joint may be defective.
9. Using a rag, remove the excess cement from the pipe and fitting. Avoid disturbing or moving the joint.

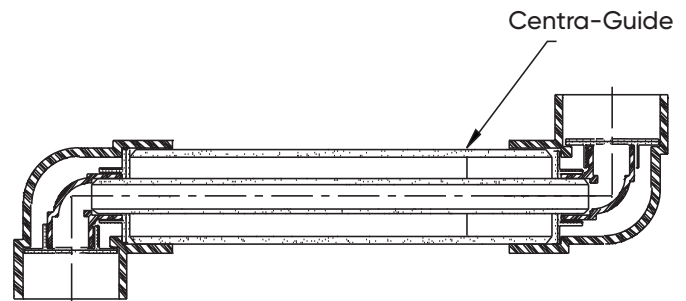
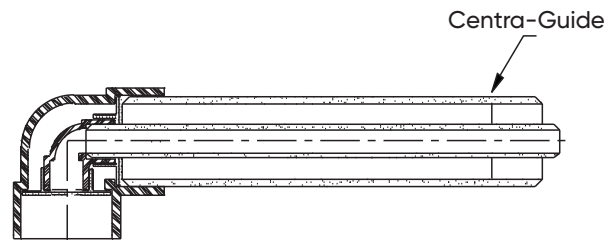
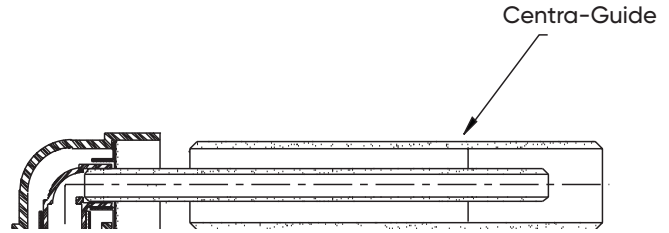

Handle newly assembled joints carefully until the initial set has taken place. Allow curing to take place before pressurizing the system. (Note: in humid weather allow for 50% more curing time). For initial set and cure times, refer to both the "Initial Set Schedule" and "Joint Cure Schedule" tables later in this section.

Joining Large Diameter Pipe and Fittings

As pipe diameter increases so does the difficulty in installing it. For large diameter pipe, the following recommendations apply.

- Select the proper size of applicator. The use of proper size applicators is even more important for large pipe to ensure that enough cement is applied to fill the larger gap that exists between the pipe and fittings.
- Ensure the proper selection of cement and primer (refer to your supplier of cements and primers).
- The size of the joining crew should be increased
 - 6" – 8" pipe: 2 – 3 people per joint
 - 10" – 24" pipe: 3 – 4 people per joint
- The end of the pipe must be chamfered as per the diagram below.
- The primer and cement should be applied simultaneously to the pipe and fittings.
- Make sure to apply a second full layer of cement to the pipe.
- Because of the short sockets in many large diameter fittings, it is very important to have pipe bottomed into the fitting. It is for this reason that above 6" diameter we recommend the use of a "come-a-long".
- Large diameter pipe and fittings will require longer set and cure times. (In cold weather, a heat blanket may be used to speed up the set and cure times.)
- Prefabricate as many joints as possible.
- If pipe is to be buried, make as many joints as possible above ground, then after the joints have cured, carefully lower the piping system into the trench.

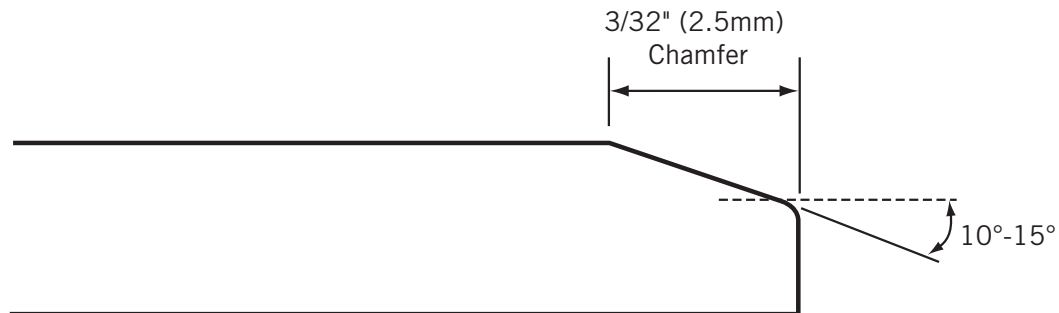

Cold Weather

Although normal installation temperatures are between 40°F (4°C) and 110°F (43°C), high strength joints have been made at temperatures as low as -15°F (-26°C).

In cold weather, solvents penetrate and soften the plastic pipe and fitting surfaces more slowly than in warm weather. In this situation, the plastic is more resistant to solvent attack and it becomes even more important to pre-soften surfaces with an aggressive primer. Be aware that because of slower evaporation, a longer cure time is necessary.

Tips for solvent welding in cold weather:

- Prefabricate as much of the system as is possible in a heated work area.
- Store cements and primers in a warmer area when not in use and make sure they remain fluid.
- Take special care to remove moisture including ice and snow from the surfaces to be joined.
- Ensure that the temperature of the materials to be joined (re: pipe and fittings) is similar.
- Use primer to soften the joining surfaces before applying cement. More than one application may be necessary.
- Allow a longer cure period before the system is used.

Note: A heat blanket may be used to speed up the set and cure times.

Hot Weather

There are many occasions when solvent welding plastic pipe at 95°F (35°C) temperatures and above cannot be avoided. If special precautions are taken, problems can be avoided.

Solvent cements for plastic pipe contain high-strength solvents which evaporate faster at elevated temperatures. This is especially true when there is a hot wind blowing. If the pipe is stored in direct sunlight, the pipe surface temperatures may be 20°F to 30°F (10°C to 15°C) higher than the ambient temperature. In this situation, the plastic is less resistant to attack and the solvents will attack faster and deeper, especially inside a joint. It is therefore very important to avoid puddling the cement inside the fitting socket and to ensure that any excess cement outside the joint is wiped off.

Tips for solvent welding in hot weather:

- Store solvent cements and primers in a cool or shaded area prior to use.
- If possible, store fittings and pipe (or at least the ends) to be solvent welded, in a shady area before welding.
- Try to do the solvent welding in cooler morning hours.
- Cool surfaces to be joined by wiping with a damp rag.
- Make sure that the surface is dry prior to applying solvent cement.
- Make sure that both surfaces to be joined are still wet with cement when putting them together. With large size pipe, more people on the crew may be necessary.
- Using a primer and a heavier, high-viscosity cement will provide a little more working time.

Note: During hot weather, the expansion-contraction factor may increase. Refer to the expansion-contraction design criteria in this manual.

Initial Set Schedule for IPEX Recommended PVC/CPVC Solvent Cements *

Temperature Range (°F)	Temperature Range (°C)	Pipe Size (in)				
		1/2 to 1-1/4	1-1/2 to 2	2-1/2 to 8	10 to 14	>16
60 to 100	16 to 38	2 minutes	5 minutes	30 minutes	2 hours	4 hours
40 to 60	4 to 16	5 minutes	10 minutes	2 hours	8 hours	16 hours
0 to 40	-18 to 4	10 minutes	15 minutes	12 hours	24 hours	48 hours

* The figures in the table are estimates based on laboratory tests for water applications (chemical applications may require different set times). In damp or humid weather allow 50% more set time.

Note 1: Due to the many variables in the field, these figures should be used as a general guideline only.

Note 2: Initial set schedule is the necessary time needed before the joint can be carefully handled.

Joint Cure Schedule for IPEX Recommended PVC/CPVC Solvent Cements *

Temperature Range (°F)	Temperature Range (°C)	Pipe Size (in) & System Operating Pressure							
		1/2 to 1-1/4		1-1/2 to 2		2-1/2 to 8		10 to 14	>16
		<160psi	160 - 370psi	<160psi	160 - 315psi	<160psi	160 - 315psi	<100psi	<100psi
60 to 100	16 to 38	15 min	6 hr	30 min	12 hr	1-1/2hr	24 hr	48 hr	72 hr
40 to 60	4 to 16	20 min	12 hr	45 min	24 hr	4 hr	48 hr	96 hr	6 days
0 to 40	-18 to 4	30 min	48 hr	1 hr	96 hr	72 hr	8 days	8 days	14 days

* The figures in the table are estimates based on laboratory tests for water applications (chemical applications may require different set times). In damp or humid weather allow 50% more cure time (relative humidity over 60%).

Note 1: Due to the many variables in the field, these figures should be used as a general guideline only.

Note 2: Joint cure schedule is the necessary time needed before pressurizing the system.

Average Number of Joints per Quart of IPEX Recommended Cement *

Pipe Size (in)	No. of Joints / Qt.
1/2	300
3/4	200
1	125
1-1/2	90
2	60
3	40
4	30
6	10
8	5
10	2 - 3
12	1 - 2
14	1

Average Number of Joints per US Gallon of IPEX Recommended Cement *

Pipe Size (in)	No. of Joints / Gal.
16	3
18	2
20	1 - 2
24	1

* The figures in this table are estimates based on laboratory tests

Note: Due to the many variables in the field, these figures should be used as a general guideline only.

* The figures in this table are estimates based on laboratory tests

Note: Due to the many variables in the field, these figures should be used as a general guideline only.

Closure Couplings

In some cases, it may be necessary to use closure couplings to seal the containment pipe. IPEX offers vinyl closure couplings in PVC and CPVC.

PVC and CPVC Notes

Guardian vinyl closure coupling installations 3" and up require the following:

- gallon containers of primer and cement
- medium-body, slow-set cement
- large daubers/rollers/brushes

IMPORTANT: Always apply primer and cement liberally. DO NOT take shortcuts. Follow Guardian's instructions explicitly.

Note: Always allow 48 hours or more, depending on environmental conditions, to cure before testing vinyl carrier/containment pipe.

Factory testing of trial joints made by contractor is available at no charge. This is strongly recommended.



Common Mistakes

- Insufficient amount of cement
- Incorrect or outdated cement
- Incorrect or no primer used
- Pipe ends not beveled
- Pipes misaligned
- Contamination (dirt) on cementing area
- Improper positioning of closure coupling on containment pipe
- Pipe window too large
- Movement of pipe sections before cement is fully cured
- Wrong size applicator
- Closure coupling and/or pipe not dry prior to solvent cementing closure coupling

PVC and CPVC Instructions

1. Thermally equalize both the pipe and closure coupling by exposing them to similar temperatures for over 60 minutes. Clean containment pipe with a clean cloth prior to sliding closure coupling onto pipe with minimum resistance. If coupling does not respond accordingly, contact factory. Wrap the coupling with a waterproof plastic bag, or wrap with tape while on containment pipe to keep it clean and dry prior to solvent cementing.

Note: Always use an approved primer and a "medium body – slow set" cement for all cementing procedures on PVC. Check expiration date on cement. If cement exceeds the date, throw away and use cement by expiry date.

2. Bevel all ends of pipe. Slide the closure coupling across the pipe window to check for proper alignment. If resistance is met when transitioning from one side to the other, reposition containment pipe to eliminate resistance.

Warning: All closure coupling installations require two people

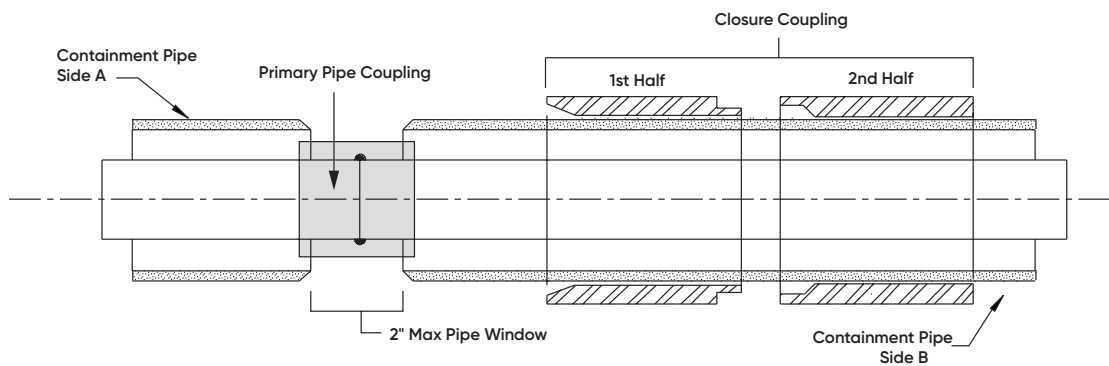

3. Liberally apply primer to 'Side A' of containment pipe as indicated above. Quickly slide the first half of the closure coupling onto the pipe (rotating constantly). Slide closure coupling back to Side B. Do not stop rotating. Apply more primer to Side A and repeat. Perform the same procedure with solvent cement and position first half on Side A as shown below.

Note: Restrain the first half of closure coupling so it doesn't move from its position while cementing the second half of the closure coupling.

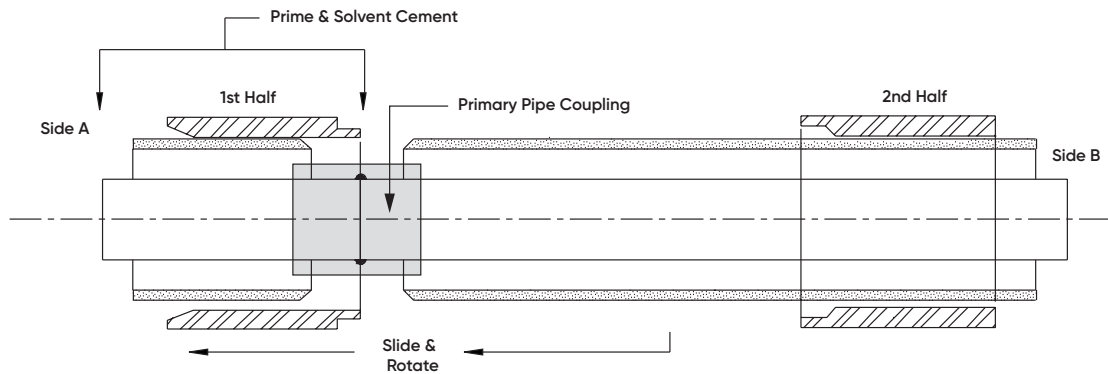

- Repeat the previous step with the second half of the closure coupling on Side B and place into position as shown below. Apply primer to the male portion of the 1st half of the coupling, as well as the containment pipe side.

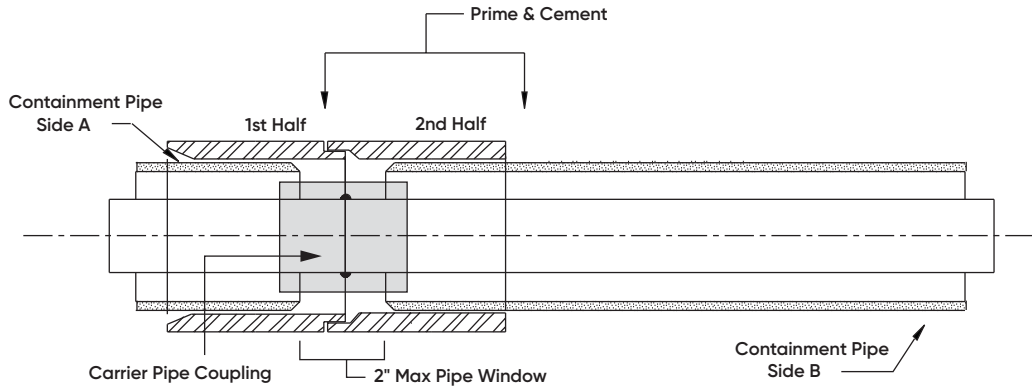

Termination Fittings

Guardian Termination Fittings

Termination fittings represent the beginning and the end of a double-contained piping system. They are used to fully seal the end of the containment pipe while allowing the carrier pipe to continue (if desired). PVC and CPVC termination fittings are supplied as one-piece fabricated fittings. Follow the simultaneous solvent cement recommended procedure for installation.

The fitting can be ordered with taps to allow for venting, draining, etc.

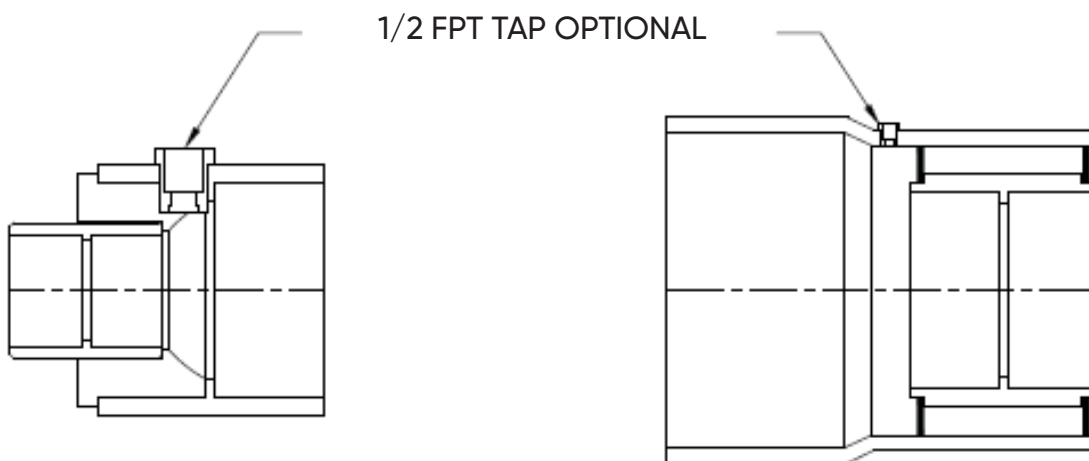

Testing

Carrier Pipe – Site Pressure Testing

The purpose of an onsite pressure test is to establish that the installed section of line, and in particular all joints and fittings, will withstand the design working pressure, plus a safety margin, without loss of pressure or fluid.

Generally a test pressure of 1-1/2 times the safe working pressure for the pipe installed is adequate (without exceeding the maximum pressure rating of the pipe). Whenever possible, it is recommended that hydrostatic testing be carried out. It is suggested that the following hydrostatic test procedure be followed after the solvent-welded joints have been allowed to cure for a minimum period of 24 hours at 73°F (23°C) (timed from the cure of last joint). For more detail, refer to the "Joint Cure Schedule" Table shown previously in the Installation section.

Hydrostatic Test Procedure

1. Fully inspect the installed piping for evidence of mechanical abuse and/or dry suspect joints.
2. Split the system into convenient test sections not exceeding 1,000 ft.
3. Slowly fill the pipe section with water, preferably at a velocity of 1.0 fps or less. Any entrapped air should be evacuated by venting from the high points. Do not pressurize at this stage.
4. Leave the section for at least 1 hour to allow equilibrium temperature to be achieved.
5. Check the system for leaks. If clear, check for and remove any remaining air and increase pressure up to 50 psi. Do not pressurize further at this stage.
6. Leave the section pressurized for 10 minutes. If the pressure decays, inspect for leaks. If the pressure remains constant, slowly increase the hydrostatic pressure to 1 1/2 times the nominal working pressure (without exceeding the maximum pressure rating of the pipe).
7. Leave the section pressurized for a period not exceeding 1 hour. During this time, the pressure should not change.

If there is a significant drop in static pressure or extended times are required to achieve pressure, either joint leakage has occurred or air remains in the line. Inspect for leakage and if none is apparent, reduce the pressure and check for trapped air. This must be removed before further testing.

Any joint leaks should be repaired and allowed to cure fully before re-pressurizing for a minimum of 24 hours.



WARNING



- **NEVER** use compressed air or gas in PVC/CPVC/PP/PVDF pipe and fittings.
- **NEVER** test PVC/CPVC/PP/PVDF pipe and fittings with compressed air or gas, or air-over-water boosters.
- **ONLY** use PVC/CPVC/PP/PVDF pipe for water and approved chemicals.

Use of compressed air or gas in PVC/CPVC/PP/PVDF pipe and fittings can result in explosive failures and cause severe injury or death.

Containment Pipe – Air Testing

After successfully completing the carrier pipe hydrostatic pressure joint integrity test, the containment pipe can be joined and tested.

For systems containing: cable leak detection, low points not easily drained, P-traps, or where it is not possible to dry out the interstitial space, it may be necessary to conduct a pneumatic joint integrity test; subject to the engineer and/or authority having jurisdiction. This alternative joint integrity test uses dry, low-pressure air.

1. Slowly pressurize the containment pipe with air to a MAXIMUM of 5 psi for 1 hour. To ensure that the pressure does not exceed 5 psi, the testing equipment should also include a pressure regulator or pressure relief valve (set at no higher than 5 psi) and a pressure gauge. The system should be partially backfilled so that only joints are exposed.
2. While taking great care not to impact or damage the containment pipe, exposed containment joints should be wiped with an IPEX-approved leak detector. In addition, check the pressure gauge to make sure that there is no pressure decay.
3. It is essential that the system is closely monitored and that the pipe suffers no impact or other damage during the test.

NOTE: For more information on lower pressure air testing of thermoplastic piping systems, reference Unibell B-6.



WARNING

Take special care to avoid causing impact to the piping when testing the interstitial space of rigid thermoplastic systems using compressed gases. Impact to the system during air testing can cause failure which may result in injury or death.

Conduct this test only when the ambient temperature is 50°F or above.

The containment pipe should never be pressurized to any more than 5 psi when using air.

Pipe Repair

Procedure

In the event of a carrier pipe failure, the plant operator should repair the pipe in the following manner:

1. Drain both the carrier and containment piping and then flush through with water to remove any residual chemicals.
2. If the application is below ground, excavate the ground near the pipe leak, taking care not to cause damage in the process. Hand digging is suggested. The ground should be excavated to a depth of at least 6" below the bottom of the pipe.
3. Measure the length of pipe to be removed then cut completely and squarely through the carrier and containment pipe. Remove the leaking section of pipe.
4. Gather four double containment 90° elbow fittings, one double containment pipe (approximately 1.5 times the length of pipe that was removed), and the proper solvent cement/primer.
5. Take one 90° elbow and measure the total depth of the socket of the carrier pipe, then subtract that length from the depth of the containment pipe socket.
6. Mark this measurement on each end of the remaining installed pipe. This is how much extra containment pipe will be removed to create the carrier pipe stub out shown below in Diagram 1.
7. Cut along the marked line of the containment pipe, taking extra care not to cut or nick the carrier pipe.
8. Install the 90° elbow fittings on the ends of the recently cut carrier and containment pipes using the simultaneous solvent welding method.
9. From the new piece of pipe obtained in step 4, cut a piece long enough to attach a fitting on either end. Repeat steps 5, 6, and 7 on both ends of this cut piece of pipe.
10. Join the cut piece of pipe to the already installed fitting using the simultaneous solvent welding method.
11. Repeat steps 9 and 10 on the other installed fitting. Resulting in a setup resembling Diagram 2.
12. Measure the center to center spacing of the carrier pipe stubs sticking out from the joints made in steps 9 to 11.
13. Using the dimensions of the 90° elbows (found in Guardian/Clear-Guard dimensions), subtract 2 times A1 from the center to center spacing. This is the length of the carrier pipe required in the next step.
14. Create a "U-bend" with the remaining new double containment pipe and the two remaining 90° elbows. Use the measurement calculated in step 13 for the length of the carrier pipe. Cut back the containment pipe in the same manner as steps 6 and 7, on both ends of the pipe.
15. Install the 90° elbow fittings on each end of the double containment pipe using the simultaneous solvent welding method. Ensure the 90° elbows are pointing in the same direction, resulting in Diagram 3.
16. Install the "U-bend" onto the pipe stubs from step 11, using the simultaneous solvent welding method, resulting in Diagram 4.

Diagram 1

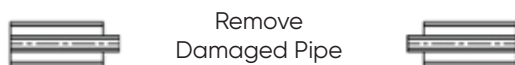

Diagram 2

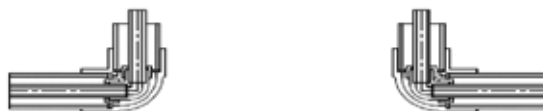

Diagram 3 – U-bend

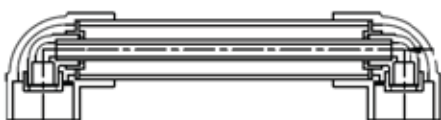
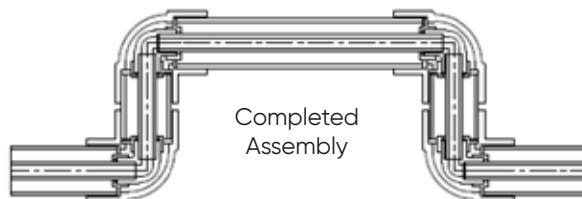

Diagram 4



SECTION FOUR: CUSTOMGUARD®

Overview

Material Selection

Carbon and stainless steel, copper, fiberglass (polyester and vinylester resins), PVDF, PP and dissimilar materials, are all available in CustomGuard® systems. This comprehensive offering, unmatched by any one company, gives IPEX the unique ability to examine just about any double containment requirement and truly offer the best suited, most cost-effective system. While other manufacturers have vested interests in recommending their one and only material/system, IPEX isn't confined by that limitation.

Design

Drawing on more than 30 years of experience in double containment, IPEX has developed a variety of product-specific designs to maximize efficiency and reduce installation costs. As with all our containment systems, our own patented Centra-Guard™ electric low point or continuous cable leak detection systems are also available.



CustomGuard® Dimensions

Steel / Vinyl – Pipe

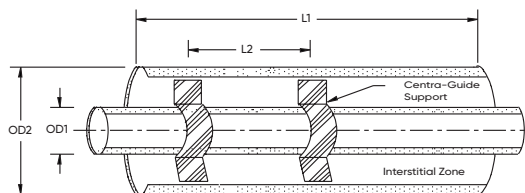

Carrier / Containment (in.)	L1 (ft)	L2 (ft)	OD1 (in.)	OD2 (in.)
1/2 x 2	20	5	0.84	2.38
3/4 x 3	20	5	1.05	3.50
1 x 3	20	5	1.32	3.50
1-1/2 x 4	20	5	1.90	4.50
2 x 4	20	5	2.38	4.50
3 x 6	20	5	3.50	6.62
4 x 8	20	5	4.50	8.62
6 x 10	20	5	6.62	10.75
8 x 12	20	5	8.62	12.75

Steel / Vinyl – 90° Elbow

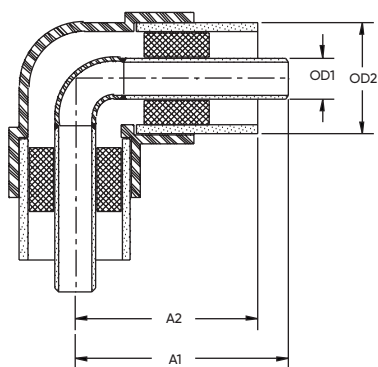

Carrier / Containment (in.)	A1 (in.)	A2 (in.)	OD1 (in.)	OD2 (in.)
1/2 x 2	7.50	6.50	0.84	2.38
3/4 x 3	8.50	7.50	1.05	3.50
1 x 3	8.50	7.50	1.32	3.50
1-1/2 x 4	8.50	7.50	1.90	4.50
2 x 4	9.25	8.25	2.38	4.50
3 x 6	10.50	9.50	3.50	6.63
4 x 8	15.00	14.00	4.50	8.63
6 x 10	18.00	17.00	6.63	10.75
8 x 12	21.70	20.70	8.63	12.75

Steel / Vinyl – 45° Elbow

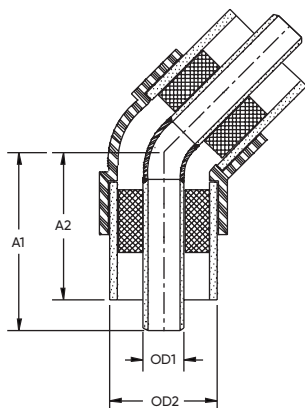

Carrier / Containment (in.)	A1 (in.)	A2 (in.)	OD1 (in.)	OD2 (in.)
1/2 x 2	8.50	7.50	0.84	2.38
3/4 x 3	8.50	7.50	1.05	3.50
1 x 3	8.62	7.62	1.32	3.50
1-1/2 x 4	8.75	7.75	1.90	4.50
2 x 4	9.25	8.25	2.38	4.50
3 x 6	8.75	7.75	3.50	6.63
4 x 8	11.00	10.00	4.50	8.63
6 x 10	15.00	14.00	6.63	10.75
8 x 12	18.94	17.94	8.63	12.75

CustomGuard® Dimensions

Steel / Vinyl – Tee

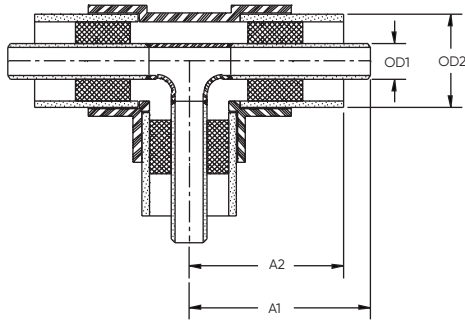

Carrier / Containment (in.)	A1 (in.)	A2 (in.)	OD1 (in.)	OD2 (in.)
1/2 x 2	5.25	4.25	0.84	2.38
3/4 x 3	6.60	5.60	1.05	3.50
1 x 3	6.60	5.60	1.32	3.50
1-1/2 x 4	8.10	7.10	1.90	4.50
2 x 4	8.10	7.10	2.38	4.50
3 x 6	10.50	9.50	3.50	6.63
4 x 8	14.50	13.50	4.50	8.63
6 x 10	17.90	16.90	6.63	10.75
8 x 12	21.70	20.70	8.63	12.75

Steel / Steel – Pipe

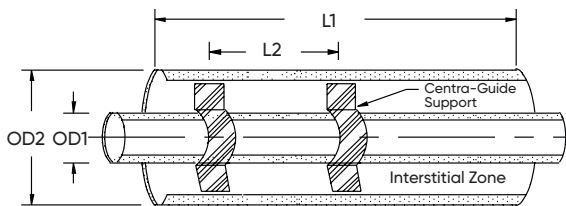

Carrier / Containment (in.)	L1 (ft)	L2 (ft)	OD1 (in.)	OD2 (in.)
1/2 x 2	20	5	0.84	2.38
3/4 x 3	20	5	1.05	3.50
1 x 3	20	5	1.32	3.50
1-1/2 x 4	20	5	1.90	4.50
2 x 4	20	5	2.38	4.50
3 x 6	20	5	3.50	6.62
4 x 8	20	5	4.50	8.62
6 x 10	20	5	6.62	10.75
8 x 12	20	5	8.62	12.75

Steel / Steel – 90° Elbow

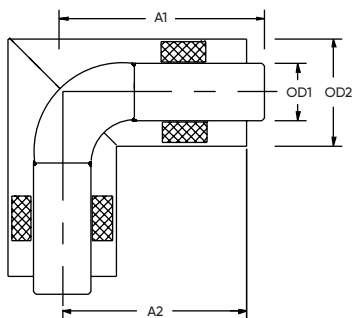

Carrier / Containment (in.)	A1 (in.)	A2 (in.)	OD1 (in.)	OD2 (in.)
1/2 x 2	7.50	6.50	0.84	2.38
3/4 x 3	8.50	7.50	1.05	3.50
1 x 3	8.50	7.50	1.32	3.50
1-1/2 x 4	8.50	7.50	1.90	4.50
2 x 4	9.25	8.25	2.38	4.50
3 x 6	10.75	9.75	3.50	6.63
4 x 8	15.00	14.00	4.50	8.63
6 x 10	17.62	16.63	6.63	10.75
8 x 12	19.00	18.00	8.63	12.75

CustomGuard® Dimensions

Steel / Steel – 45° Elbow

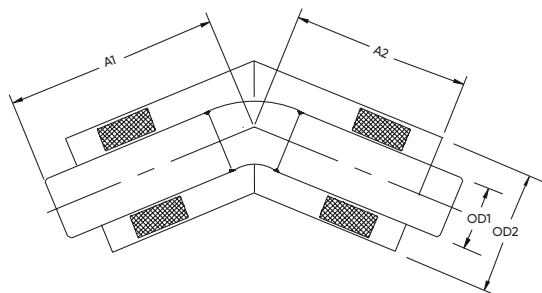

Carrier / Containment (in.)	A1 (in.)	A2 (in.)	OD1 (in.)	OD2 (in.)
1/2 x 2	8.50	7.50	0.84	2.38
3/4 x 3	8.50	7.50	1.05	3.50
1 x 3	8.62	7.62	1.32	3.50
1-1/2 x 4	8.75	7.75	1.90	4.50
2 x 4	9.25	8.25	2.32	4.50
3 x 6	8.75	7.75	3.50	6.63
4 x 8	13.00	12.00	4.50	8.63
6 x 10	18.25	17.25	6.63	10.75
8 x 12	19.50	18.50	8.63	12.75

Steel / Steel – Tee

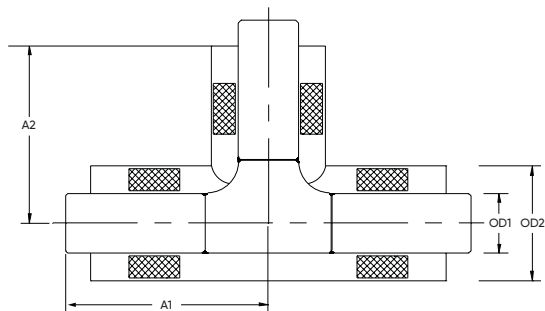

Carrier / Containment (in.)	A1 (in.)	A2 (in.)	OD1 (in.)	OD2 (in.)
1/2 x 2	4.50	3.50	0.84	2.38
3/4 x 3	7.00	6.00	1.05	3.50
1 x 3	6.70	5.70	1.32	3.50
1-1/2 x 4	7.75	6.75	1.90	4.50
2 x 4	7.30	6.30	2.37	4.50
3 x 6	9.63	8.63	3.50	6.63
4 x 8	13.13	12.13	4.50	8.63
6 x 10	17.63	16.63	6.63	10.75
8 x 12	19.00	18.00	8.63	12.75

Steel / FRP – Pipe

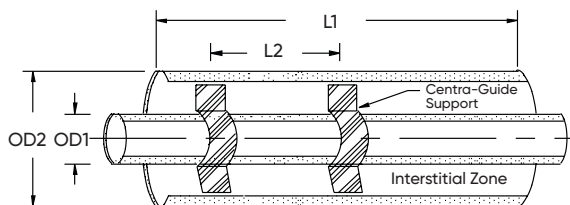

Carrier / Containment (in.)	L1 (in.)	L2 (in.)	OD1 (in.)	OD2 (in.)
1/2 x 2	20	5	0.84	2.38
3/4 x 3	20	5	1.05	3.50
1 x 3	20	5	1.32	3.50
1-1/2 x 4	20	5	1.90	4.50
2 x 4	20	5	2.38	4.50
3 x 6	20	5	3.50	6.62
4 x 8	20	5	4.50	8.62
6 x 10	20	5	6.62	10.75
8 x 12	20	5	8.62	12.75

CustomGuard® Dimensions

Steel / FRP – 90° Elbow

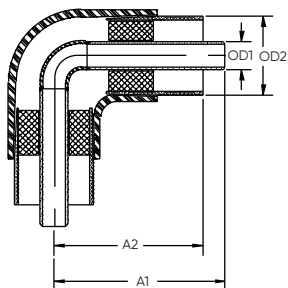

Carrier / Containment (in.)	A1 (in.)	A2 (in.)	OD1 (in.)	OD2 (in.)
1/2 x 2	7.50	6.50	0.84	2.38
3/4 x 3	8.50	7.50	1.05	3.50
1 x 3	8.50	7.50	1.32	3.50
1-1/2 x 4	8.50	7.50	1.90	4.50
2 x 4	9.25	8.25	2.38	4.50
3 x 6	11.50	10.50	3.50	6.63
4 x 8	15.00	14.00	4.50	8.63
6 x 10	17.63	16.63	6.63	10.75
8 x 12	19.00	18.00	8.63	12.75

Steel / FRP – 45° Elbow

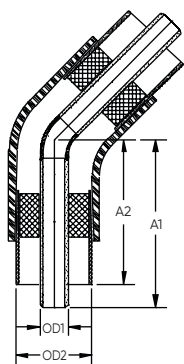

Carrier / Containment (in.)	A1 (in.)	A2 (in.)	OD1 (in.)	OD2 (in.)
1/2 x 2	8.50	7.50	0.84	2.38
3/4 x 3	8.50	7.50	1.05	3.50
1 x 3	8.62	7.62	1.32	3.50
1-1/2 x 4	8.75	7.75	1.90	4.50
2 x 4	9.25	8.25	2.38	4.50
3 x 6	8.75	7.75	3.50	6.63
4 x 8	13.00	12.00	4.50	8.63
6 x 10	18.25	17.25	6.63	10.75
8 x 12	19.50	18.50	8.63	12.75

Steel / FRP – Tee

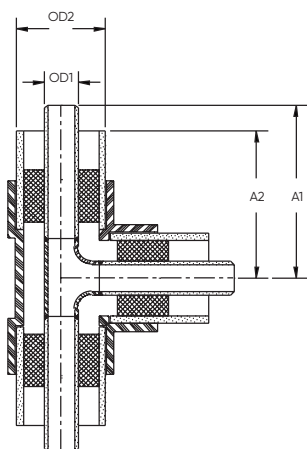

Carrier / Containment (in.)	A1 (in.)	A2 (in.)	OD1 (in.)	OD2 (in.)
1/2 x 2	7.00	6.00	0.84	2.38
3/4 x 3	7.38	6.32	1.05	3.50
1 x 3	7.75	6.75	1.32	3.50
1-1/2 x 4	9.25	8.25	1.90	4.50
2 x 4	9.00	8.00	2.38	4.50
3 x 6	11.50	10.50	3.50	6.63
4 x 8	13.13	12.13	4.50	8.63
6 x 10	17.63	16.63	6.63	10.75
8 x 12	19.00	18.00	8.63	12.75

CUSTOM
GUARD

CustomGuard® Dimensions

Two Piece PVC Closure Coupling – Schedule 40

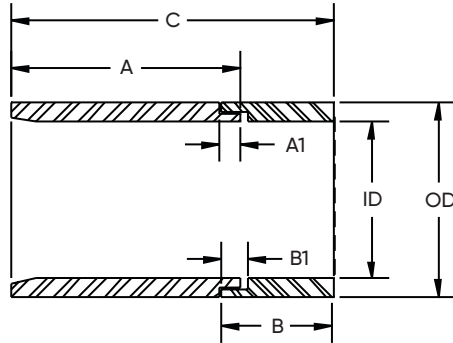

Containment (in.)	A (in.)	A1 (in.)	B (in.)	B1 (in.)	C (in.)	ID (in.)	OD (in.)
2	4.30	1.00	2.40	1.00	6.75	2.37	2.72
3	8.00	2.00	4.00	2.00	10.00	3.50	4.00
4	8.00	2.00	4.70	2.00	11.00	4.50	5.05
6	7.25	2.00	3.50	2.00	9.00	6.63	7.37
8	9.25	2.00	4.50	2.00	12.00	8.63	9.81
10	11.20	2.00	5.20	2.00	14.50	10.75	11.50
12	14.00	2.00	7.00	2.00	19.50	12.75	13.62

CustomGuard® Dimensions

Two Piece PVC / CPVC Closure Coupling – Schedule 80

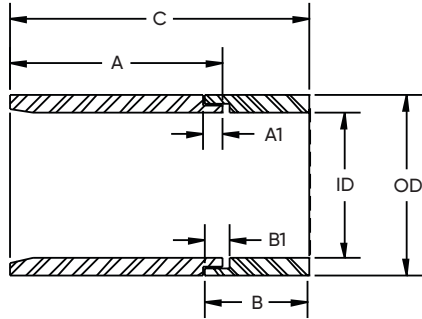

Containment (in.)	A (in.)	A1 (in.)	B (in.)	B1 (in.)	C (in.)	ID (in.)	OD (in.)
2	3.25	1.00	3.25	1.00	5.75	2.37	2.89
3	4.00	1.00	4.00	1.00	7.00	3.50	4.17
4	4.75	2.00	4.75	2.00	8.00	4.50	5.23
6	6.50	1.50	3.00	1.50	8.00	6.63	8.00
8	9.25	1.50	4.50	1.50	12.50	8.63	10.12
10	12.00	2.00	6.00	2.00	14.00	10.75	11.87
12	14.00	2.00	7.00	2.00	19.50	12.75	14.12

Carbon Steel – Closure Coupling

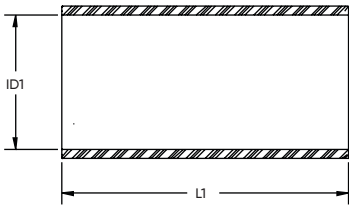

Containment (in.)	L1 (in.)	ID1 (in.)
2	6	2.50
3	6	3.62
4	6	4.62
6	6	6.75
8	6	8.75
10	6	10.87
12	6	12.87

CustomGuard® Dimensions

FRP – Closure Coupling

2" – 6"



Apply adhesive to cut ends of pipe
Square-cut pipe ends (not tapered)

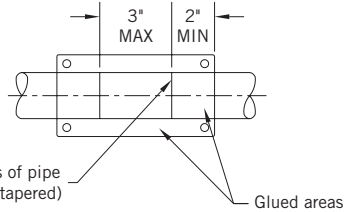

8" – 12"

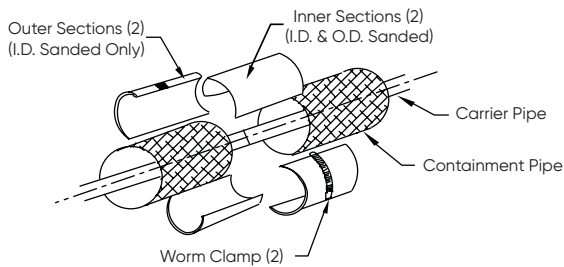

Adhesive Requirement Chart (5 oz. kits)

Pipe Size (in.)	Adhesive Required
2	1/2
3	1/2
4	1
6	2
8	2
10	3
12	3

2" – 6" Kit contains:

- 2 – 180° halves
- 4 bolts and nuts
- 1 required epoxy kit

8" – 12" Kit contains:

- 2 inner 180° FRP shells / I.D. & O.D. de-glossed
- 2 outer 180° FRP shells I.D. de-glossed
- 2 worm clamps
- 1 epoxy resin/hardener bonding kit
- 2 mixing sticks, gloves, sand paper and a brush

Pipe / Fitting Support, Centra-Guide™

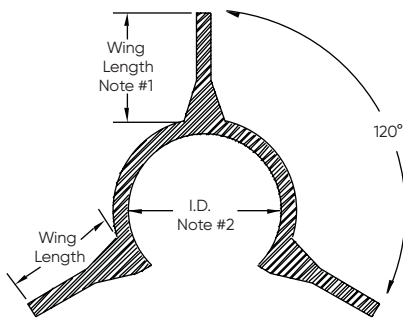

Size (in.)	Stock (in.)	I.D.#2 (in.)	Wing Length (in.)	Part #
1/2	0.19	0.83	1.75	728007
3/4	0.19	1.04	1.75	728008
1	0.25	1.30	1.25	728009
1-1/2	0.25	1.89	1.10	728011
2	0.25	2.36	2.13	728012
3	0.38	3.49	1.50	728014
4	0.38	4.49	1.75	728016
6	0.50	6.61	1.75	728018
8	0.50	8.61	1.75	728019
10	0.75	10.70	2.00	728020

General Notes:

1. Length is sized to fit bore of containment pipe.
2. I.D. sized to provide non-slip against carrier pipe.
Clip is approx. 2" wide.

CustomGuard® Installation Procedures

Basic Principles

Metal/Vinyl, Metal/FRP

This is an example of a metal carrier and vinyl containment 90-degree elbow being joined to its mating pipes. Fitting is supplied with metal pipe beveled for welding and spigot containment ends. First, weld all the metal carrier joints. Fittings will come with the carrier pipe stubbed out. Ensure the vinyl or FRP containment pipe is protected from metal welding (wrap with a wet cloth). When joining pipe sections or pipe to fittings, it is important to slip a closure coupling onto the containment pipe before welding the carrier pipe.

Note: To close FRP window, see FRP closure coupling instructions.

Typical Socket Weld

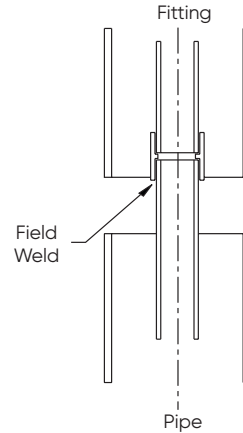

WARNING

Flammable vapors may be present in the space between the carrier pipe and containment pipe. Use caution when an open flame is present or when welding.

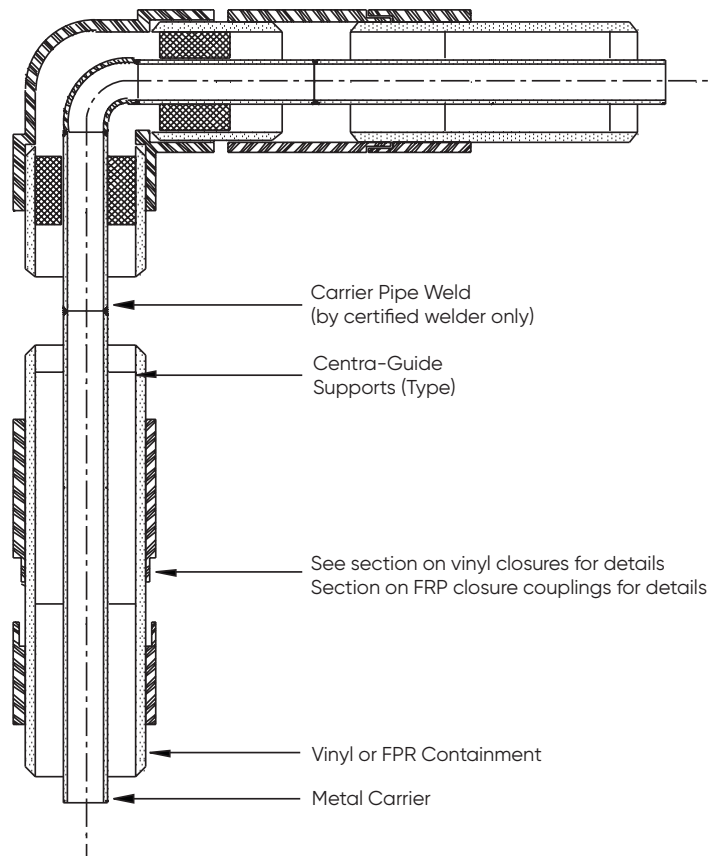

Metal/Metal Installation

Double containment installations of this kind always require staggered assembly. First weld all the carrier joints. Leave a window (gap) between the containment pipe ends, to be closed with a closure coupling later. One advantage of this method is the ability to test and inspect all carrier pipe joints before closing the containment pipe sections. Pipe and fittings are supplied with spigot ends on all outlets. All fittings are supplied with the carrier nipple or socket extending beyond the end of the containment pipe. Carrier pipe nipples are supplied with beveled ends.

When joining pipe sections or pipe to fittings, it is important to slip a closure coupling onto the containment pipe before you weld the carrier pipe. A window will be created by proper back cutting of the containment pipe. Every carrier pipe weld will have its own closure coupling to seal the containment pipe window. Window lengths will vary depending on the length of the closure coupling. Proper window length will allow for a minimum one-inch overlap of closure coupling on both sides of containment pipe.

After the carrier pipe system has been fitted, welded, tested and accepted, the closure couplings are then installed over the window to seal the containment piping. Position the coupling over the pipe window (centerline of the coupling should meet the centerline of the pipe window). Weld the closure coupling to the containment pipe (per welding specifications). Test containment as per IPEX testing instructions.

Metal/Vinyl Installation

Similarly to metal/metal installation, metal/vinyl installations require staggered assembly. The carrier pipe joints will all be welded first. During this welding, the installer must take special care to not damage the containment (vinyl) pipe. This can be done by wrapping a wet rag or towel into the interstitial space of the fitting, ensuring no sparks or slag come in contact with the thermoplastic components. A window (gap) needs to be left between the containment pipe ends that will later be closed with a closure coupling. This closure coupling will also be slipped onto the containment pipe before all the carrier pipe joints are welded. All fittings are supplied with the carrier nipple or socket extending beyond the end of the containment pipe.

After the carrier pipe system has been fitted, welded, tested and accepted, the closure couplings are then installed over the window to seal the containment piping. These closure couplings will be installed with solvent welding. Follow the steps from the Guardian closure couplings installation instructions for PVC and CPVC. Finally, test using the containment pipe testing from the Guardian section.

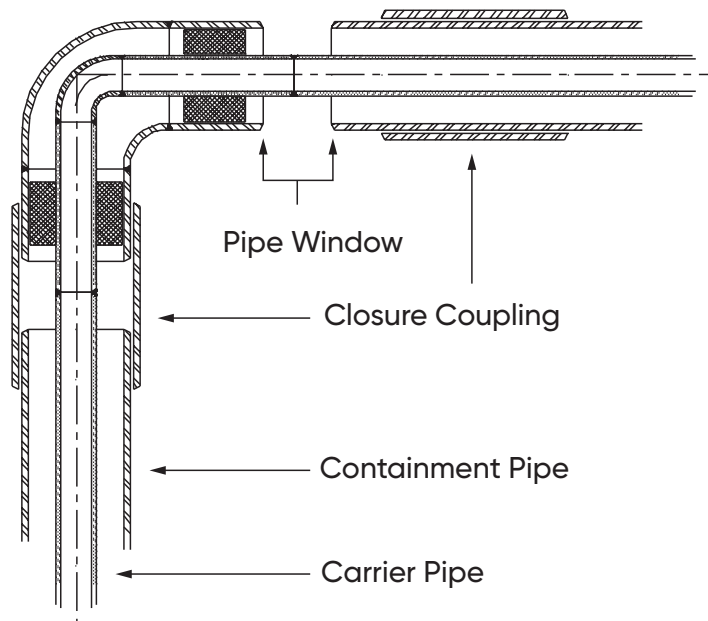

FRP Closure Coupling Installation

Adhesive Requirement Chart (5 oz. kits)

Pipe Size (in)	Adhesive Required
2	1/2
3	1/2
4	1
6	2
8	2
10	3
12	3

2", 3", 4" & 6" kit contains:

- 2 180° shells
- 4 sets nuts / bolts
- 1 epoxy resin/hardener kit
- 2 mixing sticks, gloves, sandpaper & brush

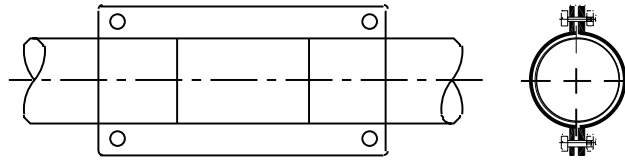

8" – 12" kit contains:

- 2 inner 180° FRP shells / I.D. & O.D. de-glossed
- 2 outer 180° FRP shells / I.D. de-glossed
- 2 worm clamps
- 1 epoxy resin/hardener bonding kit
- 2 mixing sticks, gloves, sandpaper & brush

FRP Closure Coupling Installation Instructions

1. Center the inner FRP shells over the containment pipe window. Mark the pipe at each end of the shells. Using a sander with 40-grit belt, sand (de-gloss only) the overlay area of the containment pipe beyond your marks.
2. Again, place the inner FRP shells over the pipe window. Examine and fit, as necessary, the mating edge of the shells to provide a 1/8 inch maximum gap between mating edge (one side only). Remove after proper fit is verified.
3. Using sandpaper, lightly finish sanding all shell bonding surfaces, then brush any dust from all shell and pipe surfaces to be bonded. Install a loose worm clamp outside each pipe mark.
4. Following the mixing instructions furnished with your kit, mix the hardener and resin until a consistent color is achieved. Pot life allows for a 15 to 20 minute working cycle.
5. Apply a thin, even coat of mixed epoxy to the sanded pipe and inner shells. Place the inner shells over the pipe window (center), re-coat the complete O.D. of the two inner shells including seams as well as the two I.D. surfaces of the outer shells. Place the coated outer shells over the coated inner shells ensuring seam overlap occurs.
6. Position the two worm clamps by dividing the closure coupling into thirds evenly and tighten them to provide a thin bond layer between the shells. Spread excess adhesive along all seams and ends of the shells and pipe connections.

General Notes

Epoxy adhesive may require a heat source to enhance curing in cold weather conditions. Please consult factory. If heat blankets are required, refer to cure times shown on adhesive instruction and heating blanket.

Carefully handle FRP parts to avoid contamination. Use new gloves or clean, dry cotton cloths. Protect the bonding surfaces from any moisture; during wet weather, tenting is required.

Metal/Vinyl, Metal/FRP: Style C Termination Fitting

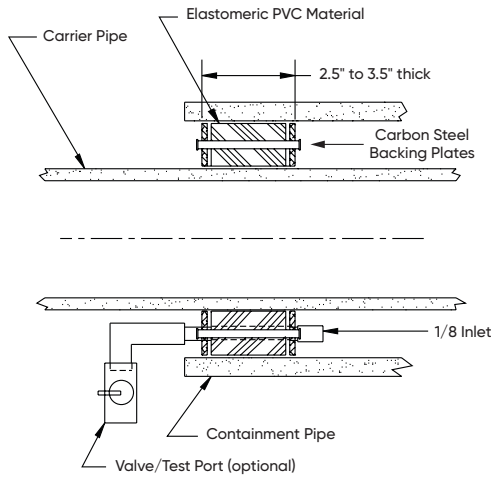

Installation Procedure

All Style C termination fittings are shipped to job site completely assembled and ready for field installation.

Slide the termination fitting over the carrier pipe and into the end of the containment pipe, recessing it approximately one inch from the containment pipe end. As the bolts are tightened, the end plates compress the elastomeric material creating a seal between the carrier and containment pipe.

Tighten all bolts following the torque sequence. When HDPR, polypro, PVDF, and FRP containment pipes are used, installation of a restraining collar is necessary.

NOTE: I.D. and O.D. of termination fitting are sized per specified carrier and containment pipe.

End View

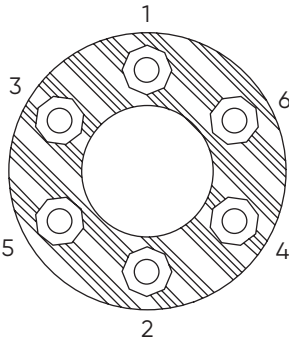

Pipe Size (in.)	No. of Bolts	Bolt Size	Max Torque (ft. lbs)
1 x 3	3	1/4 NC	8
1 x 4	4	1/4 NC	8
1-1/2 x 4	4	1/4 NC	8
2 x 4	4	1/4 NC	8
3 x 6	6	1/4 NC	8
4 x 8	6	5/16 NC	10
6 x 10	6	5/16 NC	10
8 x 12	6	5/16 NC	10

Metal/Metal Butt Weld Termination

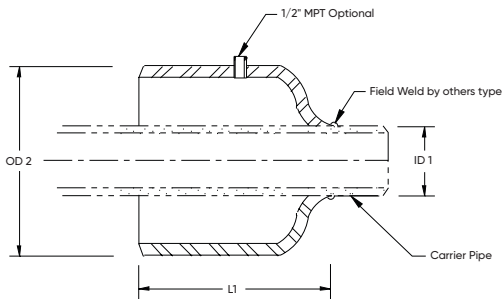

Carrier / Containment (in.)	L1 (in.)	ID1 (in.)	OD2 (in.)
1/2 x 2	3.00	0.89	2.38
1 x 3	3.50	1.37	3.50
1-1/2 x 4	4.00	1.96	4.50
2 x 4	4.00	2.43	4.50
3 x 6	5.50	3.55	6.62
4 x 8	6.00	4.56	8.62
6 x 10	6.00	6.68	10.75
8 x 12	7.00	8.68	12.75

Testing

Carrier Pipe – Site Pressure Testing

The purpose of an onsite pressure test is to establish that the installed section of line, and all joints and fittings, will withstand the design working pressure, plus a safety margin, without loss of pressure or fluid.

Generally, a test pressure of 1-1/2 times the safe working pressure for the pipe installed is adequate (without exceeding the maximum pressure rating of the pipe). Whenever possible, it is recommended that hydrostatic testing be carried out.

Vinyl Containment Pipe – Air Testing

After successfully completing the carrier pipe hydrostatic pressure joint integrity test, the containment pipe can be joined and tested.

For systems containing: cable leak detection, low points not easily drained, P-traps, or where it is not possible to dry out the interstitial space, it may be necessary to conduct a pneumatic joint integrity test; subject to the engineer and/or authority having jurisdiction. This alternative joint integrity test uses dry, low-pressure air.

1. Slowly pressurize the containment pipe with air to a MAXIMUM of 5 psi for 1 hour. To ensure that the pressure does not exceed 5 psi, the testing equipment should also include a pressure regulator or pressure relief valve (set at no higher than 5 psi) and pressure gauge. The system should be partially backfilled so that only joints are exposed.
2. While taking great care not to impact or damage the containment pipe, exposed containment joints should be wiped with an IPEX-approved leak detector. In addition, check the pressure gauge to make sure that there is no pressure decay.
3. It is essential that the system is closely monitored and that the pipe suffers no impact or other damage during the test.

NOTE: For more information on lower pressure air testing of thermoplastic piping systems, reference Unibell B-6.

Metal Containment Pipe Testing

Metal containment pipe installations can be tested using IPEX's test fitting. This test fitting is designed to seal the interstitial space and provide a pressurization port for testing purposes. When permanently installed, it acts as a termination fitting with a drain valve. It is also used temporarily to test containment joints in subassemblies before joining to your next subassembly. Follow proper metal pipe testing practices to properly test the metal piping. Once a successful pressure test is completed, the fitting can be removed and used again. Contact IPEX for more information.



WARNING

Take special care to avoid causing impact to the piping when testing the interstitial space of rigid thermoplastic systems using compressed gases. Impact to the system during air testing can cause failure which may result in injury or death.

Conduct this test only when the ambient temperature is 50°F or above.

The containment pipe should never be pressurized to any more than 5 psi when using air.

NOTES

SECTION FIVE: LEAK DETECTION

Electronic leak detection offers a solution for continuously monitoring a double contained piping system. It will detect a leak in the carrier pipe and alert personnel immediately. Electronic leak detection should always be installed in conjunction with visual leak detection so that alarms can be verified by personnel before corrective measures are taken. The two most common forms of electronic leak detection are Low Point and Continuous Cable. Both systems offer constant monitoring and add to the failsafe design of a double contained piping system.



Centra-Guard™ Electronic Low Point Leak Detection

Application

Centra-Guard™ leak detection systems are well suited to above-ground suspended pipeline applications, with sensors housed on the external wall of the pipe, in a saddle-type clamp. Centra-Guard is also well suited to underground pipeline systems with sensors resting on the external wall of a drip leg assembly. Low point electronic leak detection is ideal for double contained applications that require flexible and cost effective leak detection solutions.

Sensors

To detect the presence of fluid leakage into the interstitial space, leak detection stations are installed inline that allow for leakage to accumulate. Each station segregates that portion of the system into a zone that is monitored by an individual external capacitive sensor affixed to the outside of the leak detection station pipe.

- Sensor LED light
 - Illuminated light indicates the sensor is operational
- Built-in sensitivity control
 - Enables sensing point adjustment to minimize false alarms
- Non-intrusive sensors mean:
 - No need for upsizing containment pipe or pulling cable, reducing material and installation cost
 - No need to remove or replace sensors after a leak
 - No need to verify compatibility with fluids

Electrical Connections

- Capacitive proximity sensor
 - 3-wire, 24 VDC, normally closed solid state switches.
 - Normally closed sensors ensure a failsafe system.
 - Wire break/short or sensor malfunction trigger an alarm
- Sensor power is sourced to the sensors from the control panel.
- Sensor switches open when fluid is detected in the outer containment pipe.

Control Panel

- Internally fused
- Requires 120 VAC and 60 Hz
- Keyed On/Off switch & Alarm Silence switch
- Available 8, 16, 24, 32, 64, 96, 128, 160, and 192 zones
- Each zone is continuously monitored by the processor
- Panel will identify:
 - Date, time, zone and type of alarm (break/short or sensor malfunction)
- Alarm data saved in non volatile memory
 - Data is not lost if there is a power failure
- Standard NEMA 4X FRP enclosure with mounting flange
- Available NEMA 4X: Aluminum, Stainless Steel enclosure
- Built in audible and visual alarm signals
 - 95 dB alarm
 - LCD monitor indicates the type of alarm
 - Large Alarm light
- HMI buttons
 - Allow user to scroll through history, status, and test screens as well as alarm acknowledgment.
- Multi-level password protection ensures only authorized personnel may acknowledge an alarm.
- Standard SPDT general alarm relay switch
 - Allows interaction with plant PLC
- Standard RS-485 communication port
 - Allows for communication with mobile devices/printers
- Optional remote monitoring via phone app, email, or internet browser.



WARNING

Panel requires constant 120VAC 60Hz Power to operate. During power outage panel and sensors are not operational. Personnel are required to ensure that power is being supplied to the panel. The Power Light must be illuminated and the LCD monitor must read "LEAK DETECTION SYSTEM OPERATING NO ALARMS DETECTED". This is the only indication that the panel and wired sensors are operational and monitoring.

NOTE: For additional Operating and Maintenance information including trouble shooting data, please contact IPEX.

8 & 16 Zone Leak Detection Panel

Standard 8 and 16-zone panels

- Failsafe Design has processor and HMI display for detection of fluid by sensor and continuity of wire.
- Standard general alarm SPDT relay contacts allow communication with plant PLC.
- Standard NEMA 4X FRP enclosure.
- Optional NEMA 4X enclosures: aluminum, T304 stainless steel, T316 stainless steel.
- Specially designed panels available upon request.

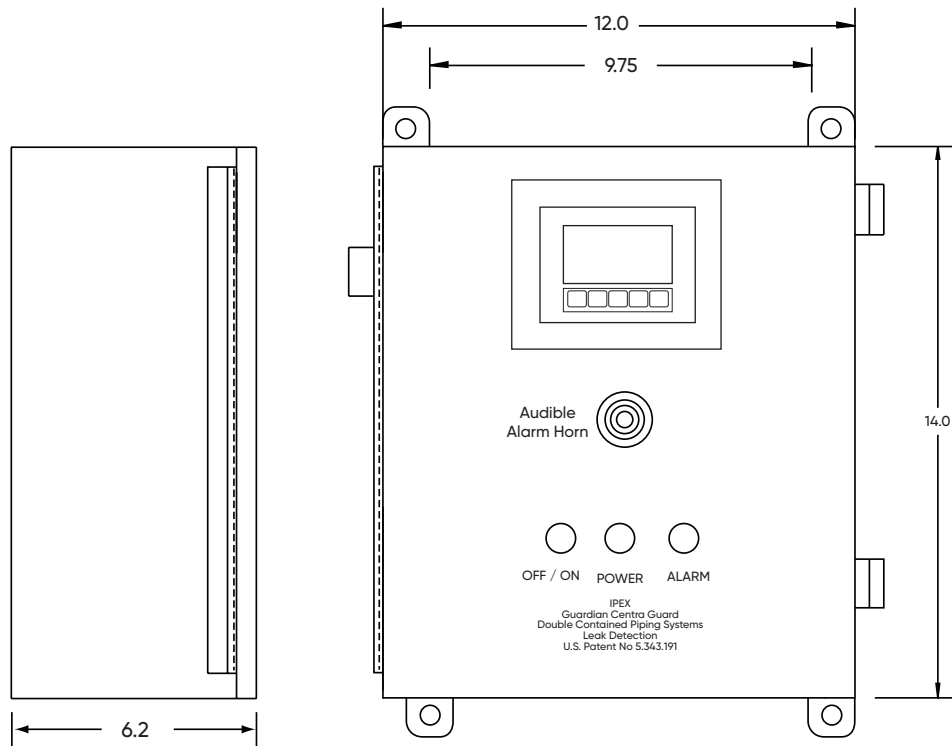

NOTE: Refer to Centra-Guard O & M manual for wiring and startup procedures.

Underground Leak Detection Station with Sensor and Pump Out Port

General Notes

- All fittings are factory tested.
- Leak detection shipped in four separate pieces consisting of: containment tee, saddle, sensor riser, pump out riser and u-bend.
- Containment tee sized per system requirement.
- Leak detection – U.S. patent no. 5,343,191.

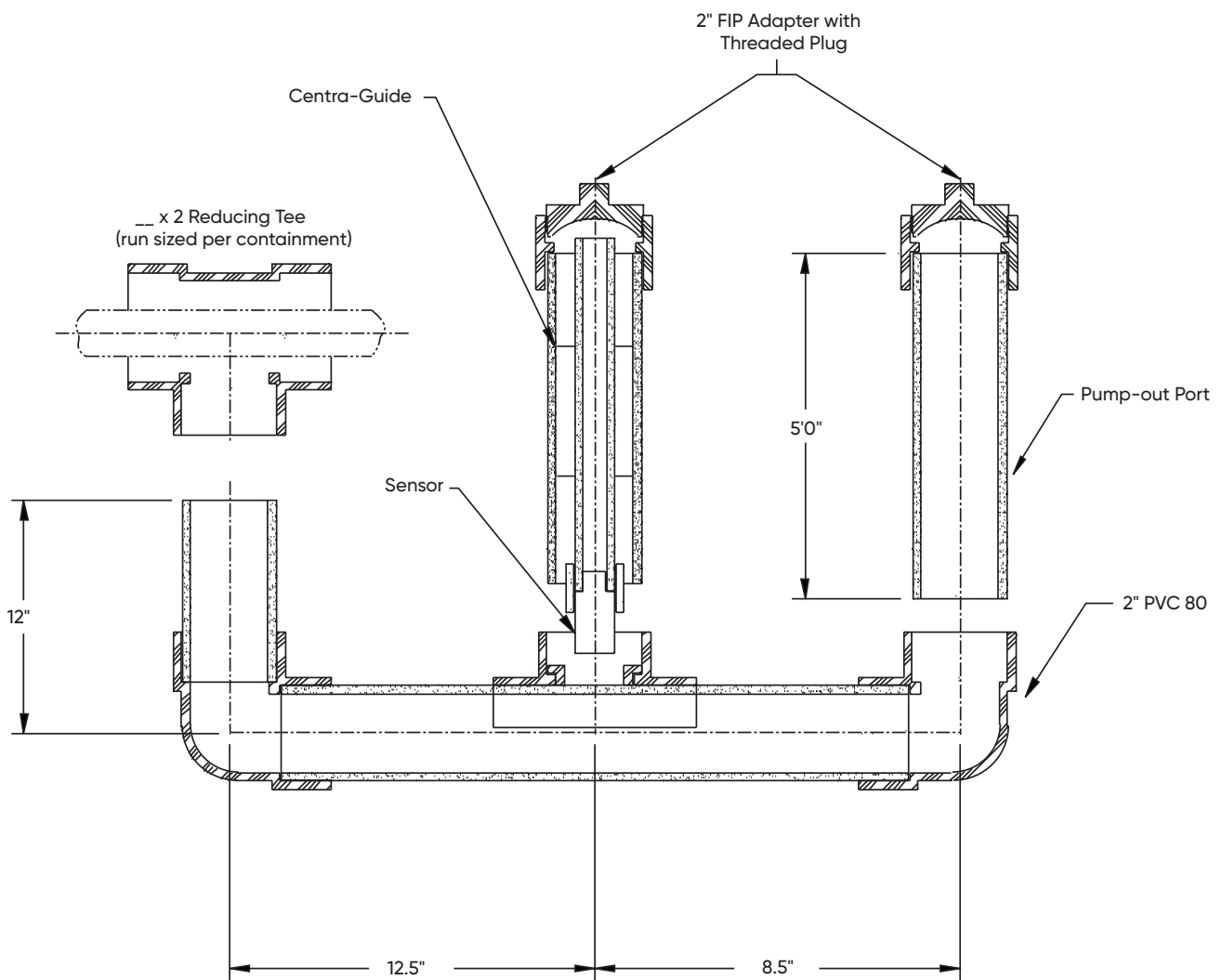

Visual Underground Leak Detection Station

General Notes

- Leak detection shipped in three separate pieces consisting of containment tee, saddle, riser and U-bend.
- Containment tee sized per system requirement.

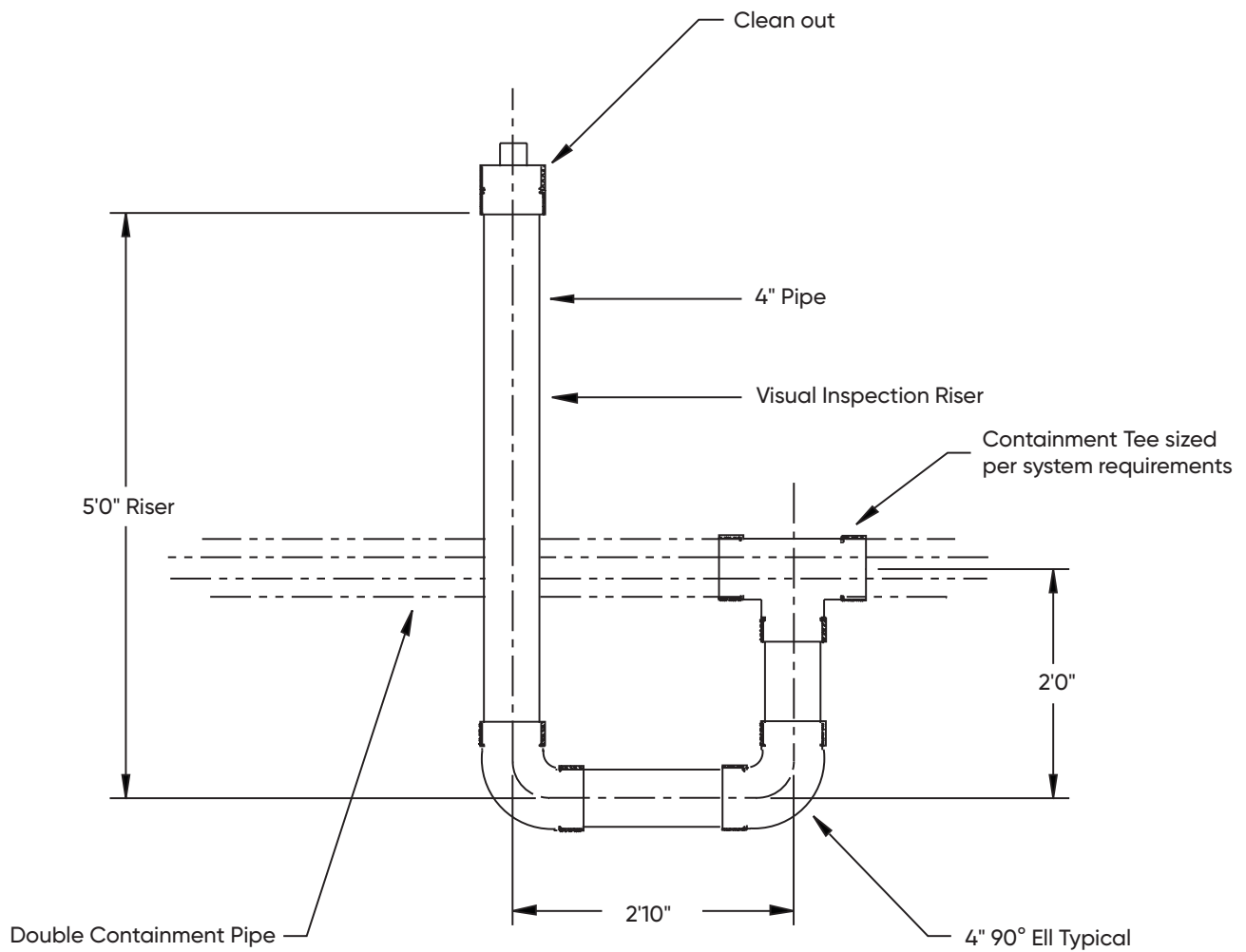

Above-Ground Leak Detection Station With Sensor

General Notes

- All fittings are factory tested.
- All dimensions are in inches unless otherwise indicated.
- Containment tee sized per system requirement.
- Guardian leak detection – U.S. patent no. 5,343,191.

Dimensions

Carrier / Containment (in.)	A (in.)	B (in.)	C (in.)	D (in.)	E (in.)
2 x 4	1.25	19.25	1.50	5.00	5.25
3 x 6	1.88	19.75	2.13	5.00	5.25
4 x 8	2.31	20.40	2.56	5.00	5.25
6 x 10	3.50	21.50	3.75	5.00	5.25
8 x 12	4.56	22.50	4.81	5.00	5.25

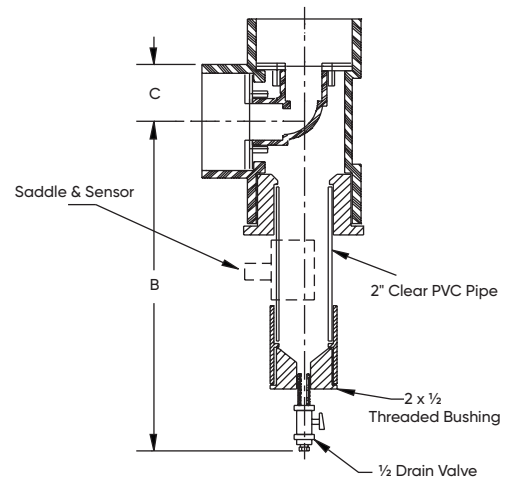
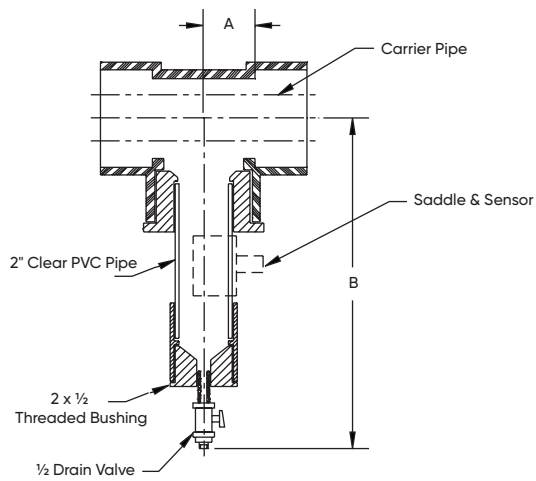
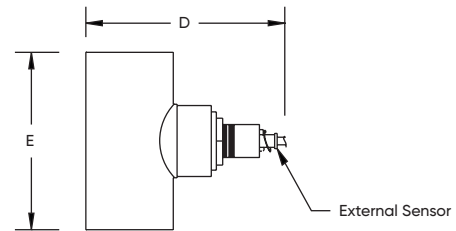

Above-Ground Leak Detection Station

General Notes

- All fittings are factory tested.
- All dimensions are in inches unless otherwise indicated.
- Containment tee sized per system requirement.

Dimensions

Carrier/Containment (in.)	A (in.)	B (in.)	C (in.)	D (in.)	E (in.)
2	1.25	19.25	1.50	5.00	5.25
3	1.88	19.75	2.13	5.00	5.25
4	2.31	20.40	2.56	5.00	5.25
6	3.50	21.50	3.75	5.00	5.25
8	4.56	22.50	4.81	5.00	5.25

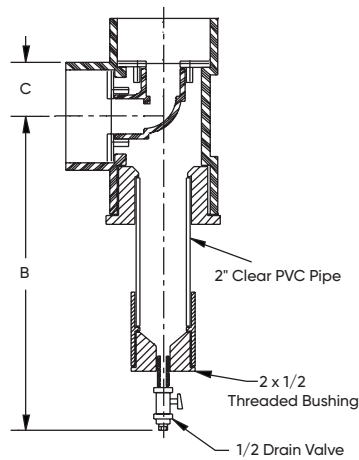
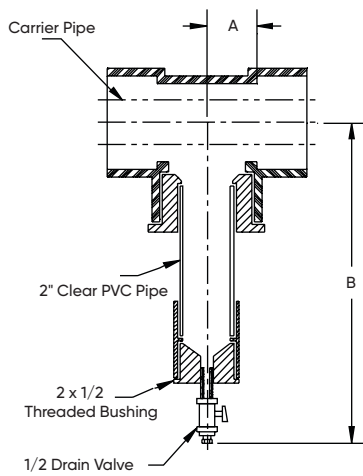

Guardian™ PAL-AT Cable Leak Detection

Introduction

IPEX offers continuous leak detection systems using the Guardian PAL-AT cable leak detection system. This system locates potential problems anywhere along the sensor string and alarms on contact with a liquid. The sensor cables rest on the bottom of the secondary containment piping and is able to detect and locate multiple leaks. IPEX Guardian piping using PAL-AT cable leak detection will be supplied with pre-installed pull rope in the containment pipe. These ropes will be joined during installation to pull the detection cable through the system after testing. Contact IPEX for installation instructions.

Application

Continuous leak detection systems are well suited for underground as well as above ground double contained pipeline systems that require immediate leak detection and leak location accuracy. This allows the end user to immediately locate and repair the leak.

Sensing Cable

The Sensor cable used with the Guardian PAL-AT system is coaxial construction consisting of an insulated copper center conductor, spacer material, and an outer braid. The cable will detect liquids equivalent to a small puddle, approximately 3in in diameter to minimize false alarms that can be caused by condensation. Cable sensitivity is field adjustable allowing the end user to adjust for higher condensation areas.

Control Panel

The Guardian PAL-AT monitoring unit is microprocessor based and capable monitoring up to 2000, 5000, or 7500 ft of cable per sensor string. The unit has a 2-line by 40-character backlit LCD that provides constant system data.

When the system identifies a leak a break or a short, an alarm will sound and the display will clearly indicate the type of fault, i.e. BREAK or SHORT and display the location of the fault.

The monitor uses a 120/240 VAC, 100VA, 50/60 Hz, single phase power source and is equipped with a RS-232 communication port and a minimum of one common and one per cable SPDT output relay rated for 250 VAC, 10 A, allowing for communication with a plant PLC. The monitor case is a modified NEMA 12 enclosure. NEMA 4X outer enclosures are available on special order.

The cable leak detection system is capable of locating the point of origin of the first liquid leak or fault (break/short/probe) within + 0.1% (0.2% for hydrocarbons) of the sensor string length, or +5 feet, whichever is greater. The system can identify the type of alarm (leak/break/short/probe) as well as the location and records significant events in non-volatile memory.

An optional Output Relay System provides 4 to 60 additional alarm relays. Each relay can be assigned to activate if a leak is detected in a specific section of cable. This provides precise control when a single cable string monitors several pipes or sensitive areas.



Guardian PAL-AT Panel

Model Number	Cable Capacity	Maximum Cable Range		Dimensions		Weight lb
		Feet	Meters	In (HxWxD)	mm (HxWxD)	
AT20C	1	2000	600	14x12x7	360x305x180	25
AT50C	1	5000	1500	14x12x7	360x305x180	25
AT40K	8	5000	1500	18x16x7	460x410x180	40
AT20K	2	7500	2300	14x12x7	360x305x180	25
AT80K	8	7500	2300	18x16x7	460x410x180	40

Power:

- AT20C/50C/20K – 120/240 VAC, 50/60 Hz, 50 VA
- AT40K/80K – 120/240 VAC, 50/60Hz, 100 VA

Ambient Operating Range: 0°F to 120°F (-18°C to 50°C)

Alarm Outputs

- Fault Conditions: Leak, Break, Short or Probe Activation
- Distance to Fault Location
- Date and Time of Fault
- Activation of Output Relays
- Red LED Optical Alarm

Guardian PAL-AT AGW-Gold sensor cable

This AGW-Gold cable has the ability to detect both water-based and hydrocarbon liquids. This reduces the number of sensor cables required in many applications. Each of these PAL-AT sensor cables can be dried and reused after a water-based or volatile hydrocarbon leak has been cleaned up. These cables have no exposed metal and are designed for corrosive chemical applications. Each individual strand of braid wire is coated with a high temperature, corrosion resistant polymer and the length of the cable is covered with a fluoropolymer over braid. Because there is no exposed metal, the Gold cables eliminate the need for special isolation precautions in cathodic-protected pipe applications.

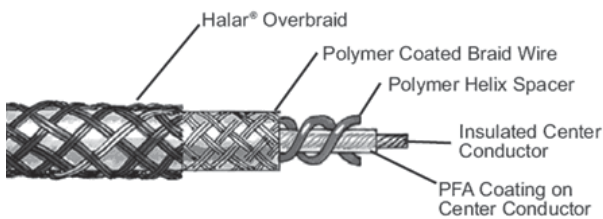

Guardian PAL-AT TFH hydrocarbon sensor cable

This TFH cable uses a hydrocarbon permeable jacket to detect hydrocarbon liquids while ignoring water-based liquids. In some cases, the sensor cable can be dried and reused after a volatile hydrocarbon leak has been cleaned up.

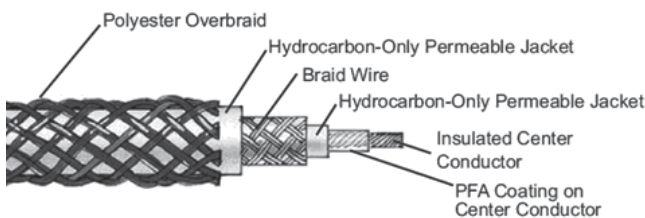

Optional Equipment

NEMA 4X Junction Box

These junction boxes provide a watertight enclosure for connectors. Sizes are available to accommodate several connectors.



SPECIFICATIONS

- Type: NEMA 4X

Model No	Dimensions		Number of Connectors
	in	mm	
JBX6	6x6x4	(150x150x100)	1
JBX8	8x6x4	(200x150x100)	2
JBX10	10x8x4	(250x200x100)	3-4
JBX12	12x10x4	(300x250x100)	5-6

Remote Alarm Indicators

These alarms are recommended for installations where Guardian PAL-AT monitoring units are located in isolated areas. When the monitoring unit is connected by standard 18 gauge, 3 wire cord, the Remote Alarm Indicator may be located up to 1,000 feet away.



SPECIFICATIONS

- Alarm Horn: 75 dB chime
- Alarm Light: High Efficiency LED
- Size: 4.7" W x 3.7" H x 2.0" D (120 mm x 95 mm x 50 mm)
- Power Requirements: None required
- Cable Length: 20 ft (6 m)

Audible Alarm

All Guardian PAL-AT monitoring units may be factory equipped with an Audible Alarm mounted on the front of the monitoring unit.

SPECIFICATIONS

- Material: Black Molded Plastic Case
- Size: 1/4" x 11/8" diameter (6 mm x 30 mm)

Model No	Type	Sound Output @ 2ft
M-SP	Slow Pulse	90dB
M-CA	Chime	75 dB

Pull Points

1. Sensor cable must be "pulled" into the monitored areas using a continuous pull rope free of splices between pull points. Surfaces in which the cable may come in contact with during "pulling" operations must be smooth to prevent hanging up or damaging of the cable.
2. Generally, pull points can be located at 500' intervals for straight runs. Each 90° fitting on the run reduces the interval by 150'. For example, a run of 50' with 3 elbows is allowable ($500' - (3' \times 150') = 50'$).
3. Pull point designs should be selected not only on the basis of accessibility during installation, but potential future cable replacement. When future cable replacement is a consideration, it is recommended that underground installations have watertight junction boxes or containment contained access points installed at grade or in vaults.

Caution: Pulling points often become calibration locations. When this occurs, accessibility to the cable connectors is necessary during the initial commissioning of the alarm panel and the system's setup procedures.

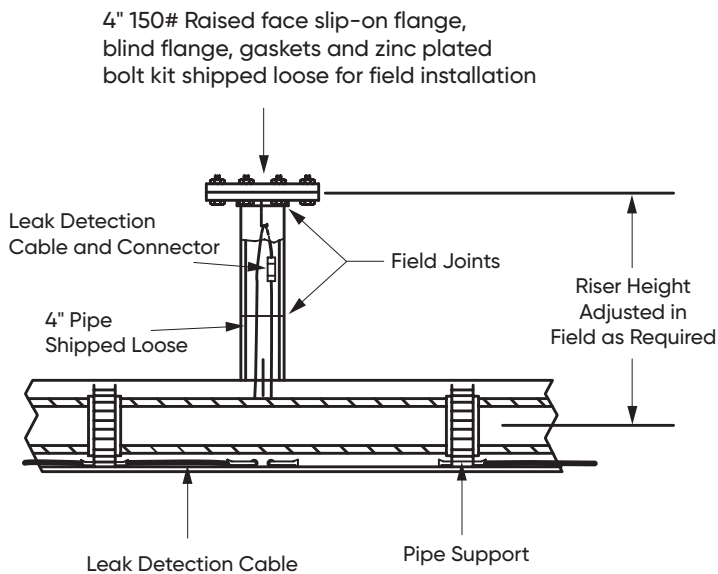

Note: Steel, Stainless Steel, PVC, CPVC & FRP Containment

Note: Pull port may terminate above grade in non-traffic area. Traffic rated box is required in traffic areas and is to be supplied and installed by installing contractor.

Portable Leak Detection Sensor

IPEX Portable Leak Detection Sensor for use with above ground IPEX Double Containment Piping Systems.

To complement our line of double containment systems, IPEX is pleased to announce our new Portable Leak Detection Sensor.

IPEX's electronic leak detection system allows system owners and maintenance personnel to immediately identify a leak in the piping system.

The IPEX Portable Leak Detection Sensor allows maintenance personnel to trace a leak from the low-point collection area to the exact location of the leak. This allows maintenance personnel to determine where repairs need to be made.

How does it work? The sensor comes nearly pre-assembled with easy to follow instructions.



Operation Instructions

1. Connect sensor wire as follows:
 - Brown wire = Positive Terminal, +
 - Black wire = Switch Terminal, ___ / ___
 - Blue wire = Negative Terminal, -
2. Use sensor along containment pipe where leak is being reported. Hold up sensor to make contact with the containment pipe along the 6-O'clock position.
 - Liquid detected
The alarm in the sensor will SOUND and red LED light will illuminate
 - No liquid detected
The sensor alarm will not sound and red LED light will be OFF
3. Follow the leak upwards along the sloped containment pipe with the sensor (making contact with the containment pipe), remaining along the 6-O'clock position. The leak's origin will be where the alarm sound terminates and the LED light no longer illuminates.

Description	Product Code
Portable Leak Detection Sensor	631253

SECTION SIX: VALVES

IPEX provides a number of specialty components and services. These include:

- Ball Valve – Manual & Actuated (Electric or Pneumatic)
- Check Valves
- Valve Boxes
- Expansion Loops
- Expansion Ells
- Access Tees
- Sub-Assemblies (IPEX provides isometric and detailed drawings of system)
- Detailed Stress Analysis by a licensed professional engineer

Standard prebuilt contained valves, as well as custom-built designs. Double containment valves can be built to accommodate job requirements and specifications. Below are some examples, contact IPEX for more detailed information.

Standard Ball Valve:

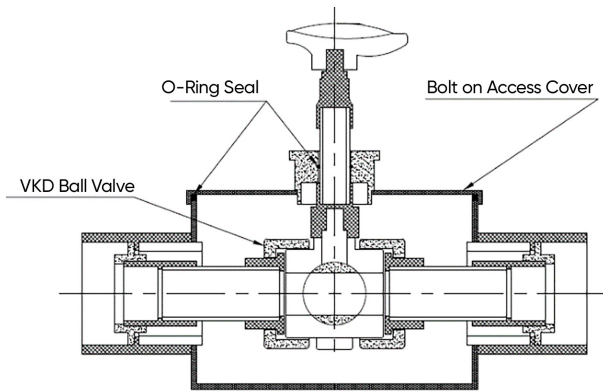

Valve with Stem Extension:

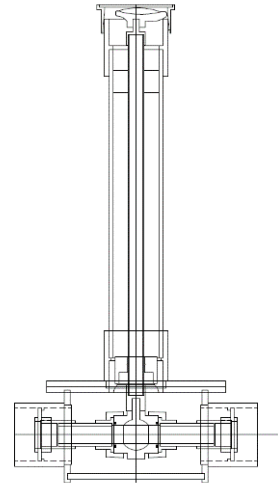

Actuated Ball Valve:

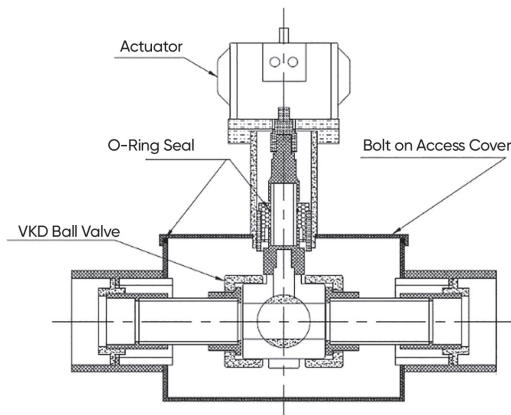

Maintainable Ball Valve:

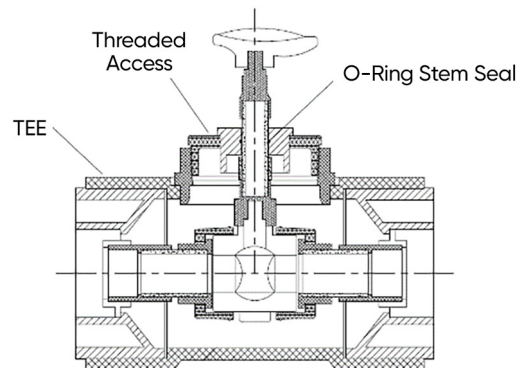

NOTES

SECTION SEVEN: SYSTEM DESIGN

External Support

Support and spacing requirements for double containment piping systems parallels overhead process piping installations. Thermoplastic materials are frequently selected as a secondary jacket. Extra support considerations should be given to components such as valves, in-line pumps, etc.

Horizontal piping systems should be supported on uniform centers, which are determined by maximum containment pipe temperatures (see support chart for recommendations). Valves apply to uninsulated lines either in a building or exposed to the environment.

Recommended Support Spacing (ft)

Below is the maximum recommend support spacing in feet:

Pipe Size (in.)	Temperature (°F)			Containment Material
	60	100	140	
1/2 x 2	4.0	3.0	2.5	Encase
1 x 3	5.0	4.0	3.5	
2 x 4	6.0	4.5	4.0	
3 x 6	7.5	5.5	5.0	
4 x 8	8.5	6.5	5.5	
6 x 10	9.5	7.5	6.5	
8 x 12	10.5	8.0	7.0	
1/2 x 2	5.2	5.0	4.6	
1 x 3	6.7	6.4	5.9	
2 x 4	7.6	7.3	6.7	
3 x 6	9.2	8.9	8.2	
4 x 8	10.7	10.2	9.5	
6 x 10	12.0	11.5	10.7	
8 x 12	13.2	12.7	11.8	
1/2 x 2	5.6	5.4	5.0	Schedule 80 PVC
1 x 3	7.2	6.9	6.4	
2 x 4	8.2	7.9	7.3	
3 x 6	10.3	9.9	9.2	
4 x 8	12.0	11.5	10.6	
6 x 10	13.7	13.1	12.1	
8 x 12	15.2	14.6	13.5	
1/2 x 2	5.3	5.1	4.8	
1 x 3	6.7	6.5	6.1	
2 x 4	7.7	7.4	7.0	
3 x 6	9.4	9.1	8.6	
4 x 8	10.8	10.5	9.9	
6 x 10	12.2	11.8	11.1	
8 x 12	13.4	13.0	12.3	
1/2 x 2	5.6	5.5	5.2	Schedule 80 CPVC
1 x 3	7.2	7.0	6.6	
2 x 4	8.3	8.1	7.6	
3 x 6	10.4	10.1	9.5	
4 x 8	12.1	11.7	11.0	
6 x 10	13.8	13.4	12.6	
8 x 12	15.4	15.0	14.1	

Regardless of the type of hanger selected, it is important to note that a wide surface is recommended, free from burrs and sharp edges. Do not anchor by means of a U-bolt directly to the containment pipe. Double containment anchors are available for all systems.

When pipe clamps are used, they should not force the pipe fittings into position. Each pipe section should be laid out and jointed to its mating section whether it is cemented or welded. Once the joints have been completed, the final clamping is done. When correctly installed, a clamp or anchor can be loosened or removed without the pipe shifting.

Stainless Steel Support Spacing

Pipe Size (in.)	Spacing (ft)
1/2 x 2	10
1 x 3	12
2 x 4	14
3 x 6	16.5
4 x 8	18.5
6 x 10	21
8 x 12	22

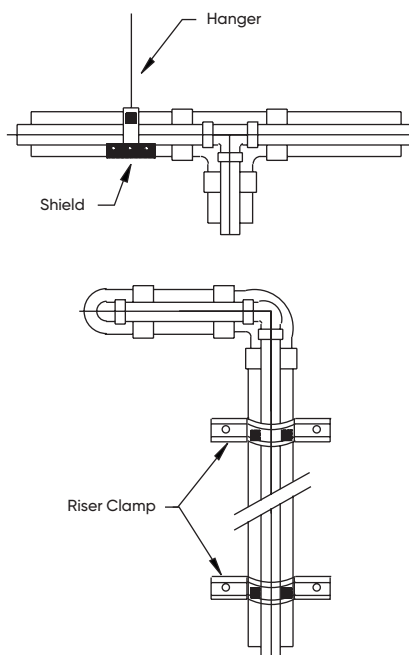

NOTES: All valves and points of concentrated loads such as tees and flanges should have supports independent of normal span supports.

Riser clamps evenly distribute vertical loads. Clamps are always placed at interstitial supports.

Regardless of the type of support, place inner and outer supports near each other. This will eliminate point loading.

Expansion Loops, Elbows, and Joints

Expansion and Contraction

One of the most frequent forms of stress that is encountered in a piping system is associated with the thermal effects that the piping is subject to. All piping products expand and contract with temperature changes. Therefore, expansion and contraction must always be taken into consideration, especially for thermoplastic piping systems. Pipe is designed to withstand internal pressures so expansion in the radial direction is minimal, the pipe will expand in the linear or longitudinal direction. There are three values required to calculate the amount of thermal expansion in a piping run. The first is the linear expansion factor. Each manufacturer will provide the linear expansion factor based on the pipe material that is selected. The second is the temperature differential. The maximum and minimum temperature of both the carrier and containment pipe. In many cases, the carrier and containment will not be exposed to the same temperatures. The carrier pipe temperature will be mostly influenced by the conveying fluid, whereas the containment pipe temperature will be mostly influenced by the surrounding environment. Along with these conditions, it is important to know the ambient conditions when the piping is being installed. In many cases, the pipes are installed at a different temperature than what will be experienced in normal operating conditions. The absolute minimum and maximum temperatures must be used. The third value is the length of the piping run before a change in direction. After gathering all this information, the linear change of the piping system can be calculated.

The length change due to thermal expansion or contraction depends on the linear expansion factor of the piping material, the system temperature differential (absolute maximum and minimum), and the length of pipe run between changes in direction. The amount of linear pipe expansion can be determined using the following formula:

$$\Delta L = \frac{Y (T - F)}{10} \times \frac{L}{100}$$

- ΔL = the change in length (in.)
- Y = the linear expansion factor (in./10°F/100ft of pipe)
- T = the maximum temperature (°F)
- F = the minimum temperature (°F)
- L = the length of pipe run (ft)

The thermal stress and thermal force generated in a piping system are required to determine if compensating for thermal effects is necessary. The axial thermal stress generated in a pipe and the thermal force are determined with these equations:

$$S = e \times \Delta T \times E$$

- S = the axial thermal stress (psi), tensile or compressive
- e = the coefficient of thermal expansion (in./in./°F)
- ΔT = the temperature difference (°F)
- E = the modulus of elasticity (psi)

$$F = S \times A$$

- F = the thermal force (lbs), tensile or compressive
- S = the axial thermal stress (psi)
- A = the cross-sectional area of the pipe wall (πr^2)

Unwanted stresses resulting from thermal expansion and contraction can be directed to areas designed to safely absorb the stresses. This can be done by incorporating offsets, expansion loops, or expansion joints.

IPEX Guardian™ systems come standard with restrained carrier fittings. Patented Centra-Lok™ fittings lock the carrier and containment fittings together while centralizers in the pipe stabilize the carrier pipe.

Systems with a low change in temperature and buried systems are typically able to be fully or partially restrained. In a fully restrained system, the carrier pipe and fittings are rigidly attached to the containment pipe and fittings and the containment pipe is restrained from movement. In a partially restrained system, the carrier pipe is supported inside the containment and the fittings are rigidly attached to the containment. The restrained fittings in turn restrain the supported pipe. In above-ground systems, where a low change in temperature is anticipated, the carrier pipe is restrained in the containment and the thermal stress is absorbed by both the carrier and containment pipe. In buried applications, the containment pipe is restrained by the surrounding. The carrier pipe and fittings are secured to the containment and therefore any thermal stress created by the carrier pipe will be absorbed. Thermoplastic systems can handle a relatively large amount of thermal stress. It is recommended that fully restrained or partially restrained systems be analyzed for expected thermal stress loads to ensure system longevity. Systems that experience large changes in temperature resulting in large amounts of thermal stress may need offsets or expansion loops and free-floating fittings.

The following equation can be used to calculate the required offset or expansion loop size for both pipes.

To begin, calculate the expansion loop size for the carrier and containment pipes, separately, based on the calculated change in length. In most cases, the overall loop sizing will be based off the carrier conditions as the containment typically experiences less thermal fluctuation.

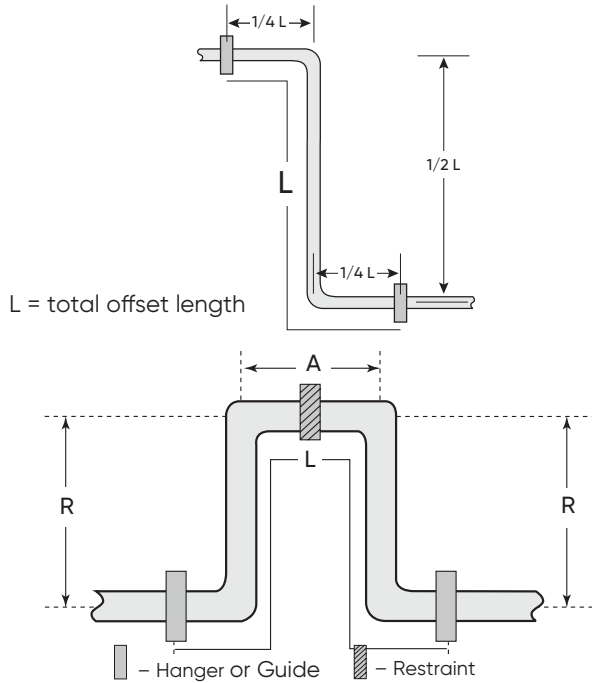

Working Stress at Elevated Temperatures (psi)

Temperature		PVC		CPVC	
°F	°C	Modulus of Elasticity	Working Stress	Modulus of Elasticity	Working Stress
73	23	400,000	2,000	423,000	2,000
90	32	372,000	1,500	403,000	1,820
110	43	336,000	1,000	371,000	1,480
140	60	280,000	440	323,000	1,000
160	71	—	—	291,000	750
180	82	—	—	269,000	500
200	93	—	—	220,000	400

$$L = \sqrt{\frac{3ED(\Delta l)}{S}}$$

where:

- L = total expansion loop length (in)
- E = modulus of elasticity at maximum operating temperature (psi)
- S = working stress at maximum operating temperature (psi)
- D = nominal outside diameter of pipe (in)
- Δl = change in length due to thermal expansion or contraction (in)
- R = expansion loop leg length (2/5 L)
- A = expansion loop leg length (1/5 L)

Offsets and expansion loops will contain free-floating pipe and fittings; therefore, it must be confirmed that there will not be interferences between carrier and containment components. The following chart shows the free (interstitial) space between double-contained pipe and fittings and can be used to confirm the sizing.

Free Space – Schedule 40 and Schedule 80 PVC Fittings

Size (in.)	Free Space Area (in.)	Size (in.)	Free Space Area (in.)
1 x 3	0.400	4 x 8	1.500
1 x 4	0.950	4 x 10	1.750
1 x 6	2.000	4 x 12	3.500
2 x 4	0.300	6 x 10	1.300
2 x 6	1.250	6 x 12	2.100
2 x 8	2.750	6 x 14	2.500
3 x 6	0.750	8 x 12	1.000
3 x 8	1.375	8 x 14	1.600
3 x 10	3.000	8 x 16	2.200

NOTE: Free space area denotes maximum movement of carrier to initial interference with containment

When free-floating fittings are required, the bottom elbows will be replaced with tee fittings. These are needed to allow the installer to properly solvent cement the carrier pipe and fitting.

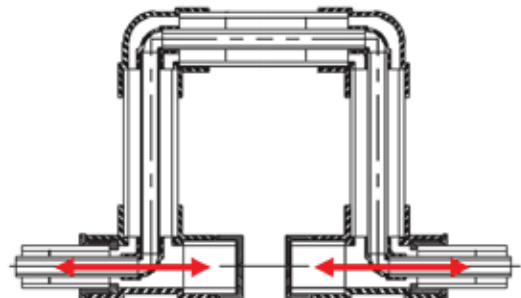
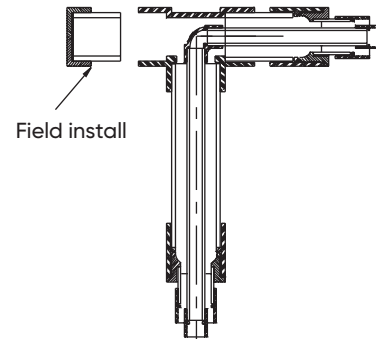

In some cases, it may be necessary to have an oversized containment pipe and fittings in the expansion loop to avoid interference. IPEX will supply expansion loop components with the required containment size. Expansion loops should not be field-assembled. These engineered systems should be purchased from the manufacturer to ensure that the system will properly accommodate the working conditions.

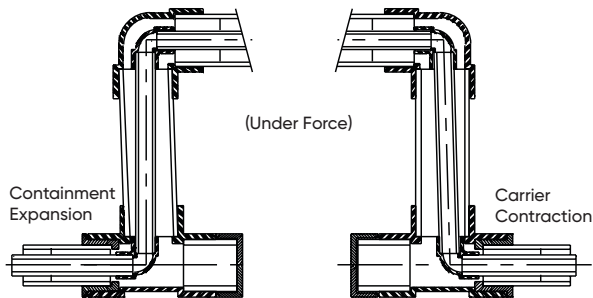
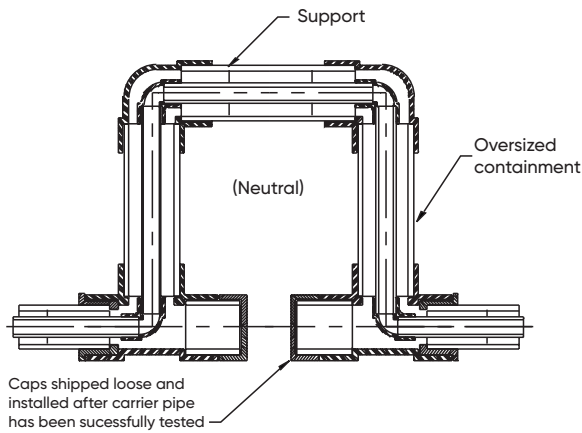

Expansion Joints

IPEX manufactures an expansion joint that provides an easy-to-install solution for the complex expansion and contraction of a double-contained piping system.

- 6" of travel for both carrier and containment pipe
- Triple O-ring design for a reliable watertight seal
- Independent movement for both carrier and containment pipe
- Tap and plug on containment for drainage
- Piston guides to ensure smooth motion without buckling
- Pressure rated design up to 235 psi

IPEX Guardian Double Containment Expansion Joints are engineered to accommodate the various expansions and contractions found in a multiple material, multiple size contained piping system. The carrier and containment pipe can expand and contract independently of each other to ensure proper compensation regardless of material selection, pipe size, or layout differences. The expansion joint is shipped fully assembled, using factory-tested joints, to eliminate the need for costly field joints that could create leak paths.

Double Containment – Expansion Joint Above Ground Installation

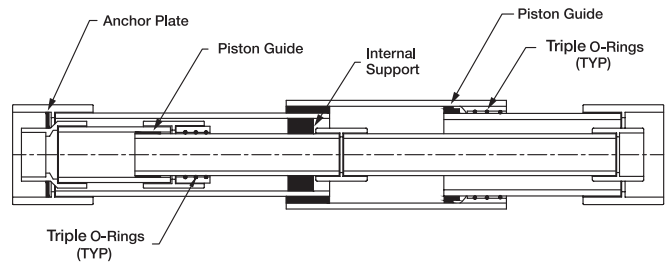

Installation of Buried Pipes

Introduction

All single wall buried piping systems are subjected to both internal and external loads. However, containment pipe does not experience internal loading. For external loads, vinyl pipe is considered flexible (able to bend without breaking) and uses the pipe wall and the surrounding soil medium to support external loads. In other words, the soil and pipe form an integral structure. Depending on the loading characteristics, the pipe will either deflect or compress.

The external loads that need to be determined are earth, static and dynamic. Detail on determining external load characteristics is beyond the scope of this manual. For further information on determining load characteristics, the user is directed to other engineering textbooks such as the Uni-Bell Handbook of PVC Pipe.

Trench Preparation

Engineering documents for a project will specify the correct line and grade for the trench, however, it is important to keep a few things in mind during the trenching operation.

Although the width at the top of the trench is generally dictated by local conditions, the width in the pipe zone should be as narrow as practical. The general rule is that the maximum width at the top of the pipe should not be more than the outside diameter of the pipe plus 24 inches. If trench width cannot be controlled and will exceed the maximum, then compacted backfill must be provided for a distance of 2 1/2 pipe diameters on either side of the pipe to the trench wall for pipe sizes up to 10 inches. For larger size pipe (14" to 24"), the compacted haunching material should be placed one pipe diameter or 24 inches (whichever is greater) to either side of the pipe.

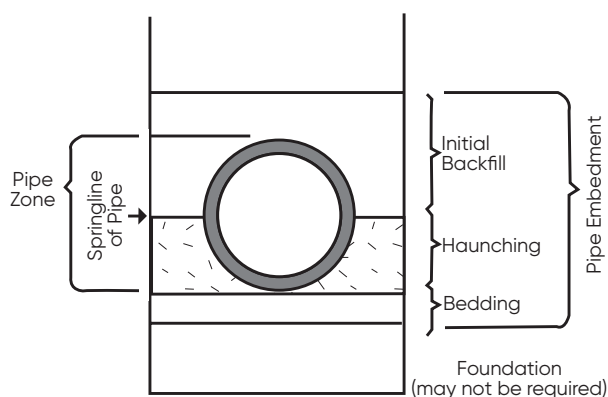

Trench Depth

As mentioned in the Design section of this manual, thermoplastic pipe will tend to deflect rather than crack under loading. The amount of deflection can be derived from the depth of burial, pipe stiffness, and the amount of loading (e.g. soil, traffic) on the pipe. Although the maximum allowable deflection is 7.5% at a 4:1 safety factor, critical buckling occurs at 30%. For a given situation, the actual deflection and burial depth can be calculated.

For more detail regarding burial depth and estimating deflection under different conditions, consult your IPEX representative.

Minimum Cover

Although the project may have specifications for the required depth of burial, the following guidelines for minimum cover may prove helpful:

- Pipe should be placed 6 inches below the frost line
- For expected truck traffic (live loading - Highway H20), use a minimum cover of 12 inches (or 1 pipe diameter, whichever is greater) providing a minimum soil stiffness of $E' = 1000$.
- For expected heavy truck or train traffic, (live loading - Railway E80) use a minimum cover of 36 inches (or 1 pipe diameter, whichever is greater) providing a minimum soil stiffness of $E' = 1000$.

Maximum Cover

Pipe that is buried too deeply is also not advisable for reasons of cost and loading. For the maximum recommended cover, refer to the table below.

Maximum Recommended Cover

Soil* Class	Standard Proctor Density Range (%)	E' Modulus of Soil Reaction (psi)	Maximum Height of Cover (ft)
I	-	3000	50
	85-95	2000	50
II	75-85	1000	50
	65-75	200	17
III	85-95	1000	50
	75-85	400	28
IV	65-75	100	12
	85-95	400	28
IV	75-85	200	17
	65-75	50	9

* as per ASTM D2321

Source: Uni-Bell Plastic Pipe Association

Trench Bottom

To properly support the pipe, the trench bottom should be continuous, relatively smooth, and free of rocks. Where hardpan or boulders are encountered, the trench bottom should be padded using a minimum of 4" of crushed rock or sand beneath the pipe. Frozen material should not be used to either support or bed the pipe.

Where the soil medium is unstable, (e.g. organic material), the trench bottom should be over excavated and brought back to grade with suitable material.

Placing the Pipe

The pipe and fittings should be placed into the trench using ropes and skids, slings on a backhoe bucket, or by hand. Do not throw or drop the pipe or fittings into the trench, as damage may result. Particular care should be taken when handling pipe in cold weather, as the material is less impact resistant at reduced temperatures. Before assembly, ensure that all materials are in good condition.

Snaking of Pipe

After the PVC and CPVC pipe has been solvent welded, it is advisable to snake the pipe beside the trench. BE ESPECIALLY CAREFUL NOT TO APPLY ANY STRESS THAT WILL DISTURB THE UNDRIED JOINT. This snaking is necessary in order to allow for any anticipated thermal contraction that will take place in the newly joined pipeline.

Snaking is particularly necessary on the lengths that have been solvent welded during the late afternoon of a hot summer's day because their drying time will extend through the cool of the night when thermal contraction of the pipe could stress the joints to the point of pull out. This snaking is also especially necessary with pipe that is laid in its trench (necessitating wider trenches than recommended) and is back-filled with cool earth before the joints are thoroughly dry.

Assembly

Assemble joints in accordance with instructions found in the applicable Installation section in this manual.

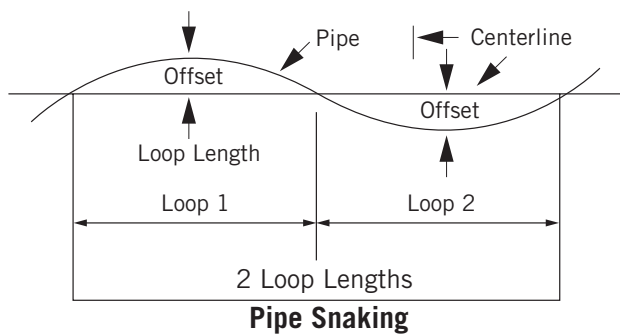

Initial Backfilling

Initial backfilling is done by covering the pipe to a depth of 6" to 12" with proper backfill material that is free from rocks, sharp objects, debris or particles larger than 3". Add layers in 6" increments ensuring that the proper compaction levels are reached for each and backfill until there is 6" to 12" of cover over the crest of the pipe.

Ensure that all joints remain exposed for visual inspection. Leave the piping to settle and normalize dimensionally then check all joints for tightness. If the piping is satisfactory then tamp the initial backfill layer.

Note 1: While tamping, ensure that the pipe alignment, both vertical and horizontal, is not disturbed.

Note 2: During hot weather it is recommended that backfilling be done in the cooler morning hours when the piping is fully contracted to avoid improper compaction due to pipe expansion.

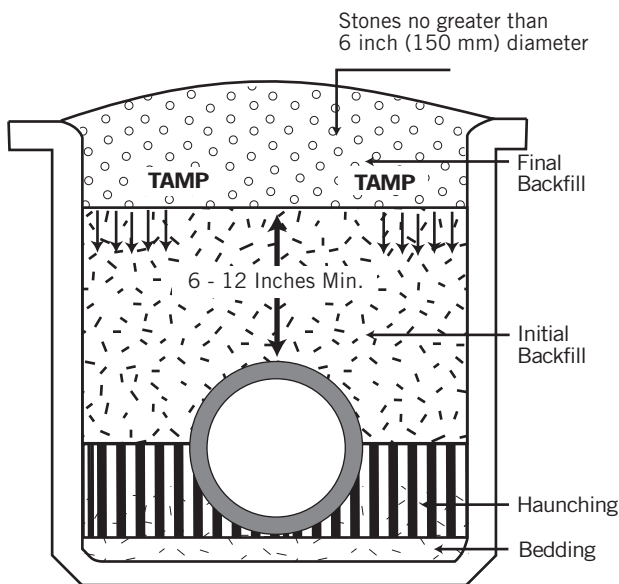

System Testing

After the system has been assembled and initially backfilled, the system must be tested for leaks. Note that the pipe must be sufficiently backfilled to prevent movement during testing.

Conduct a pressure test as per the testing procedure in this manual in the applicable Installation section under Testing. If the test is passed, the system can be covered. If not, make the necessary repairs and test again until the system is sound.

Compacting the Final Backfill

Final backfilling is the material that is placed over the initial backfill to the top of the trench.

Compact the haunching, initial backfill and final backfill using manual equipment in accordance with the job drawings. Observe the following precautions.

1. When a "self-compacting" material is used, such as crushed stone, ensure that the material does not arch or bridge beneath the haunch of the pipe. Remove such voids with the tip of a spade.
2. When compacting the material underneath and at either side of the pipe do not allow the tool or the machine to strike the pipe.
3. When compaction in excess of 85% standard proctor density is required in the haunching area ensure that the compacting effort does not dislodge the pipe from the correct grade. If the compacting effort dislodges the pipe, re-lay the pipe to the correct grade.
4. It is not necessary to compact the initial backfill directly over the top of the pipe for the sake of the pipe's structural strength. However, it may be necessary for the sake of roadway integrity.
5. When laying long runs of piping in elevated air temperatures, it is advisable to begin working from a fixed point – such as the entry or exit from a building, and work away from that point, testing and backfilling in accordance with preceding paragraphs. This procedure should then allow the piping to assume soil temperature progressively as work proceeds.

Installation Considerations

Entrapped Air

Air entrapment in pressure pipelines is a much studied and discussed topic. Most designers are concerned about it but may not understand the full implications of the problem or the processes used to reduce the dangers associated with entrapped air. The problem with entrapped air is that it is a complex issue. The behavior of air in a piping system is not easy to analyze, but the effects can be devastating.

Sources of Air in Pipelines

There are many potential sources for air in pipelines and the sources are usually multiple in any given system. The most likely source occurs during filling, either initially or when refilled after drainage. In some systems, air re-enters each time the pumps are shut off as the pipelines drain through low lying sprinklers or open valves.

Air is often introduced at the point where water enters the system. This is an especially common problem with gravity fed pipelines, but may occur with pumped systems as well. Even water pumped from deep wells may be subject to air entering from cascading water in the well.

A less obvious source of air comes from the release of dissolved air in the water, due to changes in temperature and/or pressure. The quantities may be small in this case, but accumulations over time can create problems.

It is also common for air to enter through mechanical air release valves or vacuum breakers when the pressure drops below atmospheric pressure. This can occur during pump shutdown or during negative surges.

Why is Entrapped Air a Problem?

Air in a piping system tends to accumulate at high points during low flow or static conditions. As the flowrate increases, the air can be forced along the pipeline by the moving water and may become lodged at the more extreme high points where it reduces the area available for flow. Thus, these pockets of air cause flow restrictions that reduce the efficiency and performance of the system.

As an air pocket grows, the velocity past that point increases until eventually the air is swept on toward an outlet. While line restrictions are problems, a more serious situation can occur when air is rapidly vented from the system under pressure. Water is about five times more dense than air at 100 psi, so when a pocket of compressed air reaches an outlet, such as a sprinkler head or air release valve, it escapes very rapidly. As it escapes, water rushes in to replace the void.

When water reaches the opening, the velocity suddenly decreases, since air escapes about five times faster than water at 100 psi. The result is similar to instantaneous valve closure, except that the velocity change can far exceed

the normal flow velocity in the pipeline. During tests at Colorado State University, pressure surges up to 15 times the operating pressure have been recorded when entrapped air was rapidly vented under pressure. Such pressure surges can easily exceed the strength of the system components and even at lower magnitudes, repeated surges will weaken the system over time.

Dealing with Entrapped Air - Carrier Pipe

The best way to reduce problems caused by entrapped air would be to prevent it from entering the system in the first place. Precautions should be taken to eliminate air entrance.

When systems are filled, either initially or after draining for winterization or repair, they should be filled slowly, at a velocity of 1.0 fps or less, and the air should be vented from the high points before the system is pressurized. Even with these precautions, some air can remain in the system.

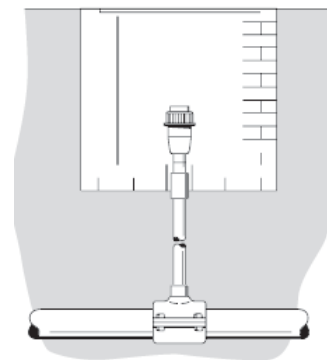

To deal with this remaining air or newly admitted air generated by the process itself, one or more continuous-acting air relief valves should be incorporated in the line. One solution would be to use manual vent valves such as ball valves. This solution is not ideal as strategically positioned manual vent valves can deal with entrapped air at startup, but will not deal automatically or effectively with recurring air entrapment problems. In addition, manually operated vents will inevitably lead to spills potentially resulting in site contamination or operator injury (depending on the carried media).

To ensure an effective means of dealing with entrapped air, continuous acting valves should be the preferred choice. Continuous-acting valves contain a float mechanism which allows the air to vent through a small orifice, even when the line is pressurized.

Also available on the market are combination air-release/vacuum breaking valves. These products have dual functions. For example, when a tank is being filled, the entrapped air is allowed to escape and the liquid is allowed to rush in unopposed by air pockets. When the process is reversed, during the draining of a tank, the valve shutting mechanism opens the valve allowing air to rush in and replace the volume previously held by the liquid, thus preventing the formation of a potentially damaging vacuum.

IPEX offers the VA Air Release valve, a piston style air-release/vacuum breaker valve in 3/4", 1-1/4" and 2" sizes. It is important to note that the open and close functions of this 'smart' valve are controlled by media and not pressure as in other air-release valves. This feature provides several advantages. No minimum pressure or vacuum is required to either open or close the valve, thus guaranteeing responsiveness in any and all conditions while eliminating the potential for spillage.



Heat Tracing

Although thermoplastic pipes are poor conductors of heat, heat tracing may be necessary to maintain a constant elevated temperature for a viscous liquid, to prevent liquid from freezing, or to prevent a liquid such as 50% sodium hydroxide, from crystallizing in a pipeline. Electric heat tracing with self-regulating temperature-sensing tape will maintain a 90°F (32°C) temperature to prevent sodium hydroxide from freezing. The tape should be S-pattern-wrapped on the pipe, allowing for pipe repairs and avoiding deflection caused by heating one side of the pipe.

Heat tracing should be applied directly on the outside of the containment pipe within the insulation, and must not exceed the temperature, pressure or chemical resistance design of the system.

In some cases, it may be necessary to install 2 or more cables with reduced output to ensure a more even heat distribution and penetration without exceeding the maximum operating temperature of the pipe.

NOTES

SECTION EIGHT: SPECIFICATIONS

Encase™

Scope of Work

Furnish all labor, materials, equipment, and incidentals required to install a Schedule 40 polypropylene double containment piping system joined by the Enfusion method.

Qualifications

The double containment piping system shall be an Encase pre-fabricated system as manufactured by IPEX. The system shall be fabricated, installed, and tested in accordance with IPEX's recommendations and as specified herein and shall be suitable for the intended service. Manufacturer shall have a minimum of five (5) years of experience. Contractor shall not design and/or fabricate the piping system.

General

All pipes and fittings shall be factory assembled with the primary and secondary pipes joined with tight-fitting pipe clips on each end allowing for lateral movement if required. The fittings shall be anchored with plates and pipe clips for supports. All piping components shall be manufactured to Schedule 40 dimensions.

All factory joints shall be made either by butt fusion or Enfusion. Joining by means of fillet welding is expressly forbidden.

All site joints shall be made using Enfusion couplings, manufactured from polypropylene with an integral nickel/chrome resistance wire. Components with copper wire elements are prohibited. Solvent, butt-welded, or fillet-welded site joints are also prohibited.

Material

Pipe, fittings, internal pipe supports, and anchor plates shall be manufactured from Type 1 homopolymer or Type 2 copolymer polypropylene material as described in ASTM D4101.

Installation

Installation shall be in accordance with the contract drawings, the manufacturer's recommendations, and the local plumbing code. The entire installation shall be installed in proper alignment and free of stress.

Testing

The system shall be tested in accordance with the manufacturer's recommendations and the local plumbing code. The primary pipe shall be tested prior to making the secondary joints.

If secondary pipe cannot be hydro-tested, as determined by the engineer or authority having jurisdiction, then the use of nitrogen or air at a MAXIMUM 5 psi (gauge) shall be allowed. It is imperative that a working pressure regulator be used during the pneumatic test to ensure that over-pressurization of the PP, beyond 5 psi, cannot occur. The following must also be noted: air or nitrogen under pressure is compressed and therefore poses a potential hazard. If a failure of the pipe or fitting occurs during such a test, the air exits at the failure point and expands rapidly. This increase in velocity can cause the system to fail in a catastrophic mode. Therefore, during such an air test, all personnel involved in the test or present in the test surrounding area must be aware of such a possibility and take all necessary precautions. Precautions include, but are not limited to, taking extreme care not to impact or damage the system in any way.

Such procedure is a limited exception to IPEX standard policy which forbids the use of its rigid systems with any compressed gases.

Guardian™

Vinyl Double Containment Pressure Piping System

Scope of Work

Furnish all labor, materials, equipment, and incidentals required to install a [PVC] or [CPVC], [Schedule 40] or [Schedule 80] (Primary) / [PVC] or [CPVC], [Schedule 40] or [Schedule 80] or Clear PVC Schedule 40 (Secondary) double containment piping, valves and appurtenances for complete systems as shown on the drawings and as specified herein.

Qualifications

The double containment piping system shall be a Guardian pre-fabricated system as manufactured by IPEX. The system shall be fabricated, installed, and tested in accordance with IPEX's recommendations and as specified herein and shall be suitable for the intended service. Manufacturer shall have a minimum of five (5) years of experience. Contractor shall not design and/or fabricate the piping system.

General

Each contained piping system shall consist of a XIRTEC [PVC] or [CPVC], [Schedule 40] or [Schedule 80] primary piping system supported within [PVC] or [CPVC], [Schedule 40] or [Schedule 80], or Clear PVC Schedule 40 secondary containment housing. Primary fitting sizes 1/2" through 4" will utilize Centra-Lok™ [U.S. Patent No. 5,398,973] molded supports minimizing the number of (factory assembled) fitting joints. Primary sizes 6" and larger will use IPEX standard fabricated Centra-Lok discs to support and centralize. Each system shall be provided with suitable drains to provide complete drainage of the secondary containment piping. Interstitial supporting devices shall be made from polypropylene Centra-Guide supports and shall be provided within the secondary containment pipe and shall be designed to allow continuous drainage in the annular space to the drain points. Drain fittings shall be designed to allow a valve attachment to be made so that the secondary containment compartment may be readily drained and manually checked for leaks.

Materials

The primary pipe and fittings shall be manufactured from [PVC] or [CPVC], [Schedule 40], or [Schedule 80] materials as manufactured by IPEX and as listed by ASTM D1784 and ANSI.

The secondary containment pipe and fittings shall be manufactured from [PVC] or [CPVC], [Schedule 40] or [Schedule 80], or Clear PVC Schedule 40 materials as manufactured by IPEX and as listed by ASTM D1784 and ANSI.

All listed primary pipe and containments shall be IPEX's [Schedule 40] or [Schedule 80] materials. All listed pressure fittings shall be manufactured according to [PVC Schedule 40 – ASTM D1785] or [PVC Schedule 80 – ASTM D1785] or [CPVC Schedule 40 – ASTM F441] or [CPVC Schedule 80 – ASTM F441] specifications. All other unlisted components that are intended for use as pressure retaining components shall have sufficient thickness and reinforcement so as to be able to maintain the same pressure ratings as the equivalent specified pipe.

Interstitial supporting devices used to center and support the primary piping within the secondary containment piping shall be manufactured from polypropylene Centra-Guide supports, designed to allow continuous drainage in the annular space.

All fittings will be pre-assembled (1/2" through 4" carrier fittings will be supported with the Centra-Lok [U.S. Patent No. 5,398,973] system, 6" and larger carrier will be supported with IPEX standard fabricated Centra-Lok discs.

Installation

All installation procedures shall be according to the manufacturer's (IPEX) specific recommendations. The manufacturer shall furnish the services of a competent representative to instruct the contractor's personnel prior to the start of installation.

All secondary containment joints shall be solvent-cemented joints using a PVC cement ASTM D2564, made in accordance with the ASTM D2855 procedure. The splitting and re-welding of fittings shall not be permitted. The use of hot gas welding for pressure-retaining joints shall be kept to those locations where it is deemed necessary by IPEX.

Installation cont.

All contractor personnel that will prepare solvent cemented joints shall be qualified for such bonding practices according to the bonding qualification procedures described in ASME B 31.3, Chapter VII for bonding of plastic piping.

Testing

Upon completion of installation, the primary piping system shall be hydrostatically pressure tested at 150% of the system design pressure (without exceeding the maximum pressure rating of the pipe) for a period of one hour.

Upon completion of the installation, the secondary containment piping system shall be pneumatically tested at a minimum duration of 2-1/2 hours. The external joints should be visually inspected for leaks. It is imperative that a working pressure regulator be used during the pneumatic test to ensure that over-pressurization of the PVC, beyond 5 psi cannot occur. Also, all precautions should be taken to protect against the hazards of a possible brittle fracture of PVC under compressed gas.

Sample Specification

All listed primary pipe shall be XIRTEC [PVC] or [CPVC], [Schedule 40], or [Schedule 80] according to ASTM. All other unlisted components that are intended for use as pressure retaining components shall have sufficient thickness and reinforcement so as to be able to maintain the same pressure ratings as the equivalent [Schedule 40] or [Schedule 80], [PVC], or [CPVC] pipe.

Interstitial supporting devices used to center and support the primary piping within the secondary containment piping shall be manufactured from polypropylene Centra-Guide supports, designed to allow continuous drainage in the annular space.

All listed secondary containment pipe and fittings shall be XIRTEC [PVC] or [CPVC], [Schedule 40] or [Schedule 80], or Clear PVC Schedule 40. Containment fittings shall have carrier components pre-assembled, supported, and tested. Containment fittings shall have spigot ends to allow for a closure coupling to be installed after primary system is pressure tested. All other unlisted components that are intended for use as pressure retaining components shall have sufficient thickness and reinforcement so as to be able to maintain the same pressure ratings as the equivalent [Schedule 40] or [Schedule 80], [PVC], or [CPVC] pipe and fittings.

All fittings will be pre-assembled and pre-tested by the manufacturer (IPEX).

CustomGuard®

Stainless Steel / Vinyl Double Containment Piping System

Scope of Work

Furnish all labor, materials, equipment, and incidentals required to install a CustomGuard [Schedule 10] or [Schedule 40], [T316L] or [T304L] Stainless Steel (Primary) / Schedule 40 [PVC] or [CPVC] (Secondary) double containment piping, valves and appurtenances for complete systems as shown on the drawings and as specified herein.

Qualifications

The double containment piping system shall be a CustomGuard pre-fabricated system as manufactured by IPEX. The system shall be fabricated, installed, and tested in accordance with IPEX's recommendations and as specified herein and shall be suitable for the intended service. Manufacturer shall have a minimum of five (5) years of experience. Contractor shall not design and/or fabricate the piping system.

General

Each contained piping system shall consist of [Schedule 10] or [Schedule 40] [T304L] or [T316L] Stainless Steel primary piping system supported within a Schedule 40 [PVC] or [CPVC] secondary containment housing. Interstitial supporting devices shall be made from polypropylene Centra-Guide supports and shall be provided within the secondary containment pipe and shall be designed to allow continuous drainage in the annular space to the drain points. Drain fittings shall be designed to allow a valve attachment to be made so that the secondary containment compartment may be readily drained and manually checked for leaks.

Materials

The primary pipe and fittings shall be manufactured from [Schedule 10] or [Schedule 40] [T304L] or [T316L] Stainless Steel materials as listed by ASTM and ANSI.

The secondary containment pipe and fittings shall be manufactured from Schedule 40 [PVC] or [CPVC] as listed by ASTM.

Installation

All installation procedures shall be according to the manufacturer's (IPEX) specific recommendations. The manufacturer shall furnish the services of a competent representative to instruct the contractor's personnel on proper installation methods prior to the start of the project.

All primary piping welds shall be made using gas arc welding (GAW, TIG, or MIG) techniques according to ASME B31.3. All welding shall be performed by a certified pipe welder.

All secondary containment joints shall be solvent-cemented joints using a [PVC] or [CPVC] cement, made in accordance with the ASTM D2855 procedure. The splitting and re-welding of fittings shall not be permitted. The use of hot gas welding for pressure-retaining joints shall be kept to those locations where it is deemed necessary by IPEX.

All contractor personnel that will prepare gas welded stainless steel field welds shall be qualified to do so according to the requirements of the ASME Boiler and Pressure Vessel Code, by sufficient experience, or by some other agreed method.

Testing

Upon completion of installation, the primary piping system shall be hydrostatically or pneumatically pressure tested at 150% of the system design pressure (without exceeding the maximum pressure rating of the pipe) for a period of one hour.

After successful testing of the primary piping system, the secondary containment piping system shall be pneumatically tested at a minimum duration of 2-1/2 hours. The external joints should be visually inspected for leaks. It is imperative that a working pressure regulator be used during the pneumatic test to ensure that over-pressurization of the PVC, beyond 5 psi cannot occur. Also, all precautions should be taken to protect against the hazards of a possible brittle fracture of PVC under compressed gas.

Sample Specification

All listed primary pipe shall be [Schedule 10] or [Schedule 40] thickness according to ANSI. All other unlisted components that are intended for use as pressure retaining components shall have sufficient thickness and reinforcement so as to be able to maintain the same pressure ratings as the equivalent [Schedule 10] or [Schedule 40] stainless steel pipe.

Interstitial supporting devices used to center and support the primary piping within the secondary containment piping shall be manufactured from polypropylene Centra-Guide supports, designed to allow continuous drainage in the annular space.

All listed secondary containment pipe and fittings shall be Schedule 40 thickness. Containment fittings shall have carrier components pre-assembled, supported, and tested. Containment fittings shall have spigot ends to allow for a closure coupling to be installed after primary system is pressure tested. All other unlisted components that are intended for use as pressure retaining components shall have sufficient thickness and reinforcement so as to be able to maintain the same pressure ratings as the equivalent Schedule 40 [PVC] or [CPVC] pipe and fittings.

All fittings will be pre-assembled and pre-tested by the manufacturer (IPEX).

CustomGuard®

Stainless Steel / Stainless Steel Double Containment Piping System

Scope of Work

Furnish all labor, materials, equipment, and incidentals required to install a CustomGuard [Schedule 10] or [Schedule 40], [T316L] or [T304L] Stainless Steel (Primary) / [Schedule 10] or [Schedule 40], [T316L] or [T304L] Stainless Steel (Secondary) double containment piping, valves and appurtenances for complete systems as shown on the drawings and as specified herein.

Qualifications

The double containment piping system shall be a CustomGuard pre-fabricated system as manufactured by IPEX. The system shall be fabricated, installed, and tested in accordance with IPEX's recommendations and as specified herein and shall be suitable for the intended service. Manufacturer shall have a minimum of five (5) years of experience. Contractor shall not design and/or fabricate the piping system.

General

Each contained piping system shall consist of [Schedule 10] or [Schedule 40] [T304L] or [T316L] Stainless Steel primary piping system supported within a [Schedule 10] or [Schedule 40] [T304L] or [T316L] Stainless Steel secondary containment housing. Interstitial supporting devices shall be made from polypropylene Centra-Guide supports and shall be provided within the secondary containment pipe, and shall be designed to allow continuous drainage in the annular space to the drain points. Drain fittings shall be designed to allow a valve attachment to be made so that the secondary containment compartment may be readily drained and manually checked for leaks.

Materials

The primary pipe and fittings shall be manufactured from [Schedule 10] or [Schedule 40] [T304L] or [T316L] Stainless Steel materials as listed by ASTM and ANSI.

The secondary containment pipe and fittings shall be manufactured from [Schedule 10] or [Schedule 40] [T304L] or [T316L] Stainless Steel.

Coating (optional)

Secondary containment pipe shall have a bonded PE coating approximately 50 mil thick on exterior.

Installation

All installation procedures shall be according to the manufacturer's (IPEX) specific recommendations. The manufacturer shall furnish the services of a competent representative to instruct the contractor's personnel on proper installation methods prior to the start of the project.

All primary piping welds shall be made using gas arc welding (GAW, TIG, or MIG) techniques according to ASME B31.3. All welding shall be performed by a certified pipe welder.

Secondary containment joints shall be slip style closure couplings using (GAW, TIG, or MIG) ASME B31.3. The splitting and re-welding of fittings shall not be permitted.

All contractor personnel that will prepare gas welded stainless steel field welds shall be qualified to do so according to the requirements of the ASME Boiler and Pressure Vessel Code, by sufficient experience, or by some other agreed method.

Testing

Upon completion of installation, the primary piping system shall be hydrostatically or pneumatically pressure tested at 150% of the system design pressure (without exceeding the maximum pressure rating of the pipe) for a period of one hour.

After a successful test has been performed on the primary pipe and all secondary closure couplings and end terminations have been installed, the secondary containment piping system shall be pneumatically tested at a pressure equal to the primary pipe test for a minimum of one hour.

Sample Specification

All listed primary pipe shall be [Schedule 10] or [Schedule 40] thickness according to ANSI. All listed pressure fittings shall be [Schedule 10] or [Schedule 40] according to ANSI. All other unlisted components that are intended for use as pressure retaining components shall have sufficient thickness and reinforcement so as to be able to maintain the same pressure ratings as the equivalent [Schedule 10] or [Schedule 40] stainless steel pipe.

Interstitial supporting devices used to center and support the primary piping within the secondary containment piping shall be manufactured from polypropylene Centra-Guide supports, according to ASTM and ANSI.

All listed secondary containment pipe and fittings shall be [Schedule 10] or [Schedule 40] thickness. Containment fittings shall have carrier components pre-assembled, supported, and tested. Containment fittings shall have spigot ends to allow for a closure coupling to be installed after primary system is pressure tested. All other unlisted components that are intended for use as pressure retaining components shall have sufficient thickness and reinforcement so as to be able to maintain the same pressure ratings as the equivalent [Schedule 10] or [Schedule 40] stainless steel pipe and fittings.

All fittings will be pre-assembled and pre-tested by the manufacturer (IPEX).

CustomGuard®

Stainless Steel / Carbon Steel Double Containment Piping System

Scope of Work

Furnish all labor, materials, equipment, and incidentals required to install a CustomGuard [Schedule 10] or [Schedule 40], [T316L] or [T304L] Stainless Steel (Primary) / Schedule 10 Carbon Steel (Secondary) double containment piping, valves and appurtenances for complete systems as shown on the drawings and as specified herein.

Qualifications

The double containment piping system shall be a CustomGuard pre-fabricated system as manufactured by IPEX. The system shall be fabricated, installed, and tested in accordance with IPEX's recommendations and as specified herein and shall be suitable for the intended service. Manufacturer shall have a minimum of five (5) years of experience. Contractor shall not design and/or fabricate the piping system.

General

Each contained piping system shall consist of [Schedule 10] or [Schedule 40] [T304L] or [T316L] Stainless Steel primary piping system supported within a Schedule 10 Carbon Steel secondary containment housing. Interstitial supporting devices shall be made from polypropylene Centra-Guide supports and shall be provided within the secondary containment pipe and shall be designed to allow continuous drainage in the annular space to the drain points. Drain fittings shall be designed to allow a valve attachment to be made so that the secondary containment compartment may be readily drained and manually checked for leaks.

Materials

The primary pipe and fittings shall be manufactured from [Schedule 10] or [Schedule 40] [T304L] or [T316L] Stainless Steel materials as listed by ASTM and ANSI.

The secondary containment pipe and fittings shall be manufactured from Schedule 10 Carbon Steel.

Coating

Secondary containment pipe shall have a 12-14 mil FBE (fusion bonded epoxy) per AWWA C213.

Installation

All installation procedures shall be according to the manufacturer's (IPEX) specific recommendations. The manufacturer shall furnish the services of a competent representative to instruct the contractor's personnel on proper installation methods prior to the start of the project.

All primary piping welds shall be made using gas arc welding (GAW, TIG, or MIG) techniques according to ASME B31.3. All welding shall be performed by a certified pipe welder.

Secondary containment joints shall be slip style closure couplings using (GAW, TIG, or MIG) ASME B31.3. The splitting and re-welding of fittings shall not be permitted.

All contractor personnel that will prepare gas welded steel field welds shall be qualified to do so according to the requirements of the ASME Boiler and Pressure Vessel Code, by sufficient experience, or by some other agreed method.

Testing

Upon completion of installation, the primary piping system shall be hydrostatically or pneumatically pressure tested at 150% of the system design pressure (without exceeding the maximum pressure rating of the pipe) for a period of one hour.

After a successful test has been performed on the primary pipe and all secondary closure couplings and end terminations have been installed, the secondary containment piping system shall be pneumatically tested at a pressure equal to the primary pipe test for a minimum of one hour.

Sample Specification

All listed primary pipe shall be [Schedule 10] or [Schedule 40] thickness according to ANSI. All listed pressure fittings shall be [Schedule 10] or [Schedule 40] according to ANSI. All other unlisted components that are intended for use as pressure retaining components shall have sufficient thickness and reinforcement so as to be able to maintain the same pressure ratings as the equivalent [Schedule 10] or [Schedule 40] stainless steel pipe.

Interstitial supporting devices used to center and support the primary piping within the secondary containment piping shall be manufactured from polypropylene Centra-Guide supports, according to ASTM and ANSI.

All listed secondary containment pipe and fittings shall be Schedule 10 thickness. Containment fittings shall have carrier components pre-assembled, supported, and tested. Containment fittings shall have spigot ends to allow for a closure coupling to be installed after primary system is pressure tested. All other unlisted components that are intended for use as pressure retaining components shall have sufficient thickness and reinforcement so as to be able to maintain the same pressure ratings as the equivalent Schedule 10 carbon steel pipe and fittings.

All fittings will be pre-assembled and pre-tested by the manufacturer (IPEX).

CustomGuard®

Carbon Steel / Carbon Steel Double Containment Piping System

Scope of Work

Furnish all labor, materials, equipment, and incidentals required to install a CustomGuard [Schedule 40] or [Schedule 80], [A53B ERW] or [A106B seamless] Carbon Steel (Primary) / [Schedule 10] or [Schedule 40], [A53B ERW] or [A106B seamless] Carbon Steel (Secondary) double containment piping, valves and appurtenances for complete systems as shown on the drawings and as specified herein.

Qualifications

The double containment piping system shall be a CustomGuard pre-fabricated system as manufactured by IPEX. The system shall be fabricated, installed, and tested in accordance with IPEX's recommendations and as specified herein and shall be suitable for the intended service. Manufacturer shall have a minimum of five (5) years of experience. Contractor shall not design and/or fabricate the piping system.

General

Each contained piping system shall consist of [Schedule 40] or [Schedule 80], [A53B ERW] or [A106B seamless] Carbon Steel primary piping system supported within a [Schedule 10] or [Schedule 40], [A53B ERW] or [A106B seamless] Carbon Steel secondary containment housing. Interstitial supporting devices shall be made from polypropylene Centra-Guide supports and shall be provided within the secondary containment pipe and shall be designed to allow continuous drainage in the annular space to the drain points. Drain fittings shall be designed to allow a valve attachment to be made so that the secondary containment compartment may be readily drained and manually checked for leaks.

Materials

The primary pipe and fittings shall be manufactured from [Schedule 40] or [Schedule 80], [A53B ERW], or [A106B seamless] Carbon Steel materials as listed by ASTM and ANSI.

The secondary containment pipe and fittings shall be manufactured from [Schedule 10] or [Schedule 40], [A53B ERW], or [A106B seamless] Carbon Steel.

Coating

Secondary containment pipe shall have a 12-14 mil FBE (fusion bonded epoxy) per AWWA C213.

Installation

All installation procedures shall be according to the manufacturer's (IPEX) specific recommendations. The manufacturer shall furnish the services of a competent representative to instruct the contractor's personnel on proper installation methods prior to the start of the project.

All primary piping welds shall be made using gas arc welding (GAW, TIG, or MIG) techniques according to ASME B31.3. All welding shall be performed by a certified pipe welder.

Secondary containment joints shall be slip style closure couplings using (GAW, TIG, or MIG) ASME B31.3. The splitting and re-welding of fittings shall not be permitted.

All contractor personnel that will prepare gas welded carbon steel field welds shall be qualified to do so according to the requirements of the ASME Boiler and Pressure Vessel Code, by sufficient experience, or by some other agreed method.

Testing

Upon completion of installation, the primary piping system shall be hydrostatically or pneumatically pressure tested at 150% of the system design pressure (without exceeding the maximum pressure rating of the pipe) for a period of one hour.

After a successful test has been performed on the primary pipe and all secondary closure couplings and end terminations have been installed, the secondary containment piping system shall be pneumatically tested at a pressure equal to the primary pipe test for a minimum of one hour.

Sample Specification

All listed primary pipe shall be [Schedule 40] or [Schedule 80] thickness according to ANSI. All listed pressure fittings shall be [Schedule 40] or [Schedule 80] according to ANSI. All other unlisted components that are intended for use as pressure retaining components shall have sufficient thickness and reinforcement so as to be able to maintain the same pressure ratings as the equivalent [Schedule 40] or [Schedule 80] carbon steel pipe.

Interstitial supporting devices used to center and support the primary piping within the secondary containment piping shall be manufactured from polypropylene Centra-Guide supports, according to ASTM and ANSI.

All listed secondary containment pipe and fittings shall be [Schedule 10] or [Schedule 40] thickness. Containment fittings shall have carrier components pre-assembled, supported, and tested. Containment fittings shall have spigot ends to allow for a closure coupling to be installed after primary system is pressure tested. All other unlisted components that are intended for use as pressure retaining components shall have sufficient thickness and reinforcement so as to be able to maintain the same pressure ratings as the equivalent [Schedule 10] or [Schedule 40] carbon steel pipe and fittings.

All fittings will be pre-assembled and pre-tested by the manufacturer (IPEX).

CustomGuard®

Copper / PVC Double Containment Piping System

Scope of Work

Furnish all labor, materials, equipment, and incidentals required to install a CustomGuard [Type K] or [Type L] or [Type M] Copper (Primary) / [Schedule 40] or [Schedule 80] PVC (Secondary) double containment piping, valves and appurtenances for complete systems as shown on the drawings and as specified herein.

Qualifications

The double containment piping system shall be a CustomGuard pre-fabricated system as manufactured by IPEX. The system shall be fabricated, installed, and tested in accordance with IPEX's recommendations and as specified herein and shall be suitable for the intended service. Manufacturer shall have a minimum of five (5) years of experience. Contractor shall not design and/or fabricate the piping system.

General

Each contained piping system shall consist of [Type K] or [Type L] or [Type M] Copper primary piping system supported within a [Schedule 40] or [Schedule 80] PVC secondary containment housing. Interstitial supporting devices shall be made from polypropylene Centra-Guide supports and shall be provided within the secondary containment pipe and shall be designed to allow continuous drainage in the annular space to the drain points. Drain fittings shall be designed to allow a valve attachment to be made so that the secondary containment compartment may be readily drained and manually checked for leaks.

Materials

The primary pipe and fittings shall be manufactured from [Type K] or [Type L] or [Type M] Copper materials as listed by ASTM and ANSI.

The secondary containment pipe and fittings shall be manufactured from [Schedule 40] or [Schedule 80] PVC as listed by ASTM D1785.

Installation

All installation procedures shall be according to the manufacturer's (IPEX) specific recommendations. The manufacturer shall furnish the services of a competent representative to instruct the contractor's personnel on proper installation methods prior to the start of the project.

All primary piping welds shall be made using gas arc welding (GAW, TIG, or MIG) techniques according to ASME B31.3. All welding shall be performed by a certified pipe welder.

All secondary containment joints shall be solvent-cemented joints using a PVC cement, made in accordance with the ASTM D2855 procedure. The splitting and re-welding of fittings shall not be permitted. The use of hot gas welding for pressure-retaining joints shall be kept to those locations where it is deemed necessary by IPEX.

All contractor personnel that will prepare gas welded copper field welds shall be qualified to do so according to the requirements of the ASME Boiler and Pressure Vessel Code, by sufficient experience, or by some other agreed method.

Testing

Upon completion of installation, the primary piping system shall be hydrostatically or pneumatically pressure tested at 150% of the system design pressure (without exceeding the maximum pressure rating of the pipe) for a period of one hour.

After successful testing of the primary piping system, the secondary containment piping system shall be pneumatically tested at a minimum duration of 2-1/2 hours. The external joints should be visually inspected for leaks.

It is imperative that a working pressure regulator be used during the pneumatic test to ensure that over-pressurization of the PVC, beyond 5 psi cannot occur. Also, all precautions should be taken to protect against the hazards of a possible brittle fracture of PVC under compressed gas.

Sample Specification

All listed primary pipe shall be [Type K] or [Type L] or [Type M] Copper thickness according to ANSI. All listed pressure fittings shall be [Type K] or [Type L] or [Type M] Copper according to ANSI. All other unlisted components that are intended for use as pressure retaining components shall have sufficient thickness and reinforcement so as to be able to maintain the same pressure ratings as the equivalent copper pipe.

Interstitial supporting devices used to center and support the primary piping within the secondary containment piping shall be manufactured from polypropylene Centra-Guide supports, according to ASTM and ANSI.

All listed secondary containment pipe and fittings shall be [Schedule 40] or [Schedule 80] thickness as listed by ASTM D1785. Containment fittings shall have carrier components pre-assembled, supported, and tested. Containment fittings shall have spigot ends to allow for a closure coupling to be installed after primary system is pressure tested. All other unlisted components that are intended for use as pressure retaining components shall have sufficient thickness and reinforcement so as to be able to maintain the same pressure ratings as the equivalent [Schedule 40] or [Schedule 80] PVC pipe and fittings.

All fittings will be pre-assembled and pre-tested by the manufacturer (IPEX).

Guardian PAL-AT Continuous Cable Leak Detection

The Leak Detection/Location System shall consist of a microprocessor-based panel capable of continuous monitoring of a sensor string for leaks, breaks, and shorts. The unit shall have a sensing range of [2,000] [5,000] [7,500] feet per cable [with up to eight cables per panel]. The alarm unit(s) shall operate on the principle of pulsed energy reflection and be capable of mapping the entire length of the sensor cable and storing the digitized system map in nonvolatile memory. The alarm unit(s) shall provide continuous indication that the sensor cable is being monitored.

The system manufacturer shall have experience with leak detection/location sensor cable technology and provide a factory-trained representative at two on-site meetings for pre-construction and sensor/electronics installation.

The alarm unit(s) shall be enclosed in a modified NEMA 12 enclosure and have a two-line by forty-character display providing status and alarm data. The monitoring unit(s) [shall be field connected to an] [shall have a factory mounted] alarm horn. The unit(s) shall have a red LED optical alarm that is illuminated when any cable is in alarm. The monitoring unit shall be UL Listed and FM Approved to provide connections for intrinsically safe sensor circuits for use in Class 1, Division 1, Group C, and D Hazardous Locations.

The system shall be tested and found to comply with the limits for a Class A digital device, pursuant to part 15 of the FCC rules and so labeled.

The system shall be evaluated by an independent third party according to the Third Party Procedures developed according to the U.S. EPA's "Standard Test Procedure for Evaluating Leak Detection Methods: Liquid-Phase Out-of-Tank Product Detectors". The evaluation results shall verify the system manufacturer's claims regarding sensitivity, range, and other performance data.

The sensor cable, connectors, [probes], and jumpers shall be supplied by the manufacturer of the monitoring unit(s).

Software will be available that allows the manufacturer to remotely or on-site interface through the RS-232 serial port for troubleshooting and diagnostics. Software shall have the ability to operate the PAL-AT monitoring units and retrieve each of the stored reference maps and current condition TDR trace.

Appendix A

Conversion Charts

Contents of Pipe

Capacities in Cubic Feet and United States Gallons (231 Cubic Inches) per foot of Length											
Dia. in.	Dia. ft.	For 1 Foot Length		Dia. in.	Dia. ft.	For 1 Foot Length		Dia. in.	Dia. ft.	For 1 Foot Length	
		ft. ³	U.S. Gal.			ft. ³	U.S. Gal.			ft. ³	U.S. Gal.
		Also Area in. ft. ²	(231 in. ³)			Also Area in. ft. ²	(231 in. ³)			Also Area in. ft. ²	(231 in. ³)
1/4	0.0208	0.0003	0.0026	4-1/4	0.3542	0.0985	0.7370	10-1/2	0.8750	0.6013	4.4980
5/16	0.0260	0.0005	0.0040	4-1/2	0.3750	0.1105	0.8263	10-3/4	0.8958	0.6303	4.7140
3/8	0.0313	0.0008	0.0057	4-3/4	0.3958	0.1231	0.9205	11	0.9167	0.6600	4.9370
7/16	0.0365	0.0010	0.0078	5	0.4167	0.1364	1.0200	11-1/4	0.9375	0.6903	5.1630
1/2	0.0417	0.0014	0.0102	5-1/4	0.4375	0.1503	1.1240	11-1/2	0.9583	0.7213	5.3950
9/16	0.0469	0.0017	0.0129	5-1/2	0.4583	0.1650	1.2340	11-3/4	0.9792	0.7530	5.6330
5/8	0.0521	0.0021	0.0159	5-3/4	0.4792	0.1803	1.3490	12	1.0000	0.7854	5.8760
11/16	0.0573	0.0026	0.0193	6	0.500	0.1963	1.4690	12-1/2	1.0420	0.8523	6.3750
3/4	0.0625	0.0031	0.0230	6-1/4	0.5208	0.2130	1.5940	13	1.0830	0.9218	6.8950
13/16	0.0677	0.0036	0.0270	6-1/2	0.5417	0.2305	1.7240	13-1/2	1.1250	0.9940	7.4350
7/8	0.0729	0.0042	0.0312	6-3/4	0.5625	0.2485	1.8590	14	1.1670	1.0690	7.9970
15/16	0.0781	0.0048	0.0359	7	0.5833	0.2673	1.9990	14-1/2	1.2080	1.1470	8.5780
1	0.0833	0.0055	0.0408	7-1/4	0.6042	0.2868	2.1440	15	1.2500	1.2270	9.1800
1-1/4	0.1042	0.0085	0.0638	7-1/2	0.6250	0.3068	2.2950	15-1/2	1.2920	1.3100	9.8010
1-1/2	0.1250	0.0123	0.0918	7-3/4	0.6458	0.3275	2.4500	16	1.3330	1.3960	10.4400
1-3/4	0.1458	0.0168	0.1250	8	0.6667	0.3490	2.6110	16-1/2	1.3750	1.4850	11.1100
2	0.1667	0.0218	0.1632	8-1/4	0.6875	0.3713	2.7770				
2-1/4	0.1875	0.0276	0.2066	8-1/2	0.7083	0.3940	2.9480				
2-1/2	0.2083	0.0341	0.2550	8-3/4		0.4175	3.1250				
2-3/4	0.2292	0.0413	0.3085	9	0.7500	0.4418	3.3050				
3	0.2500	0.0491	0.3673	9-1/4	0.7708	0.4668	3.4920				
3-1/4	0.2708	0.0576	0.4310	9-1/2	0.7917	0.4923	3.6820				
3-1/2	0.2917	0.0668	0.4998	9-3/4	0.8125	0.5185	3.8790				
3-3/4	0.3125	0.0767	0.5738	10	0.8333	0.5455	4.0810				
4	0.3333	0.0873	0.6528	10-1/4	0.8542	0.5730	4.2860				

Volume

Volume of a pipe is computed by: $V = \frac{1}{4}ID^2 \times \pi \times L \times 12$

Where: V = volume (in cubic inches)
 ID = inside diameter (in inches)
 $\pi = 3.14159$
 L = length of pipe (in feet)

Weight

1 U.S. gallon @ 50°F..... 8.33 lbs. x sg
 1 cubic foot..... 62.35 lbs. x sg
 7.48 U.S. gal.
 1 cu. ft. of water @ 50°F... 62.41 lbs.
 1 cu. ft. of water @ 39.2°F 62.43 lbs.
 (39.2°F is water temp. at its greatest density)
 1 kilogram..... 2.2 lbs.
 1 imperial gallon of water 10.0 lbs.
 1 pound..... 12 U.S. gal ÷ sg
016 cu. ft. ÷ sg

Capacity or Flow

1 U.S. gallon per minute (gpm) 0.134 cfm
500 lb. per hr. x sp. gr.
500 lb. per hr. 1 gpm ÷ sp. gr.
 1 cu. ft. per minute (cfm)449 gph
 1 cu. ft. per second (cfs)449 gpm
 1 acre foot per day227 gpm
 1 acre inch per hour454 gpm
 1 cubic meter per minute264.2 gpm
 1,000,000 gal. per day595 gpm
 Brake H.P. = $\frac{\text{gpm} \times (\text{total head in ft.}) \times (\text{specific gravity})}{(3960) \times (\text{pump eff.})}$

Appendix A Conversion Charts

Pressure Conversion BY FACTOR TO OBTAIN

Given	lb./in. ²	in. H ₂ O (at +39.2°F)	cm H ₂ O (at +4°C)	5.1715x10 ¹	2.0360	6.8948x10 ⁴	6.8948x10 ¹	7.0306x10 ⁻²	6.8947x10 ⁻²	6.8045x10 ⁻²	1.4400x10 ²	2.3067
lb./in.2	1.000	2.7680x10 ¹	7.0308x10 ¹	5.1715x10 ¹	2.0360	6.8948x10 ⁴	6.8948x10 ¹	7.0306x10 ⁻²	6.8947x10 ⁻²	6.8045x10 ⁻²	1.4400x10 ²	2.3067
in.H ₂ O (at +39.2°F)	3.6127x10 ⁻²	1.0000	2.5400	7.3554x10 ⁻²	1.8683	2.49808x10 ³	2.49808x10 ⁰	2.5399x10 ⁻³	2.4908x10 ⁻³	2.4582x10 ⁻³	5.2022	8.3333x10 ⁻²
cm H ₂ O (at +4°C)	1.4223x10 ⁻²	0.3937	1.0000	2.8958x10 ⁻²	0.7355	9.8064x10 ²	9.8064x10 ⁰	9.9997x10 ⁻⁴	9.8064x10 ⁻⁴	9.6781x10 ⁻⁴	2.0481	3.2808x10 ⁻²
in. Hg (at +32°F)	4.9116x10 ⁻¹	1.3596x10 ¹	3.4532x10 ¹	1.0000	2.5400x10 ¹	3.3864x10 ²	3.3864x10 ⁰	3.4532x10 ⁻²	3.3864x10 ⁻²	3.3421x10 ⁻²	7.0727x10 ¹	1.1330
mm Hg (Torr) (at 0°C)	1.9337x10 ⁻²	5.3525x10 ⁻¹	1.3595	3.9370x10 ⁻²	1.0000	1.3332x10 ³	1.3332x10 ⁰	1.3595x10 ⁻³	1.3332x10 ⁻³	1.3158x10 ⁻³	2.7845	4.4605x10 ⁻²
dynes/cm ² (1m bar)	1.4504x10 ⁵	4.0147x10 ⁻⁴	1.0197x10 ⁻³	2.9530x10 ⁻⁵	7.5006x10 ⁻⁴	1.0000	1.0000x10 ¹	1.0197x10 ⁻⁶	1.0000x10 ⁻⁶	9.8692x10 ⁻⁷	2.0886x10 ³	3.3456x10 ⁻⁵
newton/m ² (PASCAL)	1.4504x10 ⁻⁴	4.0147x10 ⁻³	1.0197x10 ⁻²	2.9530x10 ⁻⁴	7.5006x10 ⁻³	1.0000x10 ¹	1.0000x10 ⁰	1.0197x10 ⁻⁵	1.0000x10 ⁻⁵	9.8692x10 ⁻⁶	2.0885x10 ⁻²	3.3456x10 ⁻⁴
kgm/cm ²	1.4224x10 ¹	3.9371x10 ²	1.00003x10 ³	2.8959x10 ¹	7.3556x10 ²	9.8060x10 ⁵	9.8060x10 ⁰	1.0000	9.8060x10 ⁻¹	9.678x10 ⁻¹	2.0482x10 ³	3.2809x10 ¹
bar	1.4504x10 ¹	4.0147x10 ²	1.0197x10 ³	2.9530x10 ¹	7.5006x10 ²	1.0000x10 ⁶	1.0000x10 ⁰	1.0197	1.0000	9.8692x10 ⁻¹	2.0885x10 ³	3.3456x10 ¹
atm. (An)	1.4696x10 ¹	4.0679x10 ²	1.0333x10 ³	2.9921x10 ¹	7.6000x10 ²	1.0133x10 ⁶	1.0133x10 ⁰	1.0332	1.0113	1.0000	2.1162x10 ³	3.3900x10 ¹
lb./ft. ²	6.9445x10 ⁻³	1.9223x10 ⁻¹	4.882x10 ⁻¹	1.4139x10 ⁻²	3.591x10 ⁻¹	4.7880x10 ²	4.7880x10 ⁰	4.8824x10 ⁻⁴	4.7880x10 ⁻⁴	4.7254x10 ⁻⁴	1.0000	1.6019x10 ⁻²
ft H ₂ O (at +39.2°F)	4.3352x10 ⁻¹	1.2000x10 ¹	3.0480x10 ¹	8.826x10 ⁻¹	2.2419x10 ¹	2.9890x10 ⁴	2.9890x10 ⁰	3.0479x10 ⁻²	2.9890x10 ⁻²	2.9499x10 ⁻²	6.2427x10 ¹	1.0000

← Multiply Given Number of

Decimal and Millimeter Equivalents of Fractions

Fractions	Inches		Inches		Inches		Inches		Inches		Inches	
	Decimals	mm	Fractions	Decimals	Fractions	Decimals	Fractions	Decimals	Fractions	Decimals	Fractions	Decimals
1/64	.015625	.397	17/64	.65625	6.747	.515625	33/64	.515625	13.097	49/64	.765625	19.447
1/32	.03125	.794	9/32	.28125	7.144	.53125	17/32	.53125	13.494	25/32	.78125	19.844
3/64	.046875	1.191	19/64	.296875	7.541	.546875	35/64	.546875	13.891	51/64	.796875	20.241
1/16	.0625	1.588	5/16	.3125	7.938	.5625	9/16	.5625	14.288	13/16	.8125	20.638
5/64	.078125	1.984	21/64	.328125	8.334	.578125	37/64	.578125	14.684	53/64	.828125	21.034
3/32	.09375	2.381	11/32	.34375	8.731	.59375	19/32	.59375	15.081	27/32	.83475	21.431
7/64	.109375	2.778	23/64	.359375	9.128	.609375	39/64	.609375	15.478	55/64	.859375	21.828
1/8	.125	3.175	3/8	.375	9.525	.625	5/8	.625	15.875	7/8	.875	22.225
9/64	.140625	3.572	25/64	.390625	9.922	.640625	41/64	.640625	16.272	57/64	.890625	22.622
5/32	.15625	3.969	13/32	.40625	10.319	.65625	21/32	.65625	16.669	29/32	.90625	23.019
11/64	.171875	4.366	27/64	.421875	10.716	.671875	43/64	.671875	17.066	59/64	.921875	23.416
3/16	.1875	4.763	7/16	.4375	11.113	.6875	11/16	.6875	17.463	15/16	.9375	23.813
13/64	.203125	5.159	29/64	.453125	11.509	.703125	45/64	.703125	17.859	61/64	.953125	24.209
7/32	.21875	5.556	15/32	.46875	11.906	.71875	23/32	.71875	18.256	31/32	.96875	24.606
15/64	.234375	5.953	31/64	.484375	12.303	.734375	47/64	.734375	18.653	63/64	.984375	25.003
1/4	.250	6.350	1/2	.500	12.700	.750	3/4	.750	19.050	1	1.000	25.400

Appendix A Conversion Charts

Units of Length	Multiply units in left column by proper factor below							
	in.	ft.	yd.	mile	mm	cm	m	km
1 inch	1	0.0833	0.0278	-	25.4	2.540	0.0254	-
1 foot	12	1	0.3333	-	304.8	30.48	0.3048	-
1 yard	36	3	1	-	914.4	91.44	0.9144	-
1 mile	-	5280	1760	1	-	-	1609.3	1.609
1 millimeter	0.0394	0.0033	-	-	1	0.100	0.001	-
1 centimeter	0.3937	0.0328	0.0109	-	10	1	0.01	-
1 meter	39.37	3.281	1.094	-	1000	100	1	0.001
1 kilometer	-	3281	1094	0.6214	-	-	1000	1

(1 micron = 0.001 millimeter)

Units of Weight	Multiply units in left column by proper factor below						
	grain	oz.	lb.	ton	gram	kg	metric ton
1 grain	1	-	-	-	0.0648	-	-
1 ounce	437.5	1	0.0625	-	28.35	0.0283	-
1 pound	7000	16	1	0.0005	453.6	0.4536	-
1 ton	-	32,000	2000	1	-	907.2	0.9072
1 gram	15.43	0.0353	-	-	1	0.001	-
1 kilogram	-	35.27	2.205	-	1000	1	0.001
1 metric ton	-	35,274	2205	1.1023	-	1000	1

Units of Density	Multiply units in left column by proper factor below				
	lb./in. ³	lb./ft. ³	lb./gal.	g/cm ³	g/liter
1 pound/in. ³	1	1728	231.0	27.68	27,680
1 pound/ft. ³	-	1	0.1337	0.0160	16.019
1 pound/gal.	0.00433	7.481	1	0.1198	119.83
1 gram/cm ³	0.0361	62.43	8.345	1	1000.0
1 gram/liter	-	0.0624	0.00835	0.001	1

Units of Area	Multiply units in left column by proper factor below						
	in. ²	in. ²	acre	mile ²	cm ²	m ²	hectare
1 inch ²	1	1	-	-	6.452	-	-
1 foot ²	144	144	-	-	929.0	0.0929	-
1 acre	-	-	1	0.0016	-	4047	0.4047
1 mile ²	-	-	640	1	-	-	259.0
1 centimeter ²	0.1550	0.1550	-	-	1	0.0001	-
1 meter ²	1550	1550	-	-	10,000	1	-
1 hectare	-	-	2.471	-	-	10,000	1

Units of Volume	Multiply units in left column by proper factor below							
	in. ³	ft. ³	yd. ³	cm. ³	meter ³	liter	U.S. gal.	Imp. gal.
1 inch ³	1	-	-	16.387	-	0.0164	-	-
1 foot ³	1728	1	0.0370	28,317	0.0283	28.32	7.481	6.229
1 yard ³	46,656	27	1	-	0.7646	764.5	202.0	168.2
1 centimeter ³	0.0610	-	-	1	-	0.0010	-	-
1 meter ³	61,023	35.31	1.308	1,000,000	1	999.97	264.2	220.0
1 liter	61.025	0.0353	-	1000.028	0.0010	1	0.2642	0.2200
1 U.S. gallon	231	0.1337	-	3785.4	-	3.785	1	0.8327
1 Imp. gallon	277.4	0.1605	-	4546.1	-	4.546	1.201	1

Appendix A

Conversion Charts

Units of Pressure	Multiply units in left column by proper factor below							
	lbs./in. ²	lb./ft. ²	Int. etc.	kg/cm ²	mm Hg at 32°F	in. Hg at 32°F	ft. water at 39.2°F	kPa
lb./in. ²	1	144	-	0.0703	51.713	2.0359	2.307	6.894
lb./ft. ²	0.00694	1	-	-	0.3591	0.01414	0.01602	0.04788
Int. etc.	14.696	2116.2	1	1.0333	760	29.921	33.90	-
kg/cm ²	14.223	2048.1	0.9678	1	735.56	28.958	32.81	98.066
mm Hg	0.0193	2.785	-	-	1	0.0394	0.0446	0.1333
in Hg	0.4912	70.73	0.0334	0.0345	25.400	1	1.133	3.386
ft H ₂ O	0.4335	62.42	-	0.0305	22.418	0.8826	1	2.988
kPa	0.00145	20.89	-	0.010169	7.5006	0.2953	0.3346	1

Units of Energy	Multiply units in left column by proper factor below					
	ft.-lb.	BTU	g. cal.	Joule	kw-hr.	hp-hr.
1 foot-pound	1	0.001285	0.3240	1.3556	-	-
1 BTU	778.2	1	252.16	1054.9	-	-
1 gram calorie	3.0860	0.003966	1	4.1833	-	-
1 Int. Joule	0.7377	0.000948	0.2390	1	-	-
1 Int. kilowatt-hour	2,655,656	3412.8	860,563	-	1	1.3412
1 horsepower-hour	1,980,000	2544.5	641,617	-	0.7456	1

Units of Specific Pressure	Multiply units in left column by proper factor below				
	Absolute Joule/g	Int. Joule/g	cal/g	Int. cal/g	BTU/lb.
1 absolute Joule/gram	1	0.99984	0.23901	0.23885	0.42993
1 Int. Joule/gram	1.000165	1	0.23904	0.23892	0.43000
1 calorie/gram	4.1840	4.1833	1	0.99935	1.7988
1 int. calorie/gram	4.1867	4.1860	1.00065	1	1.8000
1 BTU/lb.	2.3260	2.3256	0.55592	0.55556	1

Units of Power (rates of energy use)	Multiply units in left column by proper factor below							
	hp	watt	kw	BTU/min.	ft.-lb./sec.	ft.-lb./min.	g. cal/sec.	metric hp
1 horsepower	1	75.7	0.7475	42.41	550	33.000	178.2	1.014
1 watt	-	1	0.001	0.0569	0.7376	44.25	0.2390	0.00136
1 kilowatt	1.3410	1000	1	56.88	737.6	44,254	239.0	1.360
1 BTU per minute	-	-	-	1	12.97	778.2	4.203	0.0239
1 metric hp	0.9863	735.5	0.7355	41.83	542.5	32.550	175.7	1

Units of Refrigeration	Multiply units in left column by proper factor below				
	BTU (IT) /min.	BTU (IT) /hr.	kg cal/hr.	ton(U.S.)comm	ton (Brit.) comm
1 ton (U.S.) comm	200	12,000	3025.9	1	0.8965
1 ton (Brit.) comm	223.08	13,385	3375.2	1.1154	1

NOTE: BTU is International Steam Table BTU (IT).

Conversion Charts

Temperature Conversion									
°F	°C	°F	°C	°F	°C	°F	°C	°F	°C
-459.4	-273	1	-17.2	61	16.1	300	149	900	482
-450	-268	2	-16.7	62	16.7	310	154	910	488
-440	-262	3	-16.1	63	17.2	320	160	920	493
-430	-257	4	-15.6	64	17.8	330	166	930	499
-420	-251	5	-15.0	65	18.3	340	171	940	504
-410	-246	6	-14.4	66	18.9	350	177	950	510
-400	-240	7	-13.9	67	19.4	360	182	960	516
-390	-234	8	-13.3	68	20.0	370	188	970	521
-380	-229	9	-12.8	69	20.6	380	193	980	527
-370	-223	10	-12.2	70	21.1	390	199	990	532
-360	-218	11	-11.7	71	21.7	400	204	1000	538
-350	-212	12	-11.1	72	22.2	410	210	1020	549
-340	-207	13	-10.6	73	22.8	420	215	1040	560
-330	-201	14	-10.0	74	23.3	430	221	1060	571
-320	-196	15	-9.4	75	23.9	440	227	1080	582
-310	-190	16	-8.9	76	24.4	450	232	1100	593
-300	-184	17	-8.3	77	25.0	460	238	1120	604
-290	-179	18	-7.8	78	25.6	470	243	1140	616
-280	-173	19	-7.2	79	26.1	480	249	1160	627
-273	-169	20	-6.7	80	26.7	490	254	1180	638
-270	-168	21	-6.1	81	27.2	500	260	1200	649
-260	-162	22	-5.6	82	27.8	510	266	1220	660
-250	-157	23	-5.0	83	28.3	520	271	1240	671
-240	-151	24	-4.4	84	28.9	530	277	1260	682
-230	-146	25	-3.9	85	29.4	540	282	1280	693
-220	-140	26	-3.3	86	30.0	550	288	1300	704
-210	-134	27	-2.8	87	30.6	560	293	1350	732
-200	-129	28	-2.2	88	31.1	570	299	1400	760
-190	-123	29	-1.7	89	31.7	580	304	1450	788
-180	-118	30	-1.1	90	32.2	590	310	1500	816
-170	-112	31	-0.6	91	32.8	600	316	1550	843
-160	-107	32	0.0	92	33.3	610	321	1600	871
-150	-101	33	0.6	93	33.9	620	327	1650	899
-140	-96	34	1.1	94	34.4	630	332	1700	927
-130	-90	35	1.7	95	35.0	640	338	1750	954
-120	-84	36	2.2	96	35.6	650	343	1800	982
-110	-79	37	2.8	97	36.1	660	349	1850	1010
-100	-73	38	3.3	98	36.7	670	354	1900	1038
-90	-68	39	3.9	99	37.2	680	360	1950	1066
-80	-62	40	4.4	100	37.8	690	366	2000	1093
-70	-57	41	5.0	110	43	700	371	2050	1121
-60	-51	42	5.6	120	49	710	377	2100	1149
-50	-46	43	6.1	130	54	720	382	2150	1177
-40	-40	44	6.7	140	60	730	388	2200	1204
-30	-34	45	7.2	150	66	740	393	2250	1232
-20	-29	46	7.8	160	71	750	399	2300	1260
-10	-23	47	8.3	170	77	760	404	2350	1288
0	-17.8	48	8.9	180	82	770	410	2400	1316
		49	9.4	190	88	780	416	2450	1343
		50	10.0	200	92	790	421	2500	1371
		51	10.6	210	99	800	427	2550	1399
		52	11.1	212	100	810	432	2600	1427
		53	11.7	220	104	820	438	2650	1454
		54	12.2	230	110	830	443	2700	1482
		55	12.8	240	116	840	449	2750	1510
		56	13.3	250	121	850	454	2800	1538
		57	13.9	260	127	860	460	2850	1566
		58	14.4	270	132	870	466	2900	1593
		59	15.0	280	138	880	471	2950	1621
		60	15.6	290	143	890	477	3000	1649

The following formulas may also be used for converting Celsius or Fahrenheit degrees into the other scales.

Degrees Celsius $^{\circ}\text{C} = \frac{5}{9} (^{\circ}\text{F} - 32)$

Degrees Fahr. $^{\circ}\text{F} = \frac{9}{5} ^{\circ}\text{C} + 32$

Degrees Kelvin $^{\circ}\text{T} = ^{\circ}\text{C} + 273.2$

Degrees Rankine $^{\circ}\text{R} = ^{\circ}\text{F} + 459.7$

Double Containment Material Recommendation Checklist

Project Name: _____

Anticipated Start Date: _____

Please answer the following questions to help determine the best system for your particular needs.

Fluid to be transported: _____	
Chemical Concentration: _____	
Working Pressure: _____	
Design Pressure min./max.: _____	
Working Temperature: _____	
Design Temperature min./max.: _____	
Carrier Pipe Size: _____	
Preferred Carrier Piping Material: _____	
Preferred Containment Piping Material: _____	
Test Method Carrier: _____	
Test Method Containment: _____	
Test Pressure Carrier: _____	
Test Pressure Containment: _____	
Type of Installation	Leak Detection
<input type="checkbox"/> Underground	Guardian Standard <input type="checkbox"/> Yes <input type="checkbox"/> No
<input type="checkbox"/> Above-Ground	Other: Please specify _____
<input type="checkbox"/> Combination	_____
Special Requirements/Conditions: _____ _____ _____ _____	

For firm quotation, please furnish line drawing or blueprints for system with approximate dimensional information or bill of material.

Company: _____ Phone: _____

Company Contact: _____ Distributor: _____

Guardian Salesperson: _____ Date: _____



Project Start-Up Checklist

Start-Up Date: _____

A: GENERAL INFORMATION

Project Name: _____

End-User/Owner: _____

Consulting Engineer: _____

Installing Contractor: _____

Type of Material: _____

B: STORED CONDITIONS

Pipe: _____

Fittings: _____

Closure Coupling: _____

Temperature Conditions: _____

General Appearance: _____

C: INSTALLATION CONDITIONS

Weather Good Poor _____ Temp

Remarks _____

D: INSTALLATION PROCEDURES

1. Have all IPEX product installers been trained on installation procedures?

Yes No

Rep. Initials _____ Cont. Initials _____

2. Project Start-up Training

a. Installation Jointing Method

- Solvent Cementing
- Metal
- FRP
- Other

b. Where held:

- On-site
- Contractor Shop
- Indoors
- Outdoors

c. Application

- Above-ground
- Below ground

Remarks _____

IPEX Representative Project Start-up Assessment:

Remarks: _____

Field Report: _____

IPEX Representative: _____

NOTES

NOTES

NOTES

SALES AND CUSTOMER SERVICE

IPEX Inc.

Toll Free: (866) 473-9462

ipexna.com

About IPEX by Aliaxis

As leading suppliers of thermoplastic piping systems, IPEX by Aliaxis provides our customers with some of the world's largest and most comprehensive product lines. All IPEX by Aliaxis products are backed by more than 50 years of experience. With state-of-the-art manufacturing facilities and distribution centers across North America, we have earned a reputation for product innovation, quality, end-user focus and performance.

Markets served by IPEX by Aliaxis include:

- Electrical systems
- Telecommunications and utility piping systems
- Industrial process piping systems
- Municipal pressure and gravity piping systems
- Plumbing and mechanical piping systems
- Electrofusion systems for gas and water
- Industrial, plumbing and electrical cements
- Irrigation systems
- PVC, CPVC, PP, PVDF, PE, ABS, and PEX pipe and fittings

Products manufactured by IPEX Inc.

Encase™, Guardian™, CustomGuard®, Centra-Guard™, Neutratanke®, Clear-Guard™ and Xirtec® are trademarks used under license.

Xirtec® CPVC piping systems are made with Corzan® CPVC compounds. Corzan® is a registered trademark of the Lubrizol Corporation.

This literature is published in good faith and is believed to be reliable. However it does not represent and/or warrant in any manner the information and suggestions contained in this brochure. Data presented is the result of laboratory tests and field experience.

A policy of ongoing product improvement is maintained. This may result in modifications of features and/or specifications without notice.

