

Submittal Data Sheet



Job or Customer:

Engineer:

Contractor:

Submitted by: Date

Approved by: Date

Order No: Date

Specification:

< STANDARDS >



ASTM F1412
ASTM D 4101
ASTM D 635

Neutralization of waste is necessary to protect the environment as well as attached piping systems. Ideally suited for this application, polypropylene and polyethylene tanks are a lightweight, durable and cost effective means of neutralizing this waste.

Depending upon the effluent content, high density polyethylene tanks may be used at temperatures up to 140°F. Polypropylene tanks may be used at temperatures up to 212°F. To complete the neutralization system, equipment can be supplied that will monitor Neutrasystem 2 the waste exiting the tanks to ensure equipment is performing as intended, and alert personnel if there are system problems, such as improper neutralization or flow problems.

ADDITIONAL CORROSIVE WASTE PRODUCTS

FLOWAY™

ENFIELD™

PLENUMLINE™

LABLINE®

Encase™

NEUTRATANK®
NEUTRALIZATION TANKS

tank availability

Cylindrical			Rectangular		
Sizes (gal.)	Polyethylene	Polypropylene	Sizes (gal.)	Polyethylene	Polypropylene
5	x		2	x	
7		x	5	x	
15	x	x	15	x	x
30	x	x	30	x	x
55	x	x	55	x	x
100	x	x	115	x	x
150	x	x	150	x	
200	x	x	215	x	
275	x	x	265	x	
360	x	x	400	x	
500	x	x	540	x	
700	x		670	x	
1000	x				
1250	x				
2000	x				

NOTE: Both polyethylene and polypropylene tanks can be fiberglass wrapped

Tank Specifications

Cylindrical Tanks

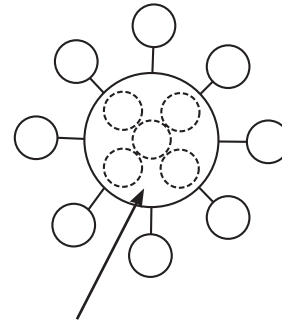
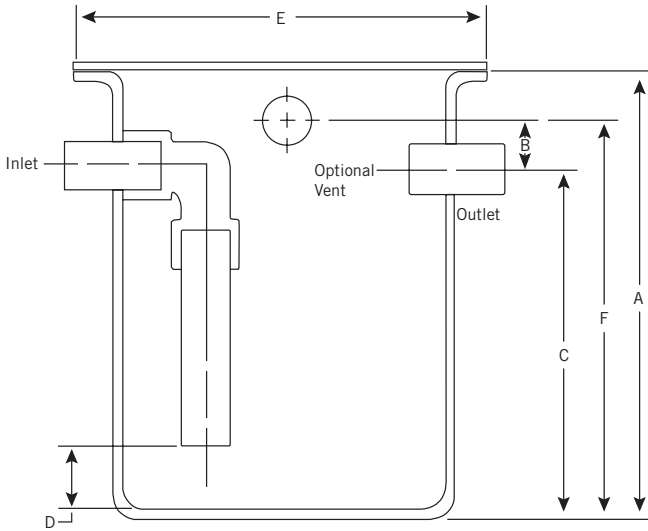

Threaded cover location, if applicable. Cover is centered on 100 gallon and smaller tanks

Mark desired location of connections by inserting an "I" for inlet, "O" for outlet and "V" for vent in the diagram.

Also indicate an "X" at the approximate location of threaded cover (if applicable).

Gal.	Dia. (in)	A (in)	B (in)	C (in)	D (in)	E (in)	F (in)	Extension Height (in)		Specify Inlet/Outlet size (in)	Specify Vent size (in)
								Non-adjustable Extension	Variable Extension		
*5	11	14	2	10.5	2	15.5	12	6 to 9	6 to 36		
**7	11	21	2	16	2	12	18	6 to 9	6 to 36		
15	18	15	2	10	2	21.5	12	6 to 14	6 to 36		
30	18	29	2	22	3	23	24	6 to 24	6 to 36		
55	22	36	2	27	3	24.25	29	6 to 31	6 to 36		
100	28	42	2	36	4	32	38	6 to 35	6 to 36		
150	31	48	2	38	6	36.5	40	6 to 43	6 to 36		
200	36	48	2	38	6	40.5	40	6 to 43	6 to 36		
275	42	48	2	38	6	47	40	6 to 42	6 to 36		
360	48	48	2	38	6	51	40	6 to 42			
500	52	60	2	52	6	56	54	6 to 54			
*700	55	70	2	60	6	60	62	6 to 62			
*1000	66	72	2	62	6	72	64	6 to 64			
*1250	69	84	2	72	8	76	74	6 to 78			
*2000	84	84	2	72	8	91	74	6 to 78			

* Available only in HDPE ** Available only in PP

NOTE: Custom sized tanks available upon request. Please contact IPEX for details.

NOTE: For vehicular traffic applications, IPEX strongly recommends that tanks are installed below grade with access to the tank vault via DOT approved manhole covers.

TANK SPECIFICATIONS

MATERIAL

- Polypropylene w/no re-reinforcement
- Polyethylene w/no re-reinforcement
- Polypropylene w/FRP Wrap (15 gal. & >)
- Polyethylene w/FRP Wrap (15 gal. & >)

TANK COVERS

NON-LOAD BEARING

- Standard Bolted Domed (not available in PP)
- HD Bolted Flat

LOAD BEARING

- 1/8" Smooth Finish Carbon Steel Pedestrian Traffic Cover
- 1/4" Diamond Finish Carbon Steel Pedestrian Traffic Cover

EXTENSION OPTIONS

- Non-Adjustable Extension™
- Variable Extension™

TANK EXTENSION

- Extension Height _____" (measured from top of standard tank)

ACCESS PORTS

- 8" Threaded Access Port
- 16" Threaded Access Port
- 22" Threaded Access Port

PIPE CONNECTIONS

- | | | | |
|-------------------------------------|--------------------------|--------------------------|--------------------------|
| | Inlet/Outlet/Vent | | |
| <input type="checkbox"/> Plain End | <input type="checkbox"/> | <input type="checkbox"/> | <input type="checkbox"/> |
| <input type="checkbox"/> Female Thd | <input type="checkbox"/> | <input type="checkbox"/> | <input type="checkbox"/> |
| <input type="checkbox"/> Male Thd | <input type="checkbox"/> | <input type="checkbox"/> | <input type="checkbox"/> |
| <input type="checkbox"/> Flanged | <input type="checkbox"/> | <input type="checkbox"/> | <input type="checkbox"/> |

ACCESSORIES

- Inlet Flow Distributor
- High/Low Level Alarm
 - Top Mount
 - Side Mount
- Limestone Chips, Qty of bags _____

Tank Specifications

Rectangular Tanks

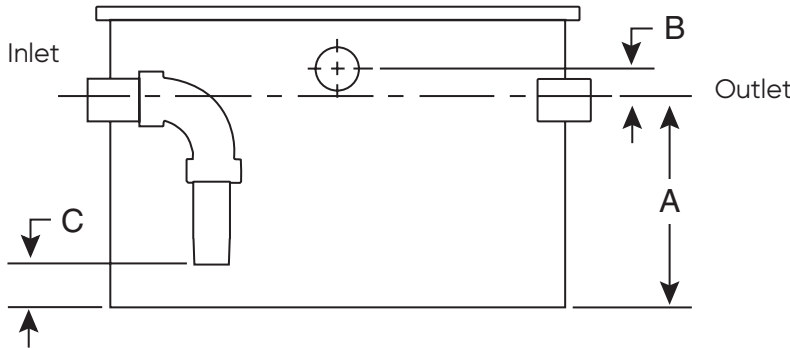

Mark desired location of connections by inserting an "I" for inlet, "O" for outlet and "V" for vent in the diagram. Also indicate an "X" at the approximate location of threaded cover (if applicable).

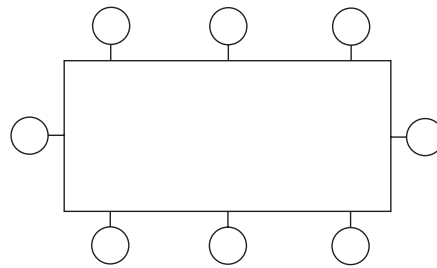

Gal.	L x W x H (in)	A (in)	B (in)	C (in)	Extension Height (in) Non-Adjustable	Specify Inlet/Outlet size (in)	Specify Vent size (in)
*2	8 x 8 x 8	5	1.5	2	n/a	1-1/2	
*5	10 x 16 x 8	5	1.5	2	4		
15	12 x 24 x 12	7	2	4	6 to 8		
30	12 x 24 x 24	18	2	4	6 to 20		
55	24 x 30 x 18	12	2	4	6 to 12		
115	30 x 30 x 30	24	2	4	6 to 24		
*150	24 x 48 x 30	24	2	4	6 to 24		
*215	36 x 36 x 42	36	2	4	6 to 36		
*265	36 x 72 x 24	18	2	4	6 to 20		
*400	36 x 72 x 36	30	2	4	6 to 30		
*540	36 x 72 x 48	42	2	4	6 to 42		
*670	36 x 72 x 60	54	2	4	6 to 54		

* Available only in HDPE

NOTE: Custom sized tanks available upon request. Please contact IPEX for details.

NOTE: For vehicular traffic applications, IPEX strongly recommends that tanks are installed below grade with access to the tank vault via DOT approved manhole covers.

TANK SPECIFICATIONS

MATERIAL

- Polypropylene w/no re-reinforcement
- Polyethylene w/no re-reinforcement
- Polypropylene w/FRP Wrap (15 gal. & >)
- Polyethylene w/FRP Wrap (15 gal. & >)

TANK COVERS

NON-LOAD BEARING

- Standard Bolted Domed (not available in PP)
- HD Bolted Flat

LOAD BEARING

- 1/8" Smooth Finish Carbon Steel Pedestrian Traffic Cover
- 1/4" Diamond Finish Carbon Steel Pedestrian Traffic Cover

EXTENSION OPTIONS

- Non-Adjustable Extension™
- Variable Extension™

TANK EXTENSION

- Extension Height _____" (measured from top of standard tank)

ACCESS PORTS

- 8" Threaded Access Port
- 16" Threaded Access Port
- 22" Threaded Access Port

PIPE CONNECTIONS

- | | | | |
|-------------------------------------|--------------------------|--------------------------|--------------------------|
| | Inlet/Outlet/Vent | | |
| <input type="checkbox"/> Plain End | <input type="checkbox"/> | <input type="checkbox"/> | <input type="checkbox"/> |
| <input type="checkbox"/> Female Thd | <input type="checkbox"/> | <input type="checkbox"/> | <input type="checkbox"/> |
| <input type="checkbox"/> Male Thd | <input type="checkbox"/> | <input type="checkbox"/> | <input type="checkbox"/> |
| <input type="checkbox"/> Flanged | <input type="checkbox"/> | <input type="checkbox"/> | <input type="checkbox"/> |

ACCESSORIES

- Inlet Flow Distributor
- High/Low Level Alarm
 - Top Mount
 - Side Mount
- Limestone Chips, Qty of bags _____

Maintenance

The size of the neutralization tank is a function of the number of sinks and drains that are discharged into the system. According to ASPE, tanks are sized to provide a minimum “dwell time” of 2 1/2 to 3 hours. Based on this dwell time, ASPE has developed a sizing table which is summarized and can be used as a guide in selecting the proper size tank. Tanks should not be sized based on the number of sinks or drains alone. Certain types of waste may require particular needs and may not fall within the standard sink to tank ratio. Other factors that can affect the tank size are not limited to, but inclusive of: the amount of flow through the system, the type of chemicals and the size of the system piping. A qualified engineer should make the final determination of the tank size.

Maintenance

The limestone chips supplied by IPEX are 1" to 3" in diameter and have a calcium carbonate content certified to be in excess of 90%. Water should always be added to the tank to help facilitate dilution. Limestone replacement should be performed at regular intervals. Typically, once every one to three years is sufficient, however, these intervals can be increased or decreased based upon application needs and performance. Factors affecting limestone replacement are waste flow rates, pH levels, and operating temperatures.

Note: There are many variables that affect neutralization and dilution of chemicals discharged through a system. Professional assistance should be employed in analyzing the effluent and the necessary maintenance service frequency.

Tank Size and Limestone Loading Chart

Number of sinks	Tank size in gallons	Limestone Loading for Neutralization (lbs)
2	5	50
4	15	125
8	30	250
16	55	500
30	100	1000
40	150	1500
60	200	2000
75	275	2500
110	360	3500
150	500	5250
215	700	8000
275	1000	10000
315	1250	12000
500	2000	18000

Installation

Neutratan Installation and Application Advice

1. Tanks must be placed on a flat, solid surface allowing uniform, full support to the tank bottom. Such surfaces may be basement floors, concrete pads or compact, stone-free sand beds.
2. When installed below ground, tanks should be placed in a concrete vault. Tanks should never be buried directly in the ground unless they are wrapped in Fiberglass. IPEX can supply fiberglass wrapped tanks upon request.
3. The tank itself must not be used to support manhole covers, traffic of any kind or heavy equipment.
4. Do not support the tank by inlet, outlet, vent or any connecting piping.
5. Do not place any weight on tank fittings or connecting piping.
6. Tanks must NOT be subjected to pressure or vacuum including hydro-testing.
7. Depending upon effluent content, HDPE tanks may be used at temperatures up to 140°F. Polypropylene tanks may be used at temperatures up to 212°F.
8. Where possible, fill the tank with water prior to introducing the limestone and media.
9. Tank insulation may be considered for outdoor installation in cold environments.

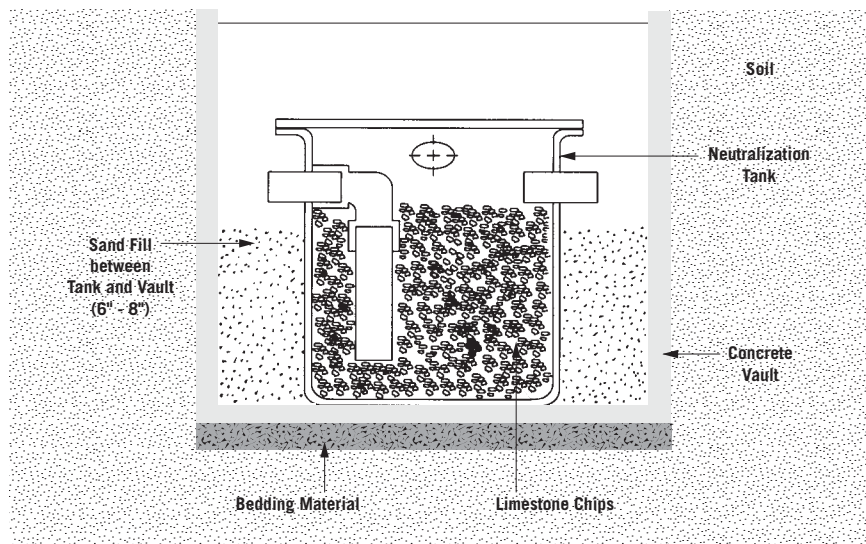

Tanks for Direct Burial

When concrete vaults are not possible or desirable, IPEX can manufacture tanks that are wrapped with fiberglass, eliminating the need for a concrete vault. Cylindrical and rectangular tanks larger than 5-gallon sizes can be fiberglass wrapped for direct burial applications.

About the IPEX Group of Companies

As leading suppliers of thermoplastic piping systems, the IPEX Group of Companies provides our customers with some of the world's largest and most comprehensive product lines. All IPEX products are backed by more than 50 years of experience. With state-of-the-art manufacturing facilities and distribution centers across North America, we have established a reputation for product innovation, quality, end-user focus and performance.

Markets served by IPEX group products are:

- Electrical systems
- Telecommunications and utility piping systems
- PVC, CPVC, PP, ABS, PEX, FR-PVDF and PE pipe and fittings (1/4" to 48")
- Industrial process piping systems
- Municipal pressure and gravity piping systems
- Plumbing and mechanical piping systems
- PE Electrofusion systems for gas and water
- Industrial, plumbing and electrical cements
- Irrigation systems

Products manufactured by IPEX Inc.

Encase™, Enfield™, Floway™, Labline®, Neutrasystem2™, Neutratanck®, and Plenumline™ are trademarks of IPEX Branding Inc.

This literature is published in good faith and is believed to be reliable. However, it does not represent and/or warrant in any manner the information and suggestions contained in this brochure. Data presented is the result of laboratory tests and field experience.

A policy of ongoing product improvement is maintained. This may result in modifications of features and/or specifications without notice.