

VR Series Piston Check Valves

Product Data Sheet



< STANDARDS >



ASTM D1784
ASTM D2464
ASTM D2466
ASTM D2467
ASTM F1498



ANSI B1.20.1
ANSI B16.5

The IPEX VR Piston Check Valve is an ideal solution for process back-flow prevention. These valves feature all PVC high performance components allowing for increased flow rate yet a low-return pressure for positive seal. With installation possible in both horizontal and vertical orientations, the top-entry design provides for simple in-line maintenance. VR Piston Check Valves are part of our complete systems of pipe, valves, and fittings, engineered and manufactured to our strict quality, performance, and dimensional standards.

VALVE AVAILABILITY

Body Material	PVC
Size Range	1/2" through 4"
Pressure	232 psi (1/2" to 1"), 150 psi (1-1/4" to 2"), 90 psi (3" to 4")
Seals	EPDM, or FPM
End Connections	Socket (IPS), Threaded (FNPT), Flanged (ANSI 150)

VR Series Piston Check Valves

Product Data Sheet

Sample Specification

1.0 Check Valves - VR

1.1 Material

- The valve body, end connectors, and unions shall be made of PVC compound which shall meet or exceed the requirements of cell classification 12454 according to ASTM D1784.

1.2 Seals

- The o-ring seals and shutter shall be made of EPDM.
- or The o-ring seals and shutter shall be made of FPM.

2.0 Connections

2.1 Socket style

- The IPS socket PVC end connectors shall conform to the dimensional standards ASTM D2466 and ASTM D2467.

2.2 Threaded style

- The female NPT threaded PVC end connectors shall conform to the dimensional standards ASTM D2464, ASTM F1498, and ANSI B1.20.1.

2.3 Flanged style

- The ANSI 150 flanged PVC end connectors shall conform to the dimensional standard ANSI B16.5..

3.0 Design Features

- Valve sizes 1/2" through 2" shall have true union ends.
- Valve sizes 3" through 4" shall have either socket or threaded ends.
- All valves shall be y-pattern globe style in design.
- All valves shall be gravity operated.
- The weight shall be totally encapsulated inside the piston.
- The valve shall function in both horizontal and vertical lines with no minimum column requirements.
- Servicing of the valves shall be possible without removal from the line.

3.1 Pressure Rating

- Valve sizes 1/2" through 1" shall be rated at 232 psi at 73°F.
- Flanged valve sizes 1/2" through 1" shall be rated at 150 psi at 73°F.
- Valve sizes 1-1/4" through 2" shall be rated at 150 psi at 73°F.
- Valve sizes 3" through 4" shall be rated at 90 psi at 73°F.

3.2 Markings

- All valves shall be marked to indicate size, material designation, and manufacturers name or trade mark.

3.3 Color Coding

- All PVC valves shall be color-coded dark gray.

- 4.0** All valves shall be Xirtec® PVC by IPEX or approved equal.

VR Series Piston Check Valves

Product Data Sheet

Valve Selection

Size (inches)	Body Material	O-ring Material	IPEX Part Number			Pressure Rating
			IPS Socket	FNPT Threaded	ANSI Flanged	
1/2	PVC	EPDM	053346	053879	232 psi for S/T	
		FPM	053289	053885		
3/4	PVC	EPDM	053347	053880		
		FPM	053290	053886		
1	PVC	EPDM	053348	053881		150 psi for F
		FPM	053291	053887		
1-1/4	PVC	EPDM	053349	053882	150 psi	
		FPM	053292	053888		
1-1/2	PVC	EPDM	053350	053883		
		FPM	053293	053889		
2	PVC	EPDM	053351	053884		90 psi
		FPM	053294	053890		
3	PVC	EPDM	053295	053352	053925	
4	PVC	EPDM	053296	053353	053926	

Note: Sizes 3" and 4" are not true union style.

Dimensions

IPS Socket Connections – Dimension (inches)

Size	d	L	Z	H	E	B	A _{MAX}
1/2	0.84	0.63	4.06	5.31	2.17	2.83	4.92
3/4	1.05	0.75	4.72	6.22	2.60	3.31	5.71
1	1.32	0.87	5.20	6.93	2.95	3.74	6.50
1-1/4	1.66	1.02	6.10	8.15	3.43	4.37	7.48
1-1/2	1.90	1.22	7.13	9.57	3.94	4.72	8.27
2	2.38	1.50	8.72	11.73	4.72	5.47	9.45

Female NPT Threaded Connections – Dimension (inches)

Size	R	L	Z	H	E	B	A _{MAX}
1/2	1/2-NPT	0.59	4.45	5.63	2.17	2.83	4.92
3/4	3/4-NPT	0.64	5.02	6.30	2.60	3.31	5.71
1	1-NPT	0.75	5.70	7.20	2.95	3.74	6.50
1-1/4	1-1/4-NPT	0.84	6.74	8.43	3.43	4.37	7.48
1-1/2	1-1/2-NPT	0.84	7.57	9.25	3.94	4.72	8.27
2	2-NPT	1.01	9.20	11.22	4.72	5.47	9.45

Size (inches):

- 1/2
- 3/4
- 1
- 1-1/4
- 1-1/2
- 2
- 3
- 4

Seals:

- EPDM
- FPM

End Connections:

- Socket (IPS)
- Threaded (FNPT)
- Flanged (ANSI 150)

IPEX Part Number:

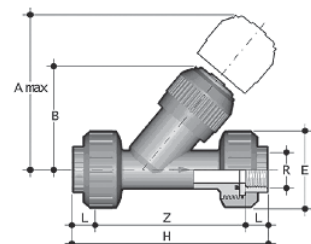
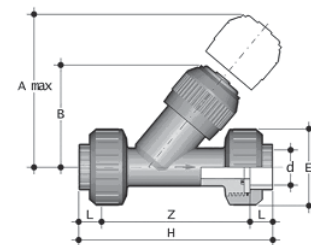

VR Series Piston Check Valves

Product Data Sheet

Dimensions

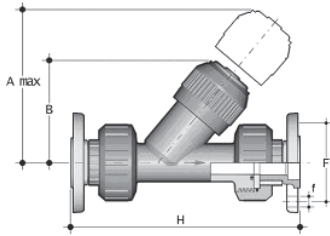

ANSI 150 Flanged (Vanstone) Connections – Dimension (inches)

Size	# holes	f	F	H	B	A _{MAX}
1/2	4	5/8	2-3/8	7.13	2.83	4.92
3/4	4	5/8	2-3/4	8.16	3.31	5.71
1	4	5/8	3-1/8	9.05	3.74	6.50
1-1/4	4	5/8	3-1/2	10.34	4.37	7.48
1-1/2	4	5/8	3-7/8	12.07	4.72	8.27
2	4	3/4	4-3/4	14.48	5.47	9.45

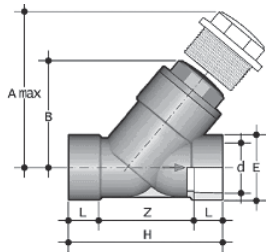

IPS Socket Connections – Dimension (inches)

Size	R	L	Z	H	E	B	AMAX
3	3.50	2.01	6.30	10.31	4.57	7.56	12.80
4	4.50	2.40	7.99	12.80	5.43	9.09	15.16

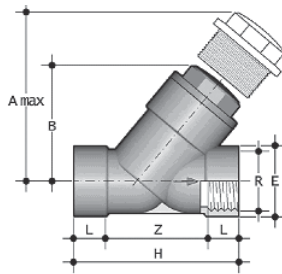

Female NPT Threaded Connections – Dimension (inches)

Size	R	L	Z	H	E	B	AMAX
3	3-NPT	1.31	7.69	10.31	4.57	7.56	12.80
4	4-NPT	1.55	9.70	12.80	5.43	9.09	15.16

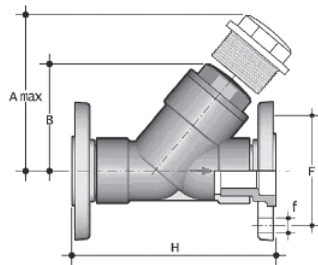

ANSI 150 Flanged (Vanstone) Connections – Dimension (inches)

Size	# holes	f	F	H	B	AMAX
3	4	3/4	6	12.81	7.56	12.80
4	8	3/4	7-1/2	15.62	9.09	15.16

Weights

Approximate Weight (lbs)

Size	IPS Socket	FNPT Threaded	ANSI Flanged
1/2	0.50	0.51	0.90
3/4	0.86	0.86	1.44
1	1.34	1.33	2.12
1-1/4	2.03	2.05	3.04
1-1/2	2.94	2.96	4.14
2	5.10	5.18	6.98
3	9.99	9.96	13.73
4	15.81	15.36	21.80

Pressure – Temperature Ratings

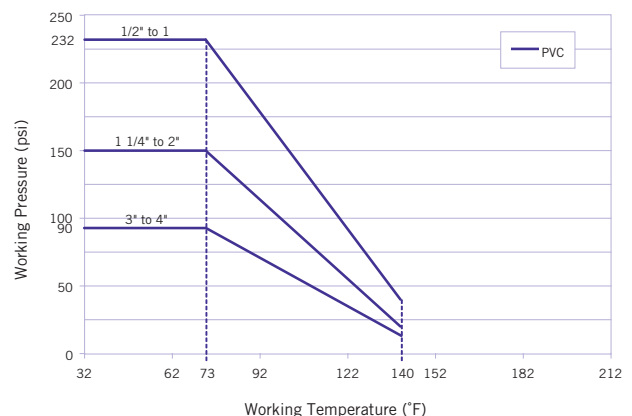

VR Series Piston Check Valves

Product Data Sheet

Flow Coefficients

Size	C _v
1/2	7.70
3/4	14.4
1	26.3
1-1/4	39.2
1-1/2	58.5
2	91.0
3	182
4	245

Pressure Loss Chart

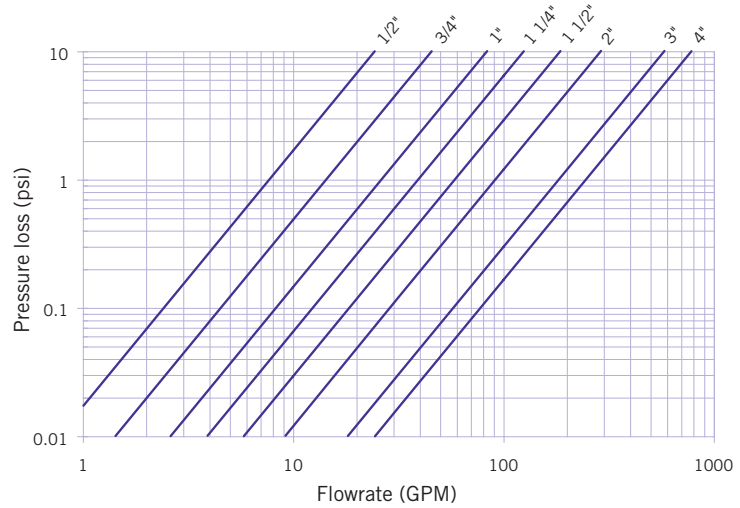

Minimum Back Pressure to Seal

Size (inches)	P (psi)
1/2	0.21
3/4	0.28
1	0.50
1-1/4	0.50
1-1/2	0.50
2	0.50
3	0.50
4	0.50

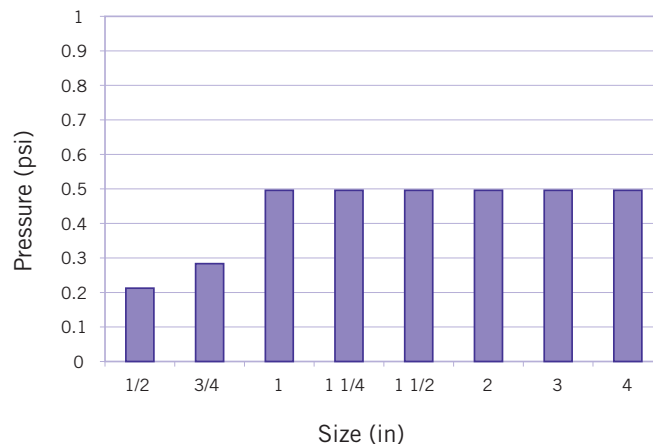

Minimum Pressure to Open

Size (inches)	P (psi)
1/2	0.12
3/4	0.13
1	0.20
1-1/4	0.25
1-1/2	0.26
2	0.30
3	0.32
4	0.35

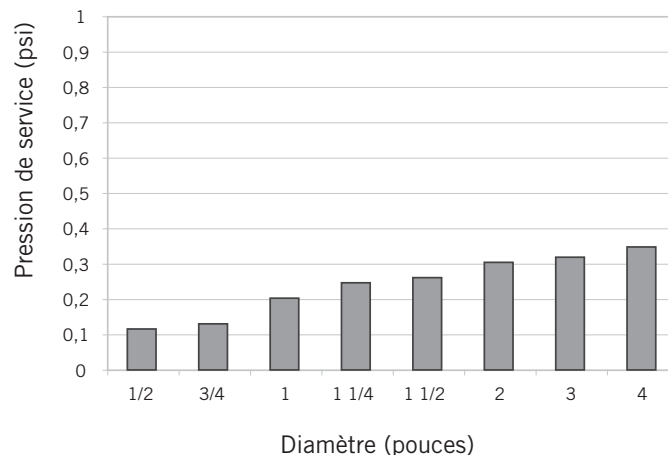

VR Series Piston Check Valves

Product Data Sheet

Components

Sizes 1/2" through 2"

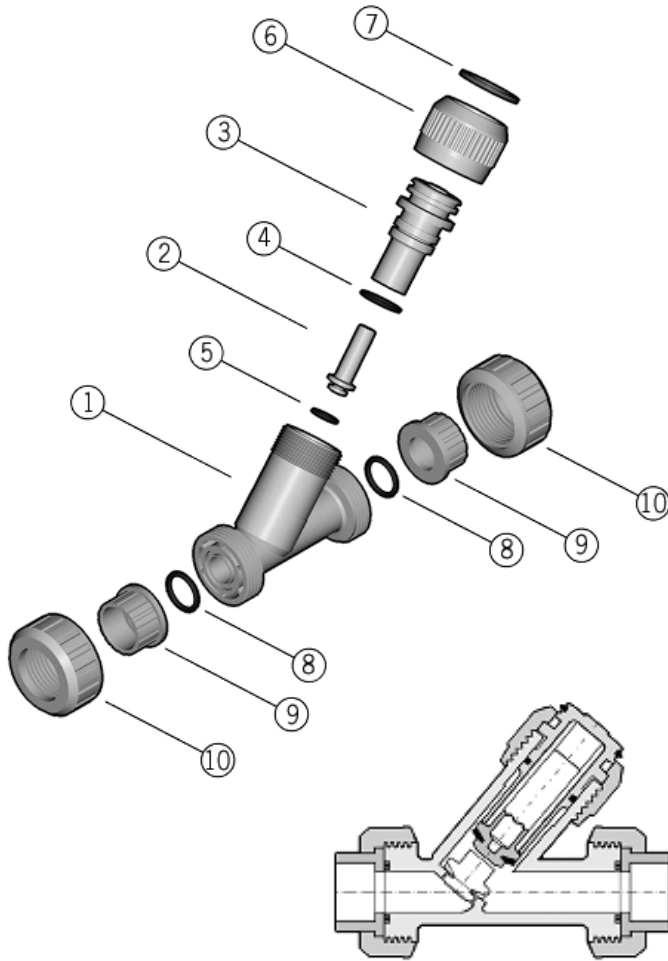

Sizes 3"

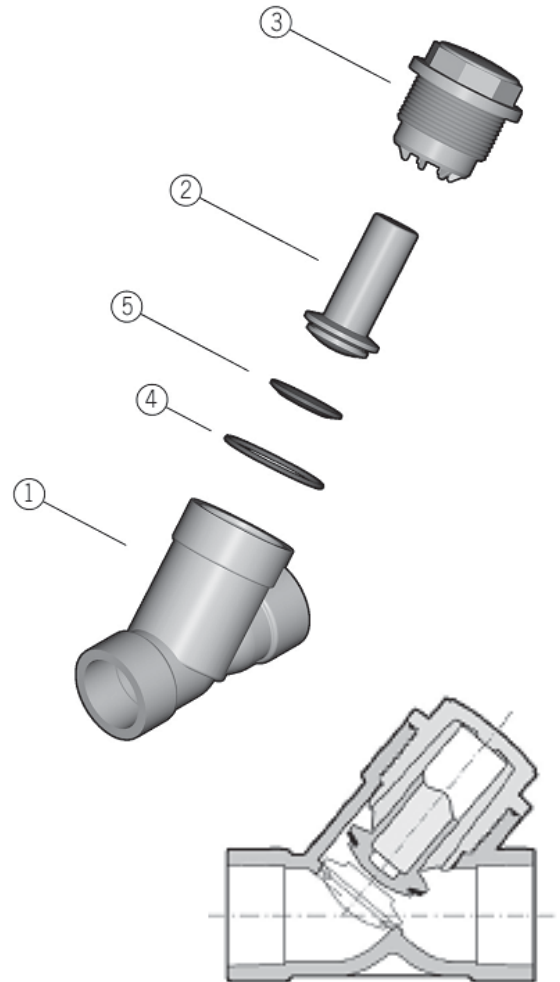

#	Component	Material	Qty
1	body	PVC	1
2	piston	PVC	1
3	bonnet	PVC	1
4	o-ring seal	EPDM or FPM	1
5	flat gasket	EPDM or FPM	1
6	lock nut	PVC	1
7	split ring	PVC	1
8	socket o-ring	EPDM or FPM	2
9	end connector	PVC	2
10	union nut	PVC	2

#	Component	Material	Qty
1	body	PVC	1
2	piston	PVC	1
3	bonnet	PVC	1
4	o-ring seal	EPDM or FPM	1
5	flat gasket	EPDM or FPM	1

VR Series Piston Check Valves

Product Data Sheet

Sizes 4"

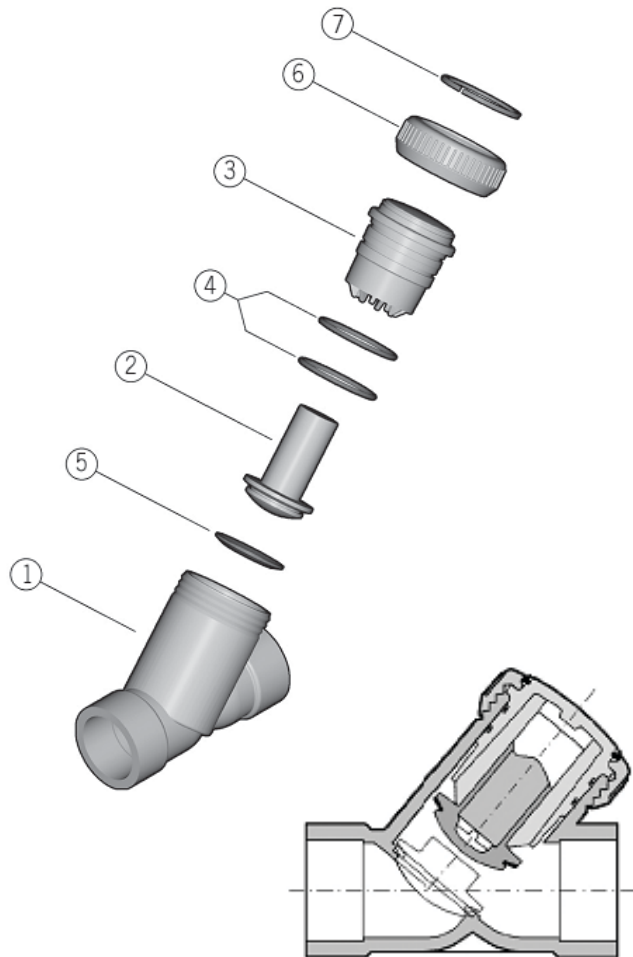

#	Component	Material	Qty
1	body	PVC	1
2	piston	PVC	1
3	bonnet	PVC	1
4	o-ring seal	EPDM or FPM	2
5	flat gasket	EPDM or FPM	1
6	lock nut	PVC	1
7	split ring	PVC	1

VR Series Piston Check Valves

Product Data Sheet

Installation Procedures

True Union Style

1. For socket and threaded style connections, remove the union nuts (part #10 on previous pages) and slide them onto the pipe. For flanged connections, remove the union nut / flange assemblies from the valve.
2. Please refer to the appropriate connection style sub-section:
 - a. For socket style, solvent cement the end connectors (9) onto the pipe ends. For correct joining procedure, please refer to the section entitled, "Joining Methods – Solvent Cementing" in the IPEX Industrial Technical Manual Series, "Volume I: Vinyl Process Piping Systems". **Be sure to allow sufficient cure time before continuing with the valve installation.**
 - b. For threaded style, thread the end connectors (9) onto the pipe ends. For correct joining procedure, please refer to the section entitled, "Joining Methods – Threading" in the IPEX Industrial Technical Manual Series, "Volume I: Vinyl Process Piping Systems".
 - c. For flanged style, join the union nut / flange assemblies to the pipe flanges. For correct joining procedure, please refer to the section entitled, "Joining Methods – Flanging" in the IPEX Industrial Technical Manual Series, "Volume I: Vinyl Process Piping Systems".
3. Ensure that the valve is in the correct orientation, and that the socket o-rings (8) are properly fitted in their grooves. Carefully place the valve in the system between the two end connections.
4. Tighten both union nuts and the lock nut (6). Hand tightening is typically sufficient to maintain a seal for the maximum working pressure. **Over-tightening may damage the threads on the valve body and/or the nut, and may even cause the nut to crack.**

Non True Union Style

1. Please refer to the appropriate connection style sub-section:
 - a. For socket style, ensure that the valve is in the correct orientation then solvent cement the end connections of the valve body (1) to the pipe ends. For correct joining procedure, please refer to the section entitled, "Joining Methods – Solvent Cementing" in the IPEX Industrial Technical Manual Series, "Volume I: Vinyl Process Piping Systems". **Be sure to allow sufficient cure time before continuing with the valve installation.**
 - b. For threaded style, ensure that the valve is in the correct orientation then thread the pipe ends into the valve body (1). For correct joining procedure, please refer to the section entitled, "Joining Methods – Threading" in the IPEX Industrial Technical Manual Series, "Volume I: Vinyl Process Piping Systems".
 - c. For flanged style, ensure that the valve is in the correct orientation then join to the pipe flanges. For correct joining procedure, please refer to the section entitled, "Joining Methods – Flanging" in the IPEX Industrial Technical Manual Series, "Volume I: Vinyl Process Piping Systems".
2. Ensure that the bonnet (3, size 3") or lock nut (6, size 4") is sufficiently tightened. Hand tightening is typically sufficient to maintain a seal for the maximum working pressure. **Over-tightening may damage the threads on the valve body and/or the nut, and may even cause the nut to crack.**

VR Series Piston Check Valves

Product Data Sheet

Disassembly

1. If removing the valve from an operating system, isolate the valve from the rest of the system. **Be sure to depressurize and drain the isolated branch and valve before continuing.**
2. For true union style, loosen both union nuts (10) and drop the valve out of the line. If retaining the socket o-rings (8), take care that they are not lost when removing the valve from the line.
3. For sizes 1/2" through 2" and 4":
 - a. Loosen the lock nut (6) – bonnet (3) assembly and remove from the valve body (1).
 - b. Remove the split ring (7) to separate the lock nut from the bonnet.
 - c. Remove the o-ring seal(s) (4) from the bonnet.
4. For size 3":
 - a. Loosen the bonnet (3) and remove from the valve body (1).
 - b. Remove the o-ring seal (4) from the groove on the valve body.
5. Remove the piston (2) from the valve body and then the flat gasket (5) from the piston.
6. The valve components can now be checked for problems and/or replaced.

Assembly

Note: Before assembling the valve components, it is advisable to lubricate the o-rings with a water soluble lubricant. **Be sure to consult the "IPEX Chemical Resistance Guide" and/or other trusted resources to determine specific lubricant-rubber compatibilities.**

1. Properly fit the flat gasket (5) in the groove on the piston (2) then insert into the valve body (1).
2. For sizes 1/2" through 2" and 4":
 - a. Properly fit the o-ring seal(s) (4) onto the bonnet.
 - b. Place the lock nut (6) over the bonnet (3) then fit the split ring (7) in the groove to lock in position.
 - c. Insert the lock nut (6) – bonnet (3) assembly into the valve body and tighten.
3. For size 3":
 - a. Properly fit the o-ring seal (4) in the groove on the valve body.
 - b. Tighten the bonnet (3) into the valve body.
4. For true union style, ensure that the socket o-rings (8) are properly fitted in their grooves, place the end connectors into the union nuts (10), then tighten onto the valve body.

VR Series Piston Check Valves

Product Data Sheet

Testing and Operating

The purpose of system testing is to assess the quality of all joints and fittings to ensure that they will withstand the design working pressure, plus a safety margin, without loss of pressure or fluid. Typically, the system will be tested and assessed in sub-sections as this allows for improved isolation and remediation of potential problems. With this in mind, the testing of a specific installed valve is achieved while carrying out a test of the overall system.

An onsite pressure test procedure is outlined in the IPEX Industrial Technical Manual Series, "Volume I: Vinyl Process Piping Systems" under the section entitled, "Testing". The use of this procedure should be sufficient to assess the quality of a valve installation. **In any test or operating condition, it is important to never exceed the pressure rating of the lowest rated appurtenance in the system.**

Important points:

- Never test thermoplastic piping systems with compressed air or other gases including air-over-water boosters.
- When testing, do not exceed the rated maximum operating pressure of the valve.
- Avoid the rapid closure of valves to eliminate the possibility of water hammer which may cause damage to the pipeline or the valve.

Please contact IPEX customer service and technical support with regard to any concern not addressed in this data sheet or the technical manual.

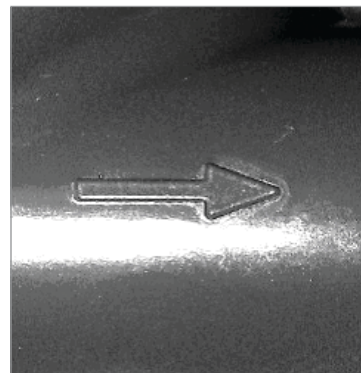

About the IPEX Group of Companies

As leading suppliers of thermoplastic piping systems, the IPEX Group of Companies provides our customers with some of the world's largest and most comprehensive product lines. All IPEX products are backed by more than 50 years of experience. With state-of-the-art manufacturing facilities and distribution centers across North America, we have established a reputation for product innovation, quality, end-user focus and performance.

Markets served by IPEX group products are:

- Electrical systems
- Telecommunications and utility piping systems
- Industrial process piping systems
- Municipal pressure and gravity piping systems
- Plumbing and mechanical piping systems
- Electrofusion systems for gas and water
- Industrial, plumbing and electrical cements
- Irrigation systems
- PVC, CPVC, PP, PVDF, PE, ABS, and PEX pipe and fittings

Xirtec® is a registered trademark used under license.

This literature is published in good faith and is believed to be reliable. However, it does not represent and/or warrant in any manner the information and suggestions contained in this brochure. Data presented is the result of laboratory tests and field experience.

A policy of ongoing product improvement is maintained. This may result in modifications of features and/or specifications without notice.