

SSE Series Spring Assisted Check Valves

Product Data Sheet



< STANDARDS >



ASTM D1784
ASTM D2464
ASTM D2466
ASTM D2467
ASTM F1498



ANSI B1.20.1
ANSI B16.5

The IPEX EasyFit SSE Series Spring Assisted Check Valves represent the latest innovation in thermoplastic valve manufacturing technology. The all new SSE complements our SXE ball check valves, which introduce an advanced method of installation, providing trouble free service for industrial, OEM and water service applications. The internal profile of the SSE, combined with the spring assisted contoured ball, gives the advantage of trouble-free vertical and horizontal installations, even if only very low backpressure is available. The innovative SSE EasyFit design features a custom labelling system, and the EasyFit multifunctional handle allows for union nut rotational control and safe blocked carrier tightening. SSE Spring Assisted Check Valves are part of our complete system of IPEX pipe, valves and fittings, engineered and manufactured to our strict quality, performance and dimensional standards.

VALVE AVAILABILITY

Body Material	PVC
Size Range	1/2" through 4"
Pressure	232 psi
Seals	EPDM or Fluoropolymer (FPM)
Spring Material	1/2" through 4" 316 Stainless Steel (SS), 1-1/4" through 4" PTFE Encapsulated 316SS 1/2" through 1" Hastelloy®
End Connections	Socket (IPS), Threaded (FNPT)

SSE Series Spring Assisted Check Valves

Product Data Sheet

Sample Specification

1.0 Check Valves – SSE

1.1 Material

- The valve body, ball, end connectors, and unions shall be made of PVC compound which shall meet or exceed the requirements of cell classification 12454 according to ASTM D1784.

1.2 Seals

- The o-ring seals shall be made of EPDM.
- or The o-ring seals shall be made of FPM.

1.3 Spring Material

- The spring material shall be made of 316SS.
- or The spring material shall be made of PTFE encapsulated 316SS.
- or The spring material shall be made of Hastelloy®.

2.0 Connections

2.1 Socket style

- The IPS socket PVC end connectors shall conform to the dimensional standards ASTM D2466 and ASTM D2467.

2.2 Threaded style

- The female NPT threaded PVC end connectors shall conform to the dimensional standards ASTM D2464, ASTM F1498, and ANSI B1.20.1.

3.0 Design Features

- The valve shall have true union ends.
- The valve cavity shall feature an optimized profile design to reduce pressure drop and improve the Cv value
- The valve body and union nuts shall have deep square style threads for increased strength.
- The Main-seal carrier shall be a safe blocked design and allow for safe disconnection of the union nuts for maintenance. The main-seal carrier shall be compatible with the EasyFit multifunctional handle for precise component tightening. (2-1/2" – 4" valves)
 - The union nuts shall be compatible with the EasyFit multifunctional handle and EasyFit Torque Wrench (1/2" – 2" valves) for precise tightening.
 - The valve shall have a transparent plug housing for use with EasyFit Labelling System for valve identification.

3.1 Pressure Rating

- All valves shall be rated at 232 psi at 73°F.
- All valves shall be suitable for use with liquids having a specific gravity less than 0.05 lb/in³.

3.2 Markings

- All valves shall be marked to indicate size, material designation, and manufacturers name or trade mark.

3.3 Color Coding

- All PVC valves shall be color-coded dark gray.

- 4.0 All valves shall be Xirtec® PVC by IPEX or approved equal.

SSE Series Spring Assisted Check Valves

Product Data Sheet

Valve Selection

Size (inches)	Body Material	Seal Material	Spring Material	Socket/Threaded		Socket	
				Product Code	Universal Number	Product Code	Universal Number
1/2	PVC	EPDM	316SS	052490	SSEBV103S	-	-
			Hastelloy	052152	SSEBV103H	-	-
			PTFE/316SS	-	-	-	-
		FPM	316SS	052499	SSEBV203S	-	-
			Hastelloy	052163	SSEBV203H	-	-
			PTFE/316SS	-	-	-	-
3/4	PVC	EPDM	316SS	052491	SSEBV104S	-	-
			Hastelloy	052153	SSEBV104H	-	-
			PTFE/316SS	-	-	-	-
		FPM	316SS	052500	SSEBV204S	-	-
			Hastelloy	052177	SSEBV204H	-	-
			PTFE/316SS	-	-	-	-
1	PVC	EPDM	316SS	052492	SSEBV105S	-	-
			Hastelloy	052154	SSEBV105H	-	-
			PTFE/316SS	-	-	-	-
		FPM	316SS	052501	SSEBV205S	-	-
			Hastelloy	052178	SSEBV205H	-	-
			PTFE/316SS	-	-	-	-
1-1/4	PVC	EPDM	316SS	052493	SSEBV106S	-	-
			Hastelloy	-	-	-	-
			PTFE/316SS	052347	SSEBV106P	-	-
		FPM	316SS	052502	SSEBV206S	-	-
			Hastelloy	-	-	-	-
			PTFE/316SS	052362	SSEBV206P	-	-
1-1/2	PVC	EPDM	316SS	052494	SSEBV107S	-	-
			Hastelloy	-	-	-	-
			PTFE/316SS	052348	SSEBV107P	-	-
		FPM	316SS	052503	SSEBV207S	-	-
			Hastelloy	-	-	-	-
			PTFE/316SS	052396	SSEBV207P	-	-
2	PVC	EPDM	316SS	052495	SSEBV108S	-	-
			Hastelloy	-	-	-	-
			PTFE/316SS	052358	SSEBV108P	-	-
		FPM	316SS	052504	SSEBV208S	-	-
			Hastelloy	-	-	-	-
			PTFE/316SS	052397	SSEBV208P	-	-
2-1/2	PVC	EPDM	316SS	-	-	052496	SSEAV109S
			Hastelloy	-	-	-	-
			PTFE/316SS	-	-	052359	SSEAV109P
		FPM	316SS	-	-	052505	SSEAV209S
			Hastelloy	-	-	-	-
			PTFE/316SS	-	-	052398	SSEAV209P
3	PVC	EPDM	316SS	-	-	052497	SSEAV110S
			Hastelloy	-	-	-	-
			PTFE/316SS	-	-	052360	SSEAV110P
		FPM	316SS	-	-	052506	SSEAV210S
			Hastelloy	-	-	-	-
			PTFE/316SS	-	-	052399	SSEAV210P
4	PVC	EPDM	316SS	-	-	052498	SSEAV111S
			Hastelloy	-	-	-	-
			PTFE/316SS	-	-	052361	SSEAV111P
		FPM	316SS	-	-	052507	SSEAV211S
			Hastelloy	-	-	-	-
			PTFE/316SS	-	-	052414	SSEAV211P

Body Material:

PVC

Size (inches):

- 1/2 2
 3/4 2-1/2
 1 3
 1-1/4 4
 1-1/2

Seals:

- EPDM
 Fluoropolymer® (FPM)

Spring Material:

- 316SS
 PTFE/316SS
 Hastelloy®

End Connections:

- Socket (IPS)
 Threaded (FNPT)

IPEX Part Number:

SSE Series Spring Assisted Check Valves

Product Data Sheet

Valve Selection

SSE IPS Socket (inches)

Size	d	L	Z	H	E
1/2	0.84	0.89	2.01	3.78	2.13
3/4	1.05	1.00	2.13	4.13	2.48
1	1.315	1.13	2.34	4.61	2.83
1-1/4	1.66	1.26	2.83	5.35	3.35
1-1/2	1.9	1.38	3.03	5.79	3.94
2	2.375	1.50	3.84	6.85	4.65
2-1/2	2.875	1.75	4.8	8.31	6.18
3	3.5	1.89	5.98	9.76	6.85
4	4.5	2.26	6.61	11.14	8.35

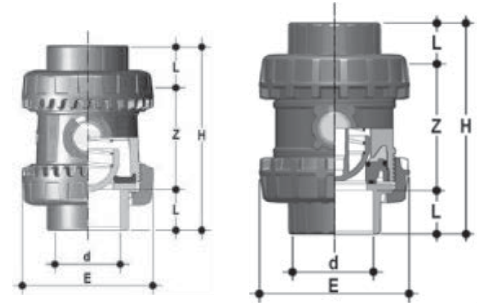

SSE NPT Female (inches)

Size	d	L	Z	H	E
1/2	1/2-NPT	0.70	2.14	3.54	2.13
3/4	3/4-NPT	0.71	2.24	3.66	2.48
1	1-NPT	0.89	2.55	4.33	2.83
1-1/4	1-1/4-NPT	0.99	3.02	5.00	3.35
1-1/2	1-1/2-NPT	0.97	3.21	5.16	3.94
2	2-NPT	1.17	4.01	6.34	4.65
2-1/2	2-1/2-NPT	1.31	5.69	8.31	6.18
3	3-NPT	1.4	6.97	9.76	6.85
4	4-NPT	1.48	8.18	11.14	8.35

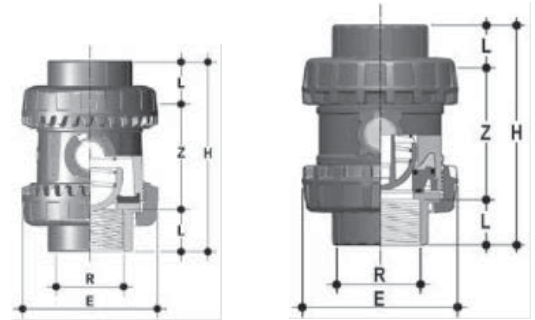

Weights

Approximate Weight (lbs)

Size	PVC	
	IPS Socket	FNPT Threaded
1/2	0.33	0.33
3/4	0.41	0.41
1	0.64	0.64
1-1/4	0.98	0.98
1-1/2	1.41	1.41
2	2.23	2.23
2-1/2	5.47	5.47
3	6.81	6.81
4	11.84	11.84

Minimum Back Pressure to Seal

Size	1/2	3/4	1	1-1/4	1-1/2	2	2-1/2	3	4
psi	1.16	1.16	1.16	1.16	1.16	1.16	1.16	1.16	1.16

Minimum Pressure to Open Spring

Size	1/2	3/4	1	1-1/4	1-1/2	2	2-1/2	3	4
psi	1.99	1.00	0.71	0.71	0.71	0.43	0.21	0.21	0.21

SSE Series Spring Assisted Check Valves

Product Data Sheet

Pressure

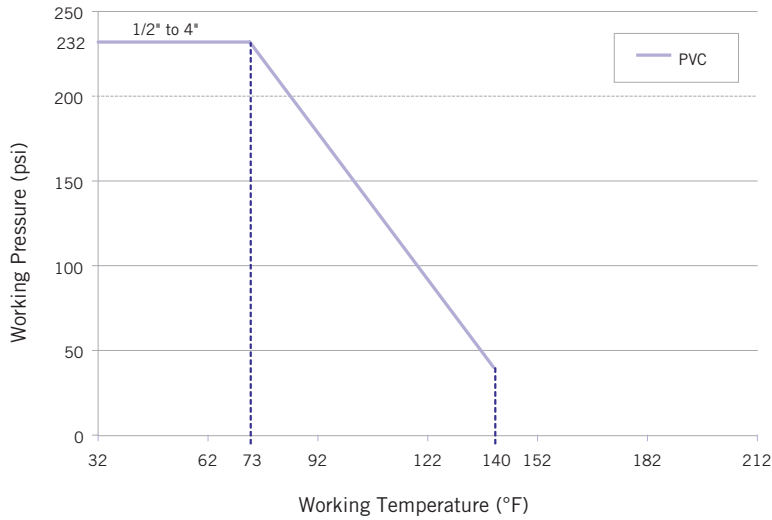

Flow Coefficients

The flow coefficient (C_v) represents the flow rate in gallons per minute (GPM) at 68°F for which there is a 1 psi pressure drop across the valve in the fully open position. These values are determined from an industry standard testing procedure which uses water as the flowing media (specific gravity of 1.0). To determine specific flow rate and pressure loss scenarios, one can use the following formula:

$$f = sg \times \left(\frac{Q}{C_v} \right)^2$$

Where,

- f is the pressure drop (friction loss) in psi,
- sg is the specific gravity of the fluid,
- Q is the flow rate in GPM,
- C_v is the flow coefficient.

Size	C_v
1/2	10.6
3/4	17.9
1	30.0
1-1/4	44.6
1-1/2	64.4
2	93.22
2-1/2	179.4
3	238.9
4	353.3

Pressure Loss Chart

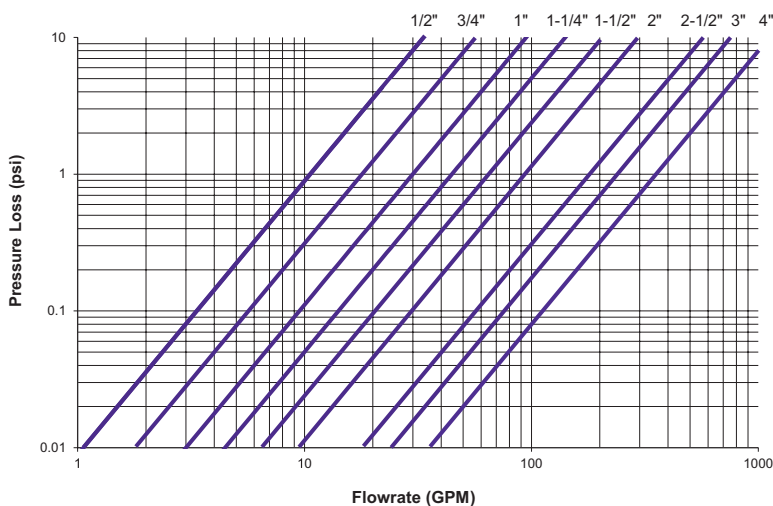

SSE Series Spring Assisted Check Valves

Product Data Sheet

Customize SSE EasyFit

It is often necessary to customize a valve by labelling or tagging it in order to mark, protect and identify it.



SSE EasyFit valves are therefore equipped with a plastic water-resistant module designed to meet this specific need. The module is composed of a transparent PVC service plug and a white circle tag holder, with IPEX branded on one side. The tag holder is embedded in the plug and can be easily removed to be used for self labelling on its blank side. Self labelling can be done in several ways, but we recommend designing and printing custom labels through the EasyFit Labelling System (LSE).



Please contact IPEX customer service for options and pricing on customization of SSE valves with LSE sets.

SSE Series Spring Assisted Check Valves

Product Data Sheet

Components

1/2" to 2"



#	Component	Material	Qty
1	Union Nut	PVC	2
2	End Connector	PVC	2
3	Socket Seal (O-ring)	EPDM, FPM	1
4	Body	PVC	1
5	Tag Holder	PVC	1
6	Transparent Service Plug	PVC	1
7	Contoured Ball	PVC	1
8	Spring	316SS, PTFE/316SS, Hastelloy	1
9	Contoured Ball Seal (O-ring)	EPDM, FPM	1

2-1/2" to 4"



#	Component	Material	Qty
1	Union Nut	PVC	2
2	End Connector	PVC	2
3	Socket Seal (O-ring)	EPDM, FPM	2
4	Body	PVC	1
5	Tag Holder	PVC	1
6	Transparent Service Plug	PVC	1
7	Contoured Ball	PVC	1
8	Packing Presser Ring	PVC	1
9	Contoured Ball Seal (O-ring)	EPDM, FPM	1
10	Support for Ball Seat	PVC	1
11	Radial Seal (O-ring)	EPDM, FPM	1
12	Spring	316SS, PTFE/316SS	1

SSE Series Spring Assisted Check Valves

Product Data Sheet

Installation Procedures



1. For socket and threaded style connections, remove the union nuts (part #1 on previous page) and slide them onto the pipe. **It is important to first check the pipe flow direction and corresponding valve orientation as installing the valve backward will prevent it from functioning as intended.**
2. Please refer to the appropriate connection style sub-section:
 - a. For socket style, solvent cement the end connectors (2) onto the pipe ends. For correct joining procedure, please refer to the section entitled, "Joining Methods – Solvent Cementing" in the IPEX Industrial Technical Manual Series, "Volume I: Vinyl Process Piping Systems". **Be sure to allow sufficient cure time before continuing with the valve installation.**
 - b. For threaded style, thread the end connectors (2) onto the pipe ends. For correct joining procedure, please refer to the section entitled, "Joining Methods – Threading" in the IPEX Industrial Technical Manual Series, "Volume I: Vinyl Process Piping Systems".



3. Ensure that the valve is in the correct orientation, and that the main seal safe blocked carrier and o-rings are properly fitted in the valve. A flow direction indicator is located on the side of the valve body. Carefully place the valve in the system between the two end connections.
4. Tighten both union nuts by hand. Hand tightening is typically sufficient to maintain a seal for the maximum working pressure. If additional tightening is required, use the EasyFit multifunctional handle tool to tighten the union nuts an additional 1/4 turn. The Easyfit torque wrench (available as an accessory for 1/2" – 2" valves) may also be used to complete the nut tightening in accordance to the torques indicated on instructions included; following this procedure will ensure the best installation.

Over-tightening may damage the threads on the valve body and/or the union nut, and may even cause the union nut to crack. It is recommended to use the EasyFit handle to prevent damage.



SSE Series Spring Assisted Check Valves

Product Data Sheet

Disassembly

1. If removing the valve from an operating system, isolate the valve from the rest of the system. **Be sure to depressurize and drain the isolated branch and valve before continuing.**
2. Loosen both union nuts (1) and drop the valve out of the line. If retaining the socket o-rings (3), take care that they are not lost when removing the valve from the line.
 - a. For 1/2" to 2" valves, remove the transparent service plug from the EasyFit multifunctional handle tool. Turn the handle over and seat on the top of the valve, ensuring the integrated gear teeth on the handle mesh with the union nut teeth. Turn clockwise to loosen.
 - b. For 2-1/2" to 4" valves, remove the EasyFit multifunctional tool from the bottom of the handle, turn it over and re-install it. Engage the tool with the outer ring profile of the union nut and loosen.
4. Line up the moldings on the handle with the slots in the main seal carrier. Loosen and remove the main seal carrier (10) by turning it in a counter-clockwise direction.
5. For 1/2" to 2" valves, remove the Radial Seal (11), Contoured Ball Seal (O-ring) (9), Packing-presser Ring (8), Contoured Ball (7), and the Spring (12)
6. For 2-1/2" to 4" valves, remove the Contoured Ball Seal (O-ring) (9), Contoured Ball (7), and the Spring (12).
7. The valve components can now be checked for problems and/or replaced.

Assembly

Note: Before assembling the valve components, it is advisable to lubricate the o-rings with a water soluble lubricant. **Be sure to consult the "IPEX Chemical Resistance Guide" and/or other trusted resources to determine specific lubricant-rubber compatibilities.**

1. For 1/2" to 2" valves, insert the Spring (8), Contoured Ball (7), and Contoured Ball Seal (O-ring) (9) in the valve body.
2. For 2-1/2" to 4" valves, insert the Spring (12), Contoured Ball (7), Packing Presser Ring (8), Contoured Ball Seal (O-ring) (9), and the Radial Seal (11) in the valve body.
3. For 2-1/2" to 4" valves, slightly hand-tighten the main seal carrier (10) into the valve body. Line up the moldings on the handle with the slots in the main seal carrier then tighten by turning in a clockwise direction.
4. Properly fit the socket o-rings (3) in their respective grooves.
5. Place the end connectors (2) into the union nuts (1), then thread onto the valve body taking care that the socket o-rings remain properly fitted in their grooves.
 - a. For 1/2" to 2" valves, remove the transparent service plug from the EasyFit multifunctional handle tool. Turn the handle over and seat on the top of the valve, ensuring the integrated gear teeth on the handle mesh with the union nut teeth. Turn counter-clockwise to tighten. The Easyfit torque wrench key can also be used to tighten the union nuts in accordance with the tightening torque values indicated on the included instructions.
 - b. For 2-1/2" to 4" valves, remove the EasyFit multifunctional tool from the bottom of the handle, turn it over and re-install it. Engage the tool with the outer ring profile of the union nut and tighten.



SSE Series Spring Assisted Check Valves

Product Data Sheet

Testing and Operating

The purpose of system testing is to assess the quality of all joints and fittings to ensure that they will withstand the design working pressure, plus a safety margin, without loss of pressure or fluid. Typically, the system will be tested and assessed in sub-sections as this allows for improved isolation and remediation of potential problems. With this in mind, the testing of a specific installed valve is achieved while carrying out a test of the overall system.

An onsite pressure test procedure is outlined in the IPEX Industrial Technical Manual Series, "Volume I: Vinyl Process Piping Systems" under the section entitled, "Testing". The use of this procedure should be sufficient to assess the quality of a valve installation. **In any test or operating condition, it is important to never exceed the pressure rating of the lowest rated appurtenance in the system.**

Important Points:

- Never test thermoplastic piping systems with compressed air or other gases including air-over-water boosters.
- When testing, do not exceed the rated maximum operating pressure of the valve.
- Avoid the rapid closure of valves to eliminate the possibility of water hammer which may cause damage to the pipeline or the valve.

Please contact IPEX customer service and technical support with regard to any concern not addressed in this data sheet or the technical manual.

SSE Series Spring Assisted Check Valves

About IPEX

About the IPEX Group of Companies

As leading suppliers of thermoplastic piping systems, the IPEX Group of Companies provides our customers with some of the world's largest and most comprehensive product lines. All IPEX products are backed by more than 50 years of experience. With state-of-the-art manufacturing facilities and distribution centers across North America, we have established a reputation for product innovation, quality, end-user focus and performance.

Markets served by IPEX group products are:

- Electrical systems
- Telecommunications and utility piping systems
- Industrial process piping systems
- Municipal pressure and gravity piping systems
- Plumbing and mechanical piping systems
- Electrofusion systems for gas and water
- Industrial, plumbing and electrical cements
- Irrigation systems
- PVC, CPVC, PP, PVDF, PE, ABS, and PEX pipe and fittings

Xirtec® is a registered trademark used under license.

This literature is published in good faith and is believed to be reliable. However, it does not represent and/or warrant in any manner the information and suggestions contained in this brochure. Data presented is the result of laboratory tests and field experience.

A policy of ongoing product improvement is maintained. This may result in modifications of features and/or specifications without notice.

ipexna.com
Toll Free: 866 473-9462

