

FK Series Butterfly Valves

Product Data Sheet



< STANDARDS >



ASTM D4101
ASTM D1784
ASTM D3222



ANSI B16.5



NSF 61

IPEX FK Series Butterfly Valves offer superior strength and chemical resistance in highly corrosive environments and process flow conditions. The special trapezoid shape of the liner and a serrated body cavity guarantee a bubble tight seal while keeping break-away torque at an absolute minimum. This versatile industrial valve features double self-lubricating seals, direct actuator mount capability, and the option of either a lever handle or mounted gear box. The FK lever handle includes the EasyFit labeling system for valve identification. A special integral stainless steel lug version provides for full bi-directional operation allowing disassembly of the downstream flange connection without weakening the integrity of the upstream connection to the pressurized line. FK Series Butterfly Valves are part of our complete systems of pipe, valves, and fittings, engineered and manufactured to our strict quality, performance, and dimensional standards.

VALVE AVAILABILITY

Body Material	Glass reinforced PP (GRPP)
Disc Material	CPVC, also offered in PP, PVC, ABS, and PVDF
Size Range	1-1/2" through 16"
Pressure	See Sample Specifications
Seals	EPDM or FKM
Body Style	Wafer or Lugged
Control Style	Lever Handle or Mounted Gear Box
End Connections	Flanged (ANSI 150)

FK Series Butterfly Valves

Product Data Sheet

Components

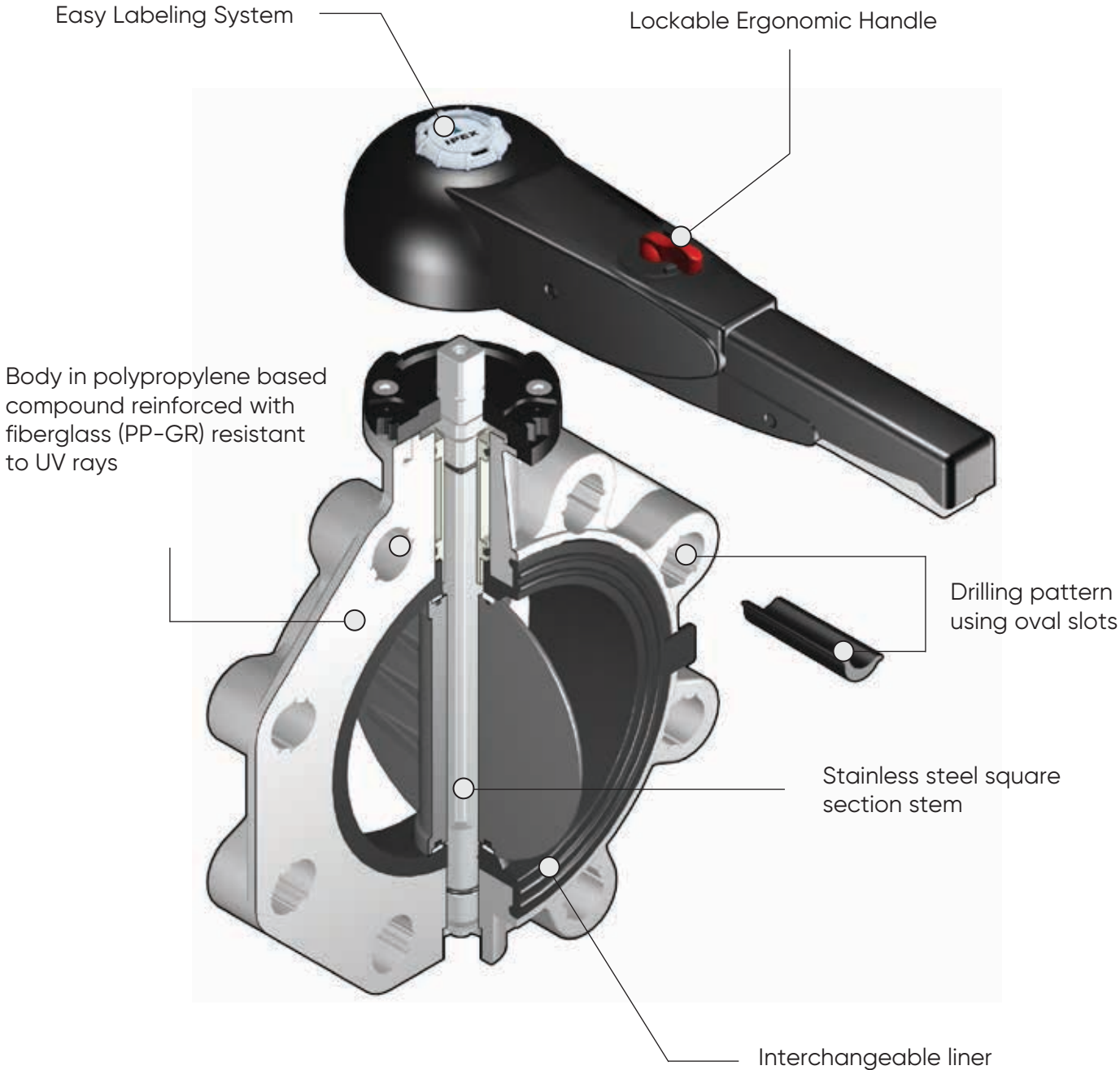

Sample Specifications

1.0 Butterfly Valves – FK

1.1 Material

- The valve body shall be made of glass reinforced polypropylene (GRPP) obtained from homopolymer polypropylene (PPH).
- The valve disc shall be made of Corzan® CPVC compound which shall meet or exceed the requirements of 23447 according to ASTM D1784.
- or The valve disc shall be made of stabilized PP homopolymer compound, also containing a RAL 7032 pigment, which shall meet or exceed the requirements of Type I Polypropylene according to ASTM D4101.
- or The valve disc shall be made of PVC compound which shall meet or exceed the requirements of cell classification 12454 according to ASTM D1784.
- or The valve disc shall be made of virgin, non-regrind PVDF compound which shall meet or exceed the requirements of Table 1 according to ASTM D3222.
- These compounds shall be listed with NSF to Standard 61 for potable water.
- The valve shaft shall be made of 316 stainless steel.

1.2 Seats

- The disc liner shall be made of EPDM.
- or The disc liner shall be made of FKM.

1.3 Seals

- The o-ring seals shall be made of EPDM.
- or The o-ring seals shall be made of FKM.

2.0 Connections

2.1 Flanged style

- The ANSI 150 flanged connections shall conform to the dimensional standard ANSI B16.5.

3.0 Design Features

- The valve shall be of either wafer or lugged design (specifier must select one).
- The lugged style shall feature permanently integrated stainless steel lugs.
- Manual control of the valve shall be achieved through the use of either a lever handle or mounted gear box (specifier must select one).
- The shaft shall have standard ISO square dimensions for direct mounting of actuators.
- The disc seat shall be a trapezoidal elastomeric liner and provide a bubble tight seal.
- The liner shall completely isolate the valve body from the process flow.
- The liner shall function as a flange gasket on both sides of the valve.
- The body cavity shall feature special channeling to prevent liner slippage and compression.
- The disc, seats, and seals shall be the only wetted parts.
- Teflon® seated o-ring seals shall prevent the stainless steel shaft from becoming wetted.
- The handle shall incorporate a transparent PVC plug and tag holder for valve identification.

3.1 Pressure Rating

CPVC Disc, Wafer Style

- 1-1/2" and 2" shall be rated at 232 psi at 73°F
- 2-1/2" to 10" shall be rated at 150 psi at 73°F
- 12" shall be rated at 120 psi at 73°F

PP Disc, Wafer Style

- 1-1/2" to 10" shall be rated at 150 psi at 73°F
- 12" shall be rated at 120 psi at 73°F
- 14" shall be rated at 100 psi at 73°F
- 16" shall be rated at 85 psi at 73°F

PVC Disc, Wafer Style

- 14" shall be rated at 100 psi at 73°F
- 16" shall be rated at 85 psi at 73°F

PVDF Disc, Wafer Style

- 1-1/2" and 2" shall be rated at 232 psi at 73°F
- 2-1/2" to 10" shall be rated at 150 psi at 73°F
- 12" shall be rated at 120 psi at 73°F

CPVC Disc, Lugged Style

- 2-1/2" to 8" shall be rated at 150 psi at 73°F
- 12" shall be rated at 85 psi at 73°F

PP Disc, Lugged Style

- 2-1/2" to 8" shall be rated at 150 psi at 73°F
- 10" and 12" shall be rated at 85 psi at 73°F

PVDF Disc, Lugged Style

- 2-1/2" to 8" shall be rated at 150 psi at 73°F
- 12" shall be rated at 85 psi at 73°F

3.2 Markings

- All valves shall be marked to indicate size, material designation, and manufacturers name or trade mark.

3.3 Color Coding

- All valve bodies shall be color-coded beige gray.
- CPVC valve discs shall be color-coded light gray
- PP valve discs shall be color-coded beige gray
- PVC valve discs shall be color-coded dark gray
- PVDF valve discs shall not be color-coded and be white in appearance

4.0 All valves shall be listed to NSF Standard 61 for potable water.

5.0 All valves shall be by IPEX or approved equal.

FK Series Butterfly Valves

Product Data Sheet

Valve Selection

Significant Number	IPEX Part Number	Body Material	Body Style	Liner Material	Size	Disc Material	Control Style	Pressure Rating @ 73°F
FKOM107C	353112	GRPP	Wafer	EPDM	1-1/2"	CPVC	Lever Handle	232
FKOM108C	353113				2"			
FKOM109C	353114				2-1/2"			150
FKOM110C	353115				3"			
FKOM111C	353116				4"			
FKOM112C	353117				5"			
FKOM113C	353118				6"			
FKOM114C	353119				8"			
FKOM207C	353137	GRPP	Wafer	FKM	1-1/2"	CPVC	Lever Handle	232
FKOM208C	353213				2"			
FKOM209C	353214				2-1/2"			150
FKOM210C	353216				3"			
FKOM211C	353218				4"			
FKOM212C	353224				5"			
FKOM213C	353225				6"			
FKOM214C	353226				8"			
FKOM109GC	254100	GRPP	Wafer	EPDM	2-1/2"	CPVC	Gearbox	150
FKOM110GC	254134				3"			
FKOM111GC	254135				4"			
FKOM112GC	254136				5"			
FKOM113GC	254137				6"			
FKOM114GC	254138				8"			
FKOM115GC	254128				10"	PVC		
FKOM116GC	254139				12"			120
FKOM117GV	253194				14"			100
FKOM118GV	253195				16"			85
FKOM209GC	254144	GRPP	Wafer	FKM	2-1/2"	CPVC	Gearbox	150
FKOM210GC	254155				3"			
FKOM211GC	254156				4"			
FKOM212GC	254157				5"			
FKOM213GC	254158				6"			
FKOM214GC	254159				8"			
FKOM215GC	254160				10"	PVC		
FKOM216GC	254161				12"			120
FKOM217GV	253196				14"			100
FKOM218GV	253197				16"			85

Significant Number

Code	FK	O	M	1	07	G	C
Position	1	2	3	4	5	6	7

Position	Code	Description
----------	------	-------------

1	Model	
	FK	Butterfly Valve

2	Connection		
	O	ANSI 150 Flange – Wafer	
	L	ANSI 150 Flange – 316 SS LUG	

3	Body Material	
	M	PP

4	Liner Material		
	1	EPDM	
	2	FKM	

5	Size	Imperial	DN
	07	1-1/2"	40 mm
	08	2"	50 mm
	09	2-1/2"	65 mm
	10	3"	80 mm
	11	4"	100 mm
	12	5"	125 mm
	13	6"	150 mm
	14	8"	200 mm
	15	10"	250 mm
	16	12"	300 mm
17	14"	350 mm	
18	16"	400 mm	

6	Control Style		
		Lever Handle	
	G	Gearbox	

7	Disc Material		
	C	CPVC	
	F	PVDF	
		PP	
	PVC		

FK Series Butterfly Valves

Product Data Sheet

Dimensions

Significant Number	IPEX Part Number	Body Material	Body Style	Liner Material	Size	Disc Material	Control Style	Pressure Rating @ 73°F
FKLM109C	353120	GRPP	ANSI 316 SS LUG	EPDM	2-1/2"	CPVC	Lever Handle	150
FKLM110C	353121				3"			
FKLM111C	353122				4"			
FKLM112C	353123				5"			
FKLM113C	353129				6"			
FKLM114C	353130				8"			
FKLM209C	353159	GRPP	ANSI 316 SS LUG	FKM	2-1/2"	CPVC	Lever Handle	150
FKLM210C	353167				3"			
FKLM211C	353168				4"			
FKLM212C	353169				5"			
FKLM213C	353170				6"			
FKLM214C	353171				8"			
FKLM109GC	254171	GRPP	ANSI 316 SS LUG	EPDM	2-1/2"	CPVC	Gearbox	150
FKLM110GC	254172				3"			
FKLM111GC	254173				4"			
FKLM112GC	254174				5"			
FKLM113GC	254175				6"			
FKLM114GC	254176				8"			
FKLM115GC	254142				10"			85
FKLM116GC	254143				12"			
FKLM209GC	254165	GRPP	ANSI 316 SS LUG	FKM	2-1/2"	CPVC	Gearbox	150
FKLM210GC	254166				3"			
FKLM211GC	254167				4"			
FKLM212GC	254168				5"			
FKLM213GC	254169				6"			
FKLM214GC	254170				8"			
FKLM215GC	254119				10"			85
FKLM216GC	254164				12"			

FK Series Butterfly Valves

Product Data Sheet

Pressure – Temperature Ratings

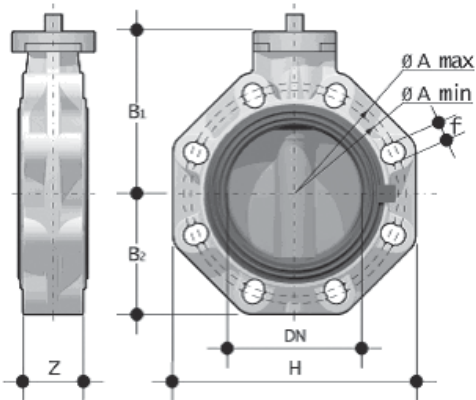

Free Stem – Dimension (inches)

Size	DN	Z	B ₁	B ₂	H	A _{min}	A _{max}	f	# holes
1-1/2	40	1.30	4.17	2.36	5.20	3.90	4.29	0.75	4
2	50	1.69	4.41	2.76	5.79	4.53	4.94	0.75	4
2-1/2	65	1.81	4.69	3.15	6.50	5.04	5.67	0.75	4
3	80	1.93	5.24	3.66	7.28	5.71	6.30	0.75	12*
4	100	2.20	5.79	4.21	8.31	6.50	7.48	0.75	8
5	125	2.52	6.57	4.72	9.45	8.03	8.46	0.91	8
6	150	2.76	7.09	5.28	10.55	9.06	9.53	0.91	8
8	200	2.80	8.94	6.34	12.72	11.02	11.73	0.91	8
10	250	4.49	9.76	8.27	15.94	13.19	14.25	1.00	12
12	300	4.49	12.01	9.65	18.70	15.35	17.01	1.14	12
14	350	5.08	12.99	11.02	20.87	18.74	18.74	1.12	12
16	400	6.65	13.78	12.05	23.39	21.26	21.26	1.12	16

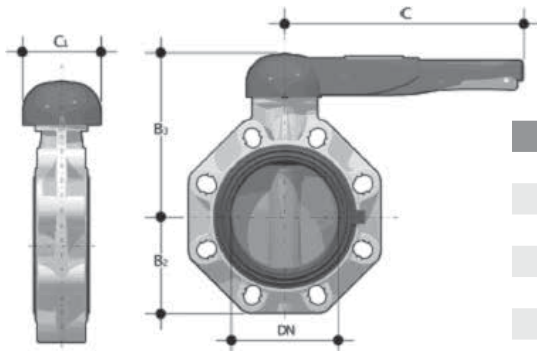

Lever Handle – Dimension (inches)

Size	DN	C1	C	B ₂	B ₃	# holes
1-1/2	40	3.94	6.89	2.36	5.39	4
2	50	3.94	6.89	2.76	5.63	4
2-1/2	65	4.33	10.71	3.15	6.46	4
3	80	4.33	10.71	3.66	7.01	12*
4	100	4.33	10.71	4.21	7.56	8
5	125	4.33	12.99	4.72	8.35	8
6	150	4.33	12.99	5.28	8.86	8
8	200	4.80	16.54	6.34	10.71	8

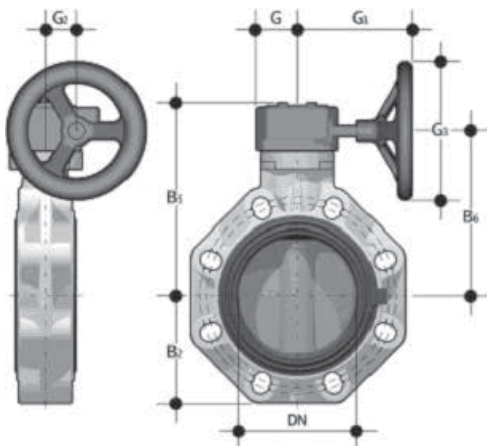

Gearbox Operated Butterfly Valve – Dimension (inches)

Size	DN	G ₂	G	G ₁	G ₃	B ₂	B ₃	B ₆	# holes
2-1/2	65	1.54	1.89	5.31	4.92	3.15	6.85	5.75	4
3	80	1.54	1.89	5.31	4.92	3.66	7.40	6.30	8
4	100	1.54	1.89	5.31	4.92	4.21	7.95	6.85	8
5	125	1.54	1.89	5.67	7.87	4.72	8.74	7.64	8
6	150	1.54	1.89	5.67	7.87	5.28	9.25	8.15	8
8	200	2.36	2.56	8.03	7.87	6.34	11.30	10.08	8
10	250	2.99	3.46	9.29	9.84	8.27	12.48	11.06	12
12	300	2.99	3.46	9.29	9.84	9.65	14.72	13.31	12
14	350	3.15	3.46	14.21	11.81	11.02	17.24	15.35	12
16	400	3.15	3.46	14.21	11.81	12.05	17.24	15.35	16

FK Series Butterfly Valves

Product Data Sheet

Customize FK EasyFit

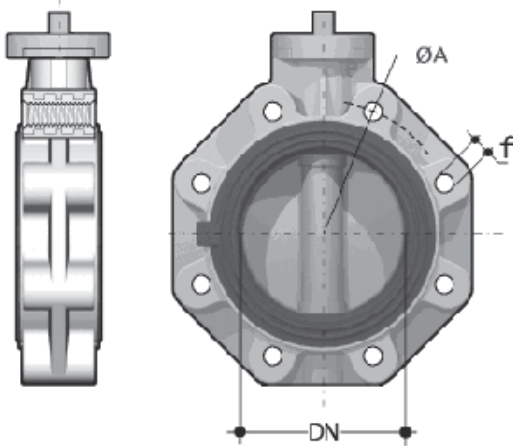

ANSI Lugged – Dimension (inches)

Size (in.)	DN	A	f	# holes
2-1/2	65	5.50	5/8 - UNC	4
3	80	6.00	5/8 - UNC	8
4	100	7.50	5/8 - UNC	8
5	125	8.50	3/4 - UNC	8
6	150	9.50	3/4 - UNC	8
8	200	11.75	3/4 - UNC	8
10	250	14.25	7/8 - UNC	12
12	300	17.00	7/8 - UNC	12

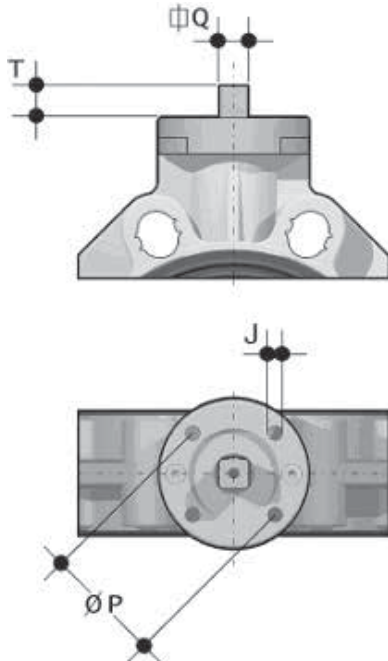

Mounting Pad for Actuation – Dimension (inches)

Size (in.)	ISO	J	P	T	Q
1-1/2	F05	0.28	1.97	0.47	0.43
2	F05	0.28	1.97	0.47	0.43
2-1/2	F05 / F07	0.28 / 0.35	1.97 / 2.76	0.47	0.43
3	F07	0.35	2.76	0.63	0.55
4	F07	0.35	2.76	0.63	0.55
5	F07	0.35	2.76	0.75	0.67
6	F07	0.35	2.76	0.75	0.67
8	F10	0.43	4.02	0.94	0.87
10	F10 / F12 / F14	0.43 / 0.51 / 0.67	4.02 / 4.92 / 5.51	1.14	1.06
12	F10 / F12 / F14	0.43 / 0.51 / 0.67	4.02 / 4.92 / 5.51	1.14	1.06
14	F12 / F14	0.55 / 0.71	4.92 / 5.51	1.14	1.06
16	F12 / F14	0.55 / 0.71	4.92 / 5.51	1.14	1.06

FK Series Butterfly Valves

Product Data Sheet

Weights

Size (in.)	Approximate Weight (lbs)		
	Valve	w/ Handle	w/ Gear Box
1-1/2	1.27	1.98	–
2	1.66	2.38	–
2-1/2	2.20	3.24	5.29
3	3.09	4.12	6.17
4	3.86	4.89	6.94
5	5.62	6.83	9.81
6	7.28	8.49	11.46
8	13.23	14.88	20.50
10	26.46	–	41.01
12	41.89	–	56.44
14	51.00	–	70.00
16	61.00	–	85.00

Pressure – Temperature Ratings

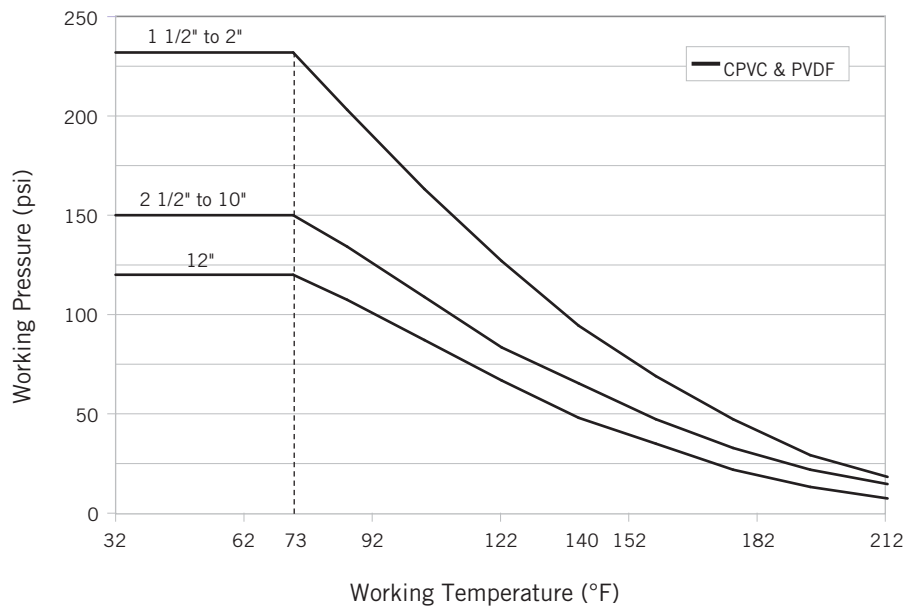

FK Series Butterfly Valves

Product Data Sheet

Pressure – Temperature Ratings

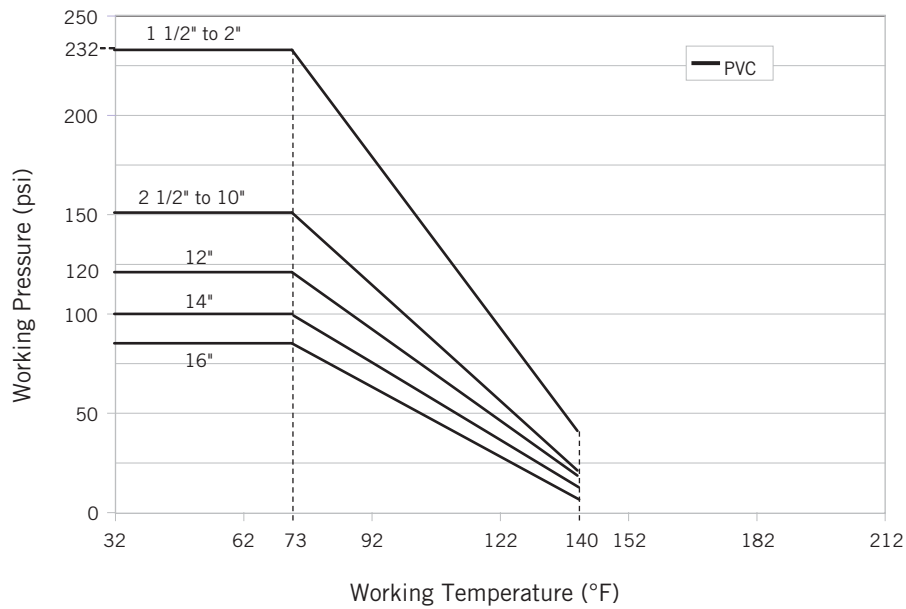
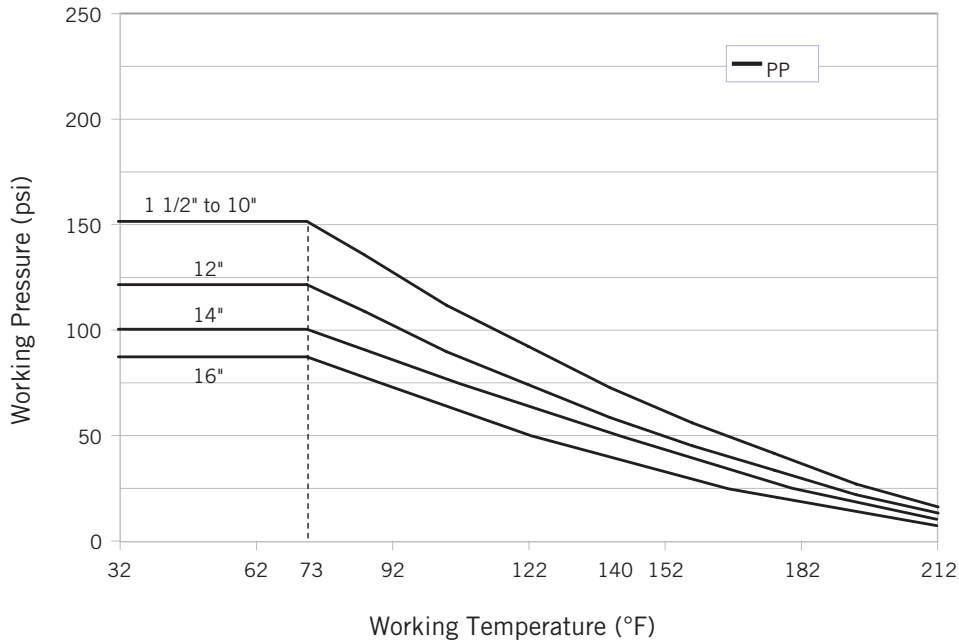

FK Series Butterfly Valves

Product Data Sheet

Flow Coefficients

The flow coefficient (C_v) represents the flow rate in gallons per minute (GPM) at 68°F for which there is a 1 psi pressure drop across the valve in the fully open position. These values are determined from an industry standard testing procedure which uses water as the flowing media (specific gravity of 1.0). To determine specific flow rate and pressure loss scenarios, one can use the following formula:

$$f = sg \times \left(\frac{Q}{C_v} \right)^2$$

Where,

- f is the pressure drop (friction loss) in psi,
- sg is the specific gravity of the fluid,
- Q is the flow rate in GPM,
- C_v is the flow coefficient.

Flow Coefficient Correction Factor

Use this chart to determine the appropriate flow coefficient correction factor depending on the amount of disc travel. As the valve cycles from fully open (100% travel) to fully closed (0% travel), the corresponding C_v value will decrease in accordance with the adjacent graph.

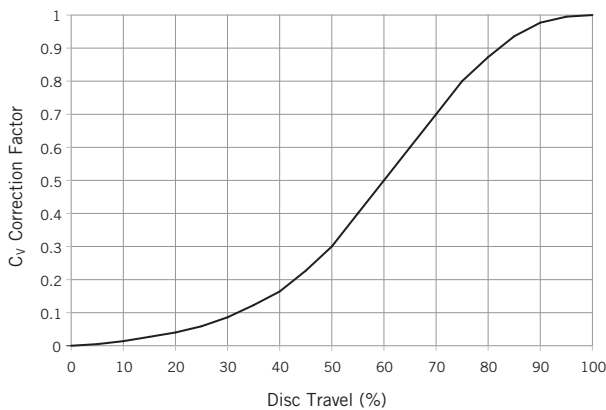

Size (in)	C_v
1-1/2	70
2	90
2-1/2	119
3	249
4	413
5	690
6	1309
8	2135
10	3724
12	5712
14	6587
16	8743

Pressure Loss Chart

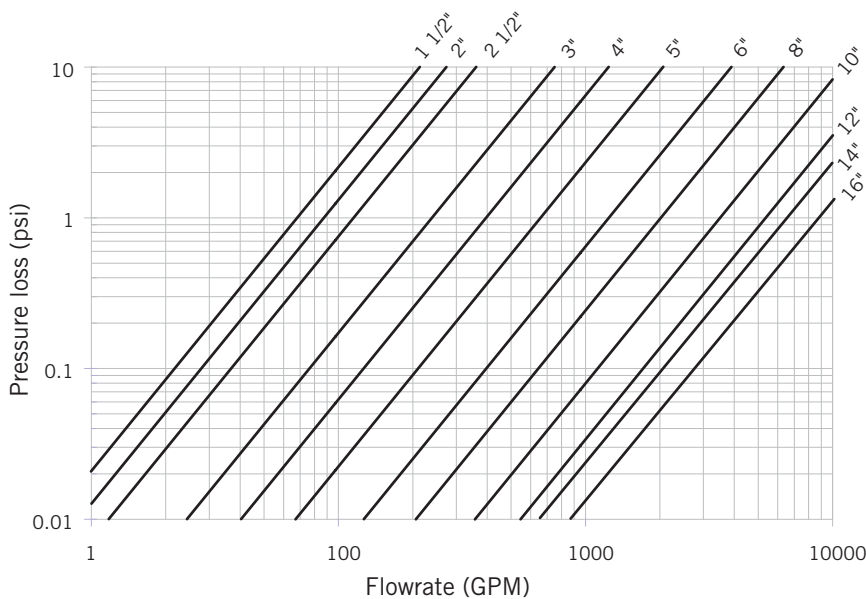

FK Series Butterfly Valves

Product Data Sheet

Customize FX EasyFit



- A** Transparent PVC Service Plug
- B** PVC Tag Holder
- C** EasyFit Multifunction Handle

It is often necessary to customize a valve by labelling or tagging it in order to mark, protect and identify it.



The FK is equipped with a specially designed water resistant module for the customization of the valve. The module is housed in the handle and is composed of a transparent PVC service plug and a white tag holder. The transparent plug can be easily removed to be used for self-labelling on its blank side. Self labelling can be done in several ways, but we recommend designing and printing custom labels through the EasyFit Labelling System (LSE).

FK Series Butterfly Valves

Product Data Sheet

Components

Size 1 1/2" – 2"

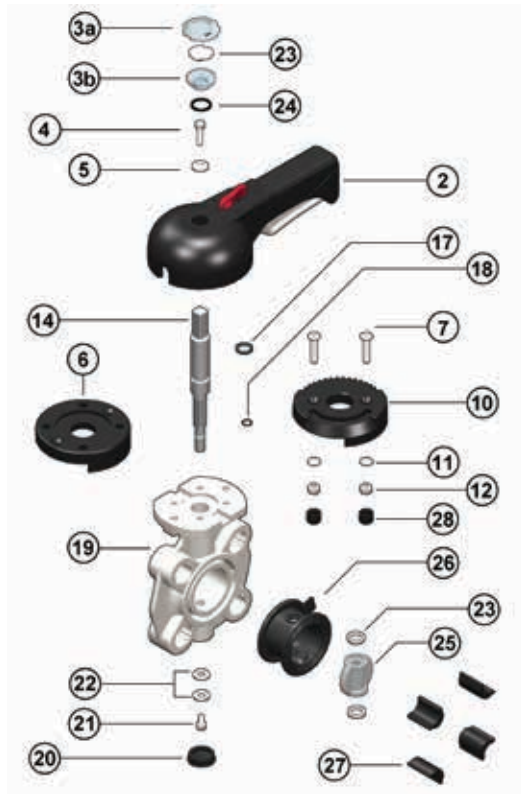

Size 2 1/2" – 8"

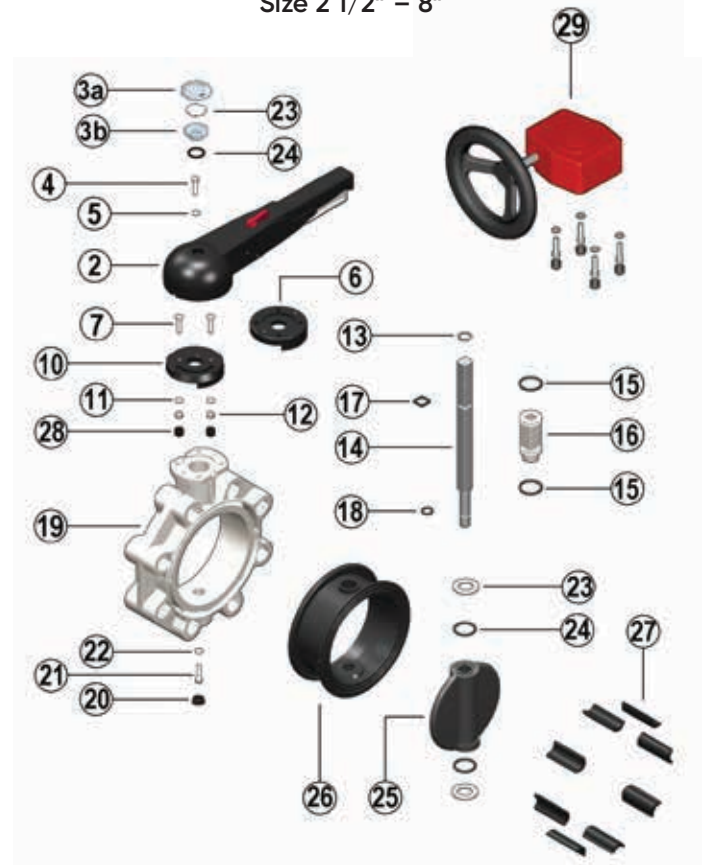

#	Component	Material	Qty
* 1	position indicator	PA	1
* 2	handle	PVC	1
* 3 a,b	transparent service plug	PVC	1
* 4	screw	SS	1
* 5	washer	SS	1
6	spacer pad	GRPP	1
7	screw	SS	2
8	screw	SS	2
9	ratchet	SS	1
10	pad	GRPP	1
11	washer	SS	2
12	nut	SS	2
13	retaining ring	SS	1
* 14	shaft	420 SS	1

* Spare parts available.

#	Component	Material	Qty
* 15	bushing o-ring	EPDM or FKM	2
16	bushing	Nylon	1
* 17	shaft o-ring	EPDM or FKM	1
* 18	shaft o-ring	EPDM or FKM	1
19	body	GRPP	1
20	cap	PE	1
21	screw	SS	1
22	washer	SS	1
* 23	anti-friction ring	PTFE	2
* 24	disc o-ring	EPDM or FKM	2
* 25	disc	CPVC / PP / PVC / ABS / PVDF	1
* 26	primary liner	EPDM or FKM	1
27	inserts	ABS	4 or 8
28	cap	PE	2
29	gearbox	Al, Steel	1

* Spare parts available.

FK Series Butterfly Valves

Product Data Sheet

Size 10" – 12"

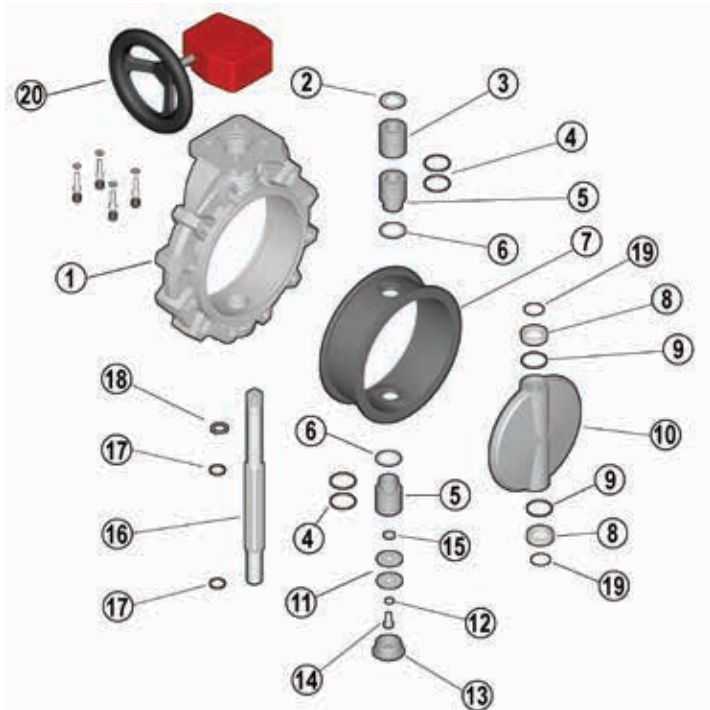

Size 14" – 16"



#	Component	Material	Qty
1	body	GRPP	1
2	washer	SS	1
3	bushing	PP	1
* 4	bushing o-ring	EPDM or FKM	4
5	bushing for o-ring	PP	2
6	washer	PTFE	2
* 7	primary liner	EPDM or FKM	1
* 8	anti-friction ring	PTFE	2
* 9	disc o-ring	EPDM or FKM	2
* 10	disc	CPVC / PP / PVC / PVDF	1
11	washer	SS	2
12	washer	SS	1
13	cap	PE	1
14	screw	SS	1
15	washer	SS	1
* 16	shaft	420 SS	1
* 17	shaft o-ring	EPDM or FKM	2
18	retaining ring	SS	1
19	o-ring	EPDM or FKM	2
20	gearbox	Al, Steel	1

* Spare parts available.

#	Component	Material	Qty
1	body	PP-GR	1
2	washer	Stainless Steel	1
3	bush	PP-H	1
4	bush o-ring	EPDM or FKM	6
5	bush	PP-H	1
6	washer	PP-H	2
7	liner (EPDM or FKM)	EPDM or FKM	1
8	anti-friction ring	PTFE	2
9	disk O-ring	EPDM or FKM	2
10	disk	PP-H	1
11	washer	Stainless Steel	1
12	washer	Stainless Steel	1
13	protection plug	PE	1
14	screw	Stainless Steel	1
16	stem	Stainless Steel	1
17	stem o-ring	EPDM or FKM	2
18	seeger ring	Stainless Steel	1
20	gearbox	Al, Steel	1
21	pin	Stainless Steel	21
22	washer	Stainless Steel	1
23	position indicator	PA	1

FK Series Butterfly Valves

Product Data Sheet

Installation Procedures

- For the lever handle style, attach the handle (part #2 on previous pages) to the valve body (19) using the supplied bolt (4) and washer (5). Affix the cap (3) over the bolt.
- For non-lugged style sizes 1-1/2" through 8", push the inserts (27) into the body holes according to the position chart below.
- Ensure that the length of the bolts is sufficient for the size of valve being installed. Due to the varying designs of plastic flanges, there is no recommended minimum length. However, a length that results in at least 5 exposed threads on each side should be sufficient.**
- Please refer to the appropriate application sub-section:
 - For typical inline installation, ensure that the disc is in the partially closed position then carefully insert the valve into the piping system between the two flanges. Insert the bolts, washers, and nuts (if necessary), then hand tighten. **Take care to properly line up the valve and flanges as any misalignment may cause leakage.**
 - For lugged version end of line installation, ensure that the disc is in the partially closed position then carefully position the valve on the flange. Insert the bolts, and washers, then hand tighten. **Take care to properly line up the valve and flange as any misalignment may cause leakage.**
- To avoid damage to the primary gasket, cycle the valve to the open position before tightening the bolts. For correct joining procedure, please refer to the section entitled, "Joining Methods – Flanging" in the IPEX Industrial Technical Manual Series, "Volume I: Vinyl Process Piping Systems". The bolts should be tightened in an even pattern to the nominal torque in the table below. These torque ratings are sufficient to maintain a watertight seal at the maximum rated operating pressure.

NOTE: If the process media is dirty or contains suspended particles, it is advisable to install the valve in an orientation in which the shaft is not vertical (see diagrams). Over time, particles may collect at the bottom of the valve posing a threat to the seal between the disc, liner, and shaft.

Size (in.)	ANSI 150 Insert Position	Nominal Bolt Torque (ft-lbs)
1-1/2	POS 1	7
2	–	9
2-1/2	POS 2	11
3	POS 2	13
4	POS 2	15
5	POS 2	26
6	POS 2	30
8	POS 2	41
10	–	52
12	–	52
14	–	55
16	–	55

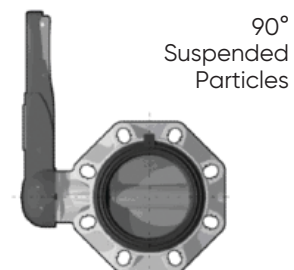
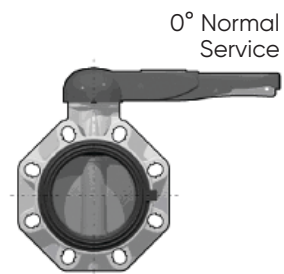
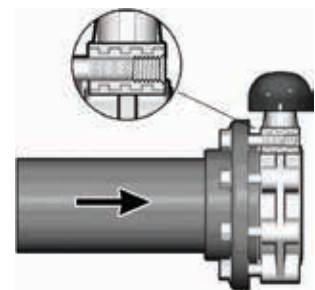
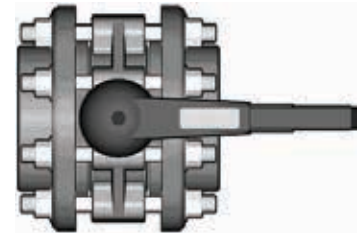
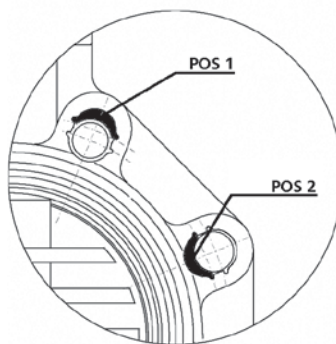

FK Series Butterfly Valves

Product Data Sheet

Testing and Operating

The purpose of system testing is to assess the quality of all joints and fittings to ensure that they will withstand the design working pressure, plus a safety margin, without loss of pressure or fluid. Typically, the system will be tested and assessed in sub-sections as this allows for improved isolation and remediation of potential problems. With this in mind, the testing of a specific installed valve is achieved while carrying out a test of the overall system.

An onsite pressure test procedure is outlined in the IPEX Industrial Technical Manual Series, "Volume I: Vinyl Process Piping Systems" under the section entitled, "Testing". The use of this procedure should be sufficient to assess the quality of a valve installation. **In any test or operating condition, it is important to never exceed the pressure rating of the lowest rated appurtenance in the system.**

Important points:

- Never test thermoplastic piping systems with compressed air or other gases including air-over-water boosters.
- When testing, do not exceed the rated maximum operating pressure of the valve.
- Avoid the rapid closure of valves to eliminate the possibility of water hammer which may cause damage to the pipeline or the valve.

The FK handle incorporates a locking mechanism that prevents unintentional rotation. When engaged, the spring-loaded handle release is locked and the valve cannot be cycled. A padlock can be installed through this portion of the handle as an additional safety precaution.

Please contact IPEX customer service and technical support with regard to any concern not addressed in this data sheet or the technical manual.

Sizes 1-1/2" to 2"



Sizes 2-1/2" to 8"

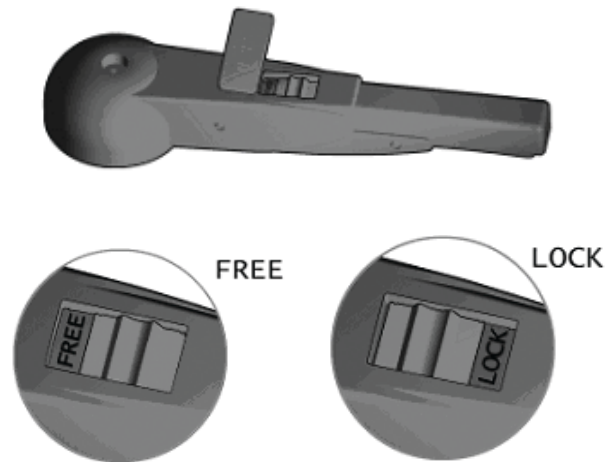

About IPEX by Aliaxis

As leading suppliers of thermoplastic piping systems, IPEX by Aliaxis provides our customers with some of the world's largest and most comprehensive product lines. All IPEX by Aliaxis products are backed by more than 50 years of experience. With state-of-the-art manufacturing facilities and distribution centers across North America, we have established a reputation for product innovation, quality, end-user focus and performance.

Markets served by IPEX by Aliaxis products are:

- Electrical systems
- Telecommunications and utility piping systems
- Industrial process piping systems
- Municipal pressure and gravity piping systems
- Plumbing and mechanical piping systems
- Electrofusion systems for gas and water
- Industrial, plumbing and electrical cements
- Irrigation systems
- PVC, CPVC, PP, PVDF, PE, ABS, and PEX pipe and fittings

This literature is published in good faith and is believed to be reliable. However, it does not represent and/or warrant in any manner the information and suggestions contained in this brochure. Data presented is the result of laboratory tests and field experience.

A policy of ongoing product improvement is maintained. This may result in modifications of features and/or specifications without notice.