

# CM Series Compact Diaphragm Valves

## Product Data Sheet



### < STANDARDS >



ASTM D1784  
ASTM D4101-86  
ASTM D3222  
ASTM D2466  
ASTM D2467  
ASTM F439



ISO 3609  
ISO 10931

IPEX CM Series Compact Diaphragm Valves have an efficient design and are ideal for OEMs. A variety of body and diaphragm materials plus the option of pneumatic actuation combine to make this valve the perfect choice in a wide range of applications. A standard position indicator and integrated mounting bushings complete the long list of features. CM Series Compact Diaphragm Valves are part of our complete systems of pipe, valves, and fittings, engineered and manufactured to our strict quality, performance, and dimensional standards.

### VALVE AVAILABILITY

Body Material:	PVC, CPVC, PP, PVDF
Size Range:	1/2", Metric 16mm & 20mm
Pressure:	90 psi
Diaphragm:	EPDM, Viton® (FPM), or PTFE (EPDM backed)
Control Style:	Manual Handwheel or Pneumatically Actuated
End Connections:	True Union (Socket) Socket (Metric) Spigot (Metric)

# CM Series Compact Diaphragm Valves

## Product Data Sheet

### Sample Specification

#### 1.0 Diaphragm Valves - CM

##### 1.1 Material

- The valve body, including end connectors and unions shall be made of PVC compound which shall meet or exceed the requirements of cell classification 12454 according to ASTM D1784.
- or The valve body, including end connectors and unions shall be made of Corzan® CPVC compound which shall meet or exceed the requirements of 23447 according to ASTM D1784.
- or The valve body, including end connectors and unions shall be made of stabilized PP homopolymer compound, also containing a RAL 7032 pigment, which shall meet or exceed the requirements of Type I Polypropylene according to ASTM D4101-86.
- or The valve body, including end connectors and unions shall be made of virgin, non-regrind PVDF compound which shall meet or exceed the requirements of Table 1 according to ASTM D3222.
- These compounds shall comply with standards that are equivalent to NSF Standard 61 for potable water.
- The valve bonnet assembly shall be made of reinforced polyamide (nylon).

##### 1.2 Diaphragm

- The diaphragm shall be made of EPDM which shall comply with standards that are equivalent to NSF Standard 61 for potable water.
- or The diaphragm shall be made of Viton® (FPM) which shall comply with standards that are equivalent to NSF Standard 61 for potable water.
- or The diaphragm shall be made of PTFE (backed with EPDM) which shall comply with standards that are equivalent to NSF Standard 61 for potable water.

- 1.3** All other wetted and non-wetted parts of the valves shall comply with standards that are equivalent to NSF Standard 61 for potable water.

#### 2.0 Connections

##### 2.1 Socket style

- The IPS socket PVC end connectors shall conform to the dimensional standards ASTM D2466 and ASTM D2467.
- or The IPS socket CPVC end connectors shall conform to the dimensional standard ASTM F439.
- or The Metric socket PP end connectors shall conform to the dimensional standard ISO 3609.
- or The Metric socket PVDF end connectors shall conform to the dimensional standard ISO 10931.

##### 2.2 Spigot style

- The Metric spigot PP end connectors shall conform to the dimensional standard ISO 3609.
- or The Metric spigot PVDF end connectors shall conform to the dimensional standard ISO 10931.

#### 3.0 Design Features

- All valves shall be weir-style for throttling applications.
- All bodies to be used with EPDM or Viton® diaphragms shall feature raised molded sealing rings (concentric).
- All bodies to be used with PTFE diaphragms shall be machined flat.
- All PTFE diaphragms shall feature a raised molded ring to combine sealing performance and longer life.
- All through bolts shall be made of 304 stainless steel.
- Bolts will thread directly into integrally molded brass inserts in the bonnet.
- All manual valves shall have a rising position indicator.
- Bodies of all sizes and materials shall have mounting brass inserts.

# CM Series Compact Diaphragm Valves

## Product Data Sheet

### 3.1 Actuators

- All actuators shall be made of reinforced polyamide (nylon).
- All actuators shall feature a smooth top (no nut holes) for cleanliness.
- The edge of the actuator membrane shall be inside of the actuator protective housing.
- All springs shall be cut from spring grade steel for maximum memory life and epoxy coated for maximum chemical resistance.
- The following accessories shall be available for all actuators: position indicator, stroke limiter, stroke limiter with position indicator, limit switch, limit switch box, 3-15 psi positioner, 4-20 mA positioner, solenoid pilot valve.

### 3.2 Pressure Rating

- All valves shall be rated at 90 psi at 73°F.

### 3.3 Markings

- All valves shall be marked to indicate size, material designation, and manufacturers name or trade mark.

### 3.4 Color Coding

- All PVC valves shall be color-coded dark gray.
- or All CPVC valves shall be color-coded light gray.
- or All PP valves shall be color-coded beige gray.
- or All PVDF valves shall not be color-coded and be white in appearance.

**4.0 All valves shall be Xirtec® 140, Corzan®, PP or PVDF by IPEX or approved equal.**

# CM Series Compact Diaphragm Valves

## Product Data Sheet

### Valve Selection

Valve Size (inches)	Body Material	Diaphragm Material	IPEX Part Number		Pressure Rating @ 73°F
			Manual True Union	Pneumatic True Union	
1/2	PVC	EPDM	054127	054151	90 psi
		Viton®	054129	054152	
		PTFE	054131	054153	
	CPVC	EPDM	054128	054154	
		Viton®	054130	054155	
		PTFE	054132	054156	

#### Body Material:

- PVC
- CPVC
- PP
- PVDF

#### Size:

- 1/2"
- 16mm
- 20mm

Valve Size (mm)	Body Material	Diaphragm Material	IPEX Part Number		Pressure Rating @ 73°F
			Manual Socket	Pneumatic Socket	
16	PP	EPDM	054133	054157	90 psi
		Viton®	054136	054160	
		PTFE	054139	054163	
	PVDF	EPDM	054142	054166	
		Viton®	054145	054169	
		PTFE	054148	054172	

#### Diaphragm:

- EPDM
- Viton® (FPM)
- PTFE

#### Control Style:

- Manual Handwheel
- Pneumatic (Normally Closed)

Valve Size (mm)	Body Material	Diaphragm Material	IPEX Part Number		Pressure Rating @ 73°F
			Manual Spigot	Pneumatic Spigot	
20	PP	EPDM	054134	054158	90 psi
		Viton®	054137	054161	
		PTFE	054140	054164	
	PVDF	EPDM	054143	054167	
		Viton®	054146	054170	
		PTFE	054149	054173	

#### End Connections:

- True Union (Socket)
- Socket
- Spigot

#### IPEX Part Number:

Valve Size (mm)	Body Material	Diaphragm Material	IPEX Part Number		Pressure Rating @ 73°F
			Manual True Union	Pneumatic True Union	
20	PP	EPDM	054135	054159	90 psi
		Viton®	054138	054162	
		PTFE	054141	054165	
	PVDF	EPDM	054144	054168	
		Viton®	054147	054171	
		PTFE	054150	054174	

# CM Series Compact Diaphragm Valves

## Product Data Sheet

### Dimensions – Manual Control

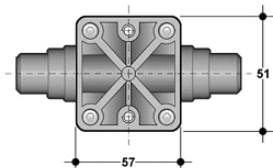
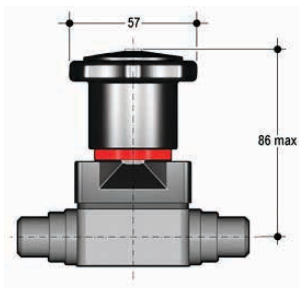
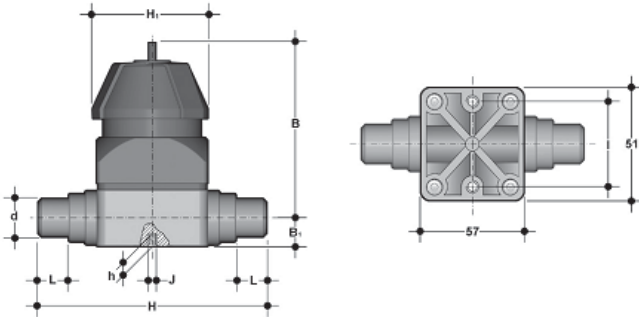
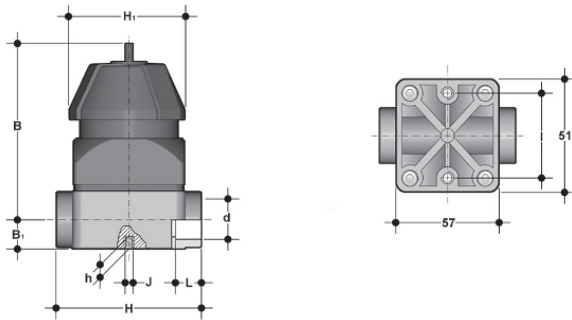
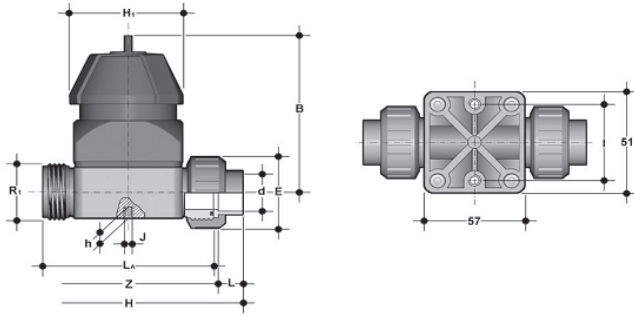

### True Union Connections

Dimension (inches)

Size	H	Z	L	LA	R <sub>1</sub>	E
1/2"	5.10	3.84	0.63	3.54	1"	1.61
20mm	5.10	3.84	0.63	3.54	1"	1.61

Dimension (inches)

Size	B	H <sub>1</sub>	h	J	I
1/2"	3.33	2.32	0.31	M5	1.38
20mm	3.33	2.32	0.31	M5	1.38

### Socket Connections

Dimension (inches)

Size	d	H	L	B <sub>1</sub>	B
16mm	0.68	2.95	0.55	0.59	3.33

Dimension (inches)

Size	H <sub>1</sub>	h	J	I
16mm	2.32	0.31	M5	1.38

### Spigot Connections

Dimension (inches)

Size	d	H	L	B <sub>1</sub>	B
20mm	0.84	4.88	0.67	0.59	3.33

Dimension (inches)

Size	H <sub>1</sub>	h	J	I
20mm	2.32	0.31	M5	1.38

### New Manual Bonnet

**Note:** As of July 2005, all new CM Manual valves are assembled with the bonnet shown on the side. The dimensions of the valve body and connections remain the same.

# CM Series Compact Diaphragm Valves

## Product Data Sheet

### Dimensions – Pneumatic Control

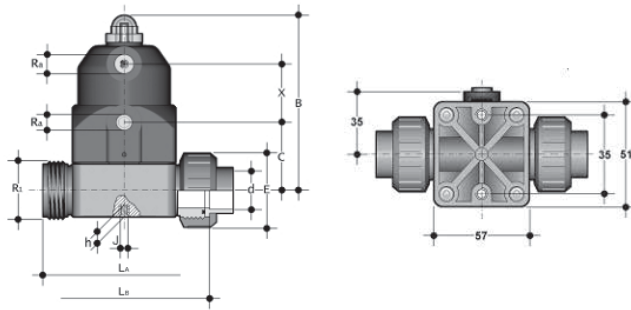

#### True Union Connections

Dimension (inches)

Size	d	L <sub>A</sub>	L <sub>B</sub>	R <sub>1</sub>	E	B
1/2"	0.84	3.54	3.78	1	1.61	3.86
20mm	0.84	3.54	3.78	1	1.61	3.86

Dimension (inches)

Size	C	X	R <sub>a</sub>	h	J
1/2"	1.50	1.34	1/8	0.31	M5
20mm	1.50	1.34	1/8	0.31	M5

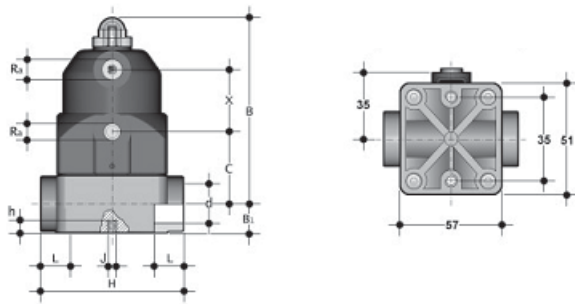

#### Socket Connections

Dimension (inches)

Size	d	H	L	B <sub>1</sub>	B
16mm	0.68	2.95	0.55	0.59	3.86

Dimension (inches)

Size	C	X	R <sub>a</sub>	h	J
16mm	1.50	1.34	1/8	0.31	M5

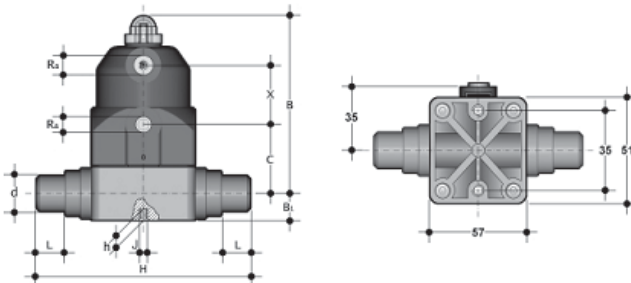

#### Spigot Connections

Dimension (inches)

Size	d	H	L	B <sub>1</sub>	B
20mm	0.84	4.88	0.63	0.49	3.86

Dimension (inches)

Size	C	X	R <sub>a</sub>	h	J
16mm	1.50	1.34	1/8	0.31	M5

# CM Series Compact Diaphragm Valves

## Product Data Sheet

### Weights

Approximate Weight (lbs) – Manual Control

Style	Size	PVC	CPVC	PP	PVDF
True	1/2"	0.63	0.64	-	-
Union	20mm	-	-	0.54	0.69
Socket	16mm	-	-	0.52	0.64
Spigot	20mm	-	-	0.58	0.75

Approximate Weight (lbs) – Pneumatic Control

Style	Size	PVC	CPVC	PP	PVDF
True	1/2"	0.69	0.71	-	-
Union	20mm	-	-	0.61	0.75
Socket	16mm	-	-	0.59	0.71
Spigot	20mm	-	-	0.65	0.82

### Pressure – Temperature Ratings

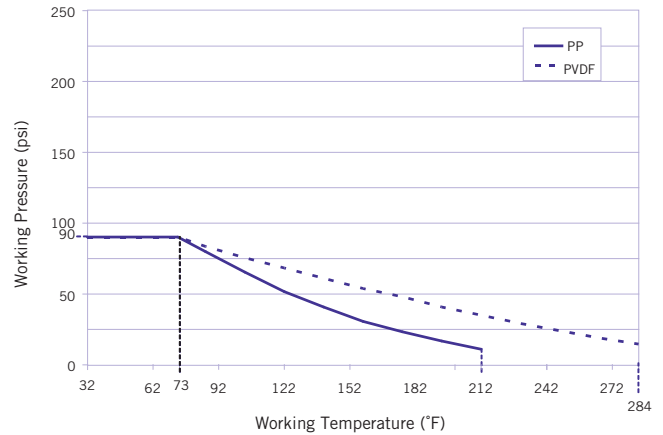
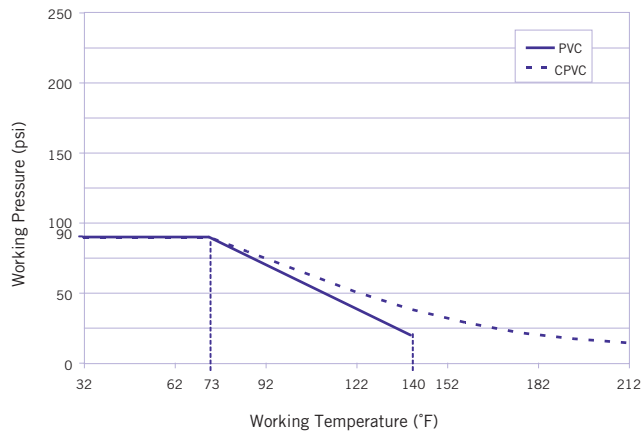

### Flow Coefficients

Size	C <sub>v</sub>
16mm	3.29
20mm	4.20
1/2"	4.20

### Pressure Loss Chart

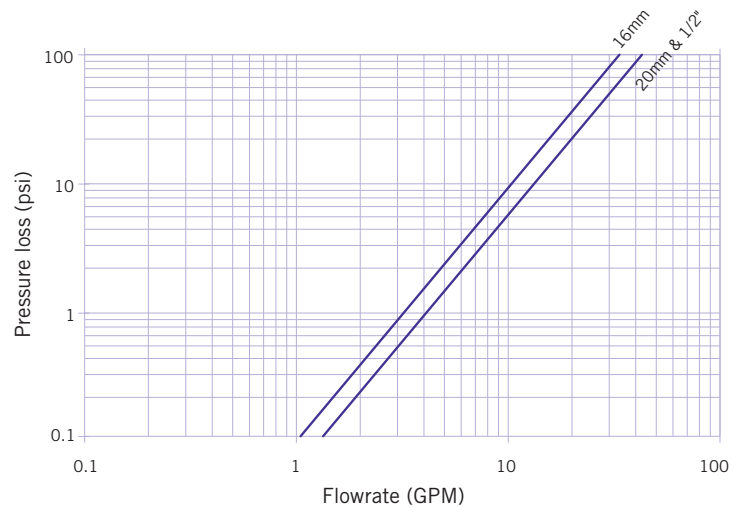

# CM Series Compact Diaphragm Valves

## Product Data Sheet

### Components

#### Manual Control

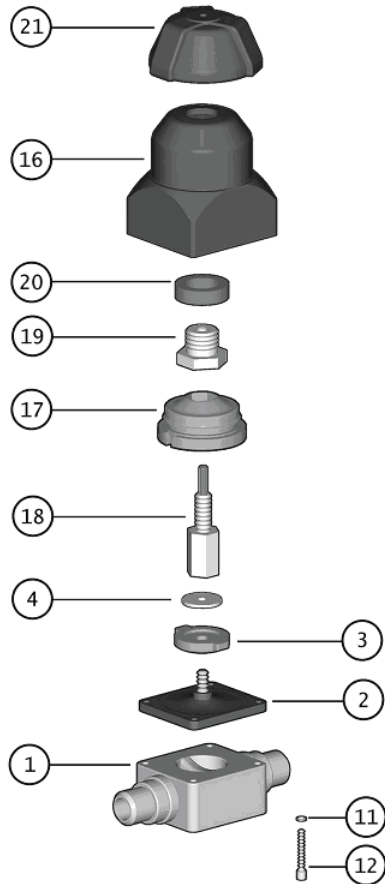

#### New Bonnet

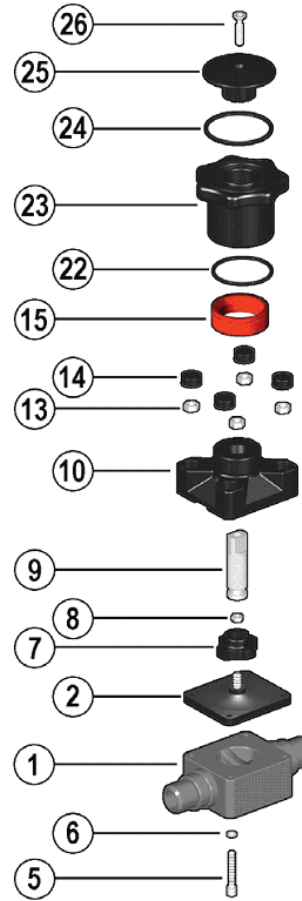

#	Component	Material	Qty
* 1	valve body	PVC / CPVC / PP / PVDF	1
2	diaphragm	EPDM / Viton® / PTFE	1
3	compressor	polyamide	1
4	washer	zinc plated steel	1
11	washer	SS	4
12	bolt	zinc plated steel	4
16	cover	polyamide	1
17	guide	polyamide	1
18	indicator – stem	brass	1
19	bushing	zinc plated steel	1
20	bonnet	brass	1
21	handwheel	GRPP	1

#	Component	Material	Qty
* 1	valve body	PVC / CPVC / PP / PVDF	1
2	diaphragm	EPDM / Viton® / PTFE	1
5	bolt	SS	4
6	washer	SS	4
7	compressor	GRPP	1
8	nut	SS	1
9	stem	SS	1
10	bonnet	GRPP	1
13	nut	SS	4
14	protective cap	POM	4
15	position indicator	PVDF	1
22	o-ring	NBR	1
23	handwheel	GRPP	1
24	o-ring	NBR	1
25	handwheel plate	GRPP	1
26	bolt	SS	1

\* Spare parts available. Contact IPEX for availability of spare components for True Union style valves.



# CM Series Compact Diaphragm Valves

## Product Data Sheet

### Pneumatic Control

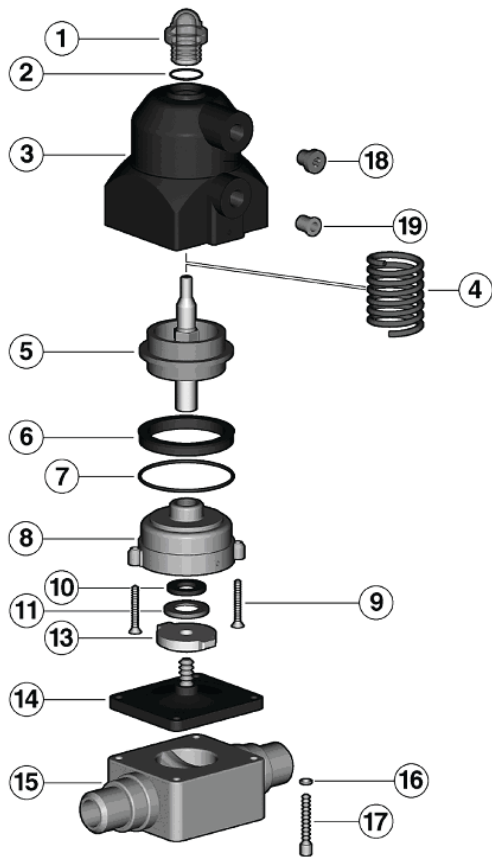

#	Component	Material	Qty
1	protective cap	PVC	1
2	o-ring	NBR	1
3	cover	polyamide	1
4	spring1	steel	1
5	stem – piston	SS - polyamide	1
6	gasket2	NBR	1
7	o-ring	NBR	1
8	guide	polyamide	1
9	bolt	zinc plated steel	2
10	gasket	NBR	1
11	washer	zinc plated steel	1
12	washer	zinc plated steel	1
13	compressor	polyamide	1
14	diaphragm	EPDM / Viton® / PTFE	1
* 15	valve body	PVC / CPVC / PP / PVDF	1
16	washer	zinc plate steel	4
17	bolt	SS	4

\* Spare parts available.  
 Contact IPEX for availability of spare components for True Union style valves.  
<sup>1</sup> for NC and NO versions only.  
<sup>2</sup> o-ring for DA version.

# CM Series Compact Diaphragm Valves

## Product Data Sheet

### Installation Procedures

1. The valve may be installed in any position or direction.
2. Please refer to the appropriate connection style sub-section:
  - a. For true union style, remove the union nuts and slide them onto the pipe.
    - i. For socket style, solvent cement the end connectors onto the pipe ends. For correct joining procedure, please refer to the section entitled, "Joining Methods – Solvent Cementing" in the IPEX Industrial Technical Manual Series, "Volume I: Vinyl Process Piping Systems". **Ensure that excess solvent does not run into the body of the valve. Be sure to allow sufficient cure time before continuing with the valve installation.**
    - ii. For threaded style, thread the end connectors onto the pipe ends. For correct joining procedure, please refer to the section entitled, "Joining Methods – Threading" in the IPEX Industrial Technical Manual Series, "Volume I: Vinyl Process Piping Systems".
    - iii. Ensure that the socket o-rings are properly fitted in their grooves then carefully place the valve in the system between the two end connections.
    - iv. Tighten both union nuts. Hand tightening is typically sufficient to maintain a seal for the maximum working pressure. Over-tightening may damage the threads on the valve body and/or the union nut, and may even cause the union nut to crack.
  - b. For socket style, solvent cement the pipe into the end connections of the valve. For correct joining procedure, please refer to the section entitled, "Joining Methods – Solvent Cementing" in the IPEX Industrial Technical Manual Series, "Volume I: Vinyl Process Piping Systems". **Ensure that excess solvent does not run into the body of the valve. Be sure to allow sufficient cure time before continuing with the valve installation.**
  - c. **For spigot style, solvent cement each pipe onto the ends of the valve body. Ensure that excess solvent does not run into the body of the valve.**
3. If anchoring is required, fix the valve to the supporting structure using the mounting holes on the bottom of the valve body.

# CM Series Compact Diaphragm Valves

## Product Data Sheet

### Disassembly

1. If removing the valve from an operating system, isolate the valve from the rest of the line. **Be sure to depressurize and drain the valve and isolated branch.**
2. If necessary, detach the valve from the support structure by disassembling the threaded connections on the bottom of the valve body.
3. Please refer to the appropriate connection style sub-section:
  - a. For true union connections, loosen both union nuts and drop the valve out of the line. If retaining the socket o-rings, take care that they are not lost when removing the valve from the line.
  - b. For socket style, cut the pipe on either side of the valve and remove from the line.
  - c. For spigot style, cut the pipe on either side of the valve and remove from the line.
4. Loosen and remove the bolts and washers from the bottom of the valve body. Removal of protective caps is necessary to access the nuts on the manual version.
5. Loosen and remove the diaphragm from the compressor assembly
6. Rotate the handwheel clockwise until the stem-compressor assembly is released.
7. The valve components can now be checked for problems and/or replaced.

**Note: It is not recommended to attempt to further disassemble the handwheel/bonnet assembly as it may cause irreversible damage to the components.**

### Assembly

**Note:** Before assembling the valve components, it is advisable to lubricate the o-rings with a water soluble lubricant. **Be sure to consult the "IPEX Chemical Resistance Guide" and/or other trusted resources to determine specific lubricant-rubber compatibilities.**

1. Insert the stem-compressor assembly into the bonnet and tighten by threading in a counterclockwise (left-hand thread) direction. Ensure that the guide tabs on the bonnet line up with the compressor grooves before cycling the handwheel to further retract the compressor.
2. Insert the diaphragm into the compressor and turn in a clockwise direction until sufficiently tight. Ensure that the tab lines up with the notched side of the bonnet then cycle the handwheel counterclockwise until the diaphragm is fully retracted.
3. Place the bonnet and diaphragm onto the valve body taking care to properly line up the sealing surfaces.
4. Insert the bolts and washers and tighten in an even (cross-like) pattern.
5. For the manual version, replace the protective caps on the nuts.

# CM Series Compact Diaphragm Valves

## Product Data Sheet

### Testing and Operating

The purpose of system testing is to assess the quality of all joints and fittings to ensure that they will withstand the design working pressure, plus a safety margin, without loss of pressure or fluid. Typically, the system will be tested and assessed in sub-sections as this allows for improved isolation and remediation of potential problems. With this in mind, the testing of a specific installed valve is achieved while carrying out a test of the overall system.

An onsite pressure test procedure is outlined in the IPEX Industrial Technical Manual Series, "Volume I: Vinyl Process Piping Systems" under the section entitled, "Testing". The use of this procedure should be sufficient to assess the quality of a valve installation. **In any test or operating condition, it is important to never exceed the pressure rating of the lowest rated appurtenance in the system.**

#### Important points:

- Never test thermoplastic piping systems with compressed air or other gases including air-over-water boosters.
- When testing, do not exceed the rated maximum operating pressure of the valve.
- Avoid the rapid closure of valves to eliminate the possibility of water hammer which may cause damage to the pipeline or the valve.

Please contact IPEX customer service and technical support with regard to any concern not addressed in this data sheet or the technical manual.

### About the IPEX Group of Companies

As leading suppliers of thermoplastic piping systems, the IPEX Group of Companies provides our customers with some of the world's largest and most comprehensive product lines. All IPEX products are backed by more than 50 years of experience. With state-of-the-art manufacturing facilities and distribution centers across North America, we have established a reputation for product innovation, quality, end-user focus and performance.

Markets served by IPEX group products are:

- Electrical systems
- Telecommunications and utility piping systems
- Industrial process piping systems
- Municipal pressure and gravity piping systems
- Plumbing and mechanical piping systems
- Electrofusion systems for gas and water
- Industrial, plumbing and electrical cements
- Irrigation systems
- PVC, CPVC, PP, PVDF, PE, ABS, and PEX pipe and fittings

---

This literature is published in good faith and is believed to be reliable. However, it does not represent and/or warrant in any manner the information and suggestions contained in this brochure. Data presented is the result of laboratory tests and field experience.

A policy of ongoing product improvement is maintained. This may result in modifications of features and/or specifications without notice.